



Heat exchanger with copper tubes and aluminium fins

Heat exchanger

WL



For the reheating of airflows in circular ducting

Circular hot water heat exchanger for the reheating of airflows, suitable for VAV terminal units TVR and mechanical self-powered CAV terminal units RN or VFC

- For hot water up to 150°C
- Copper tubes arranged in two rows, with aluminium fins
- Installation in horizontal or vertical ducts, independent of airflow direction
- Suitable for circular air ducts according to EN 1506 or EN 13180
- With lip seal and inspection access
- Maximum water-side operating pressure is 10 bar
- Casing air leakage according to EN 15727, class D



General information	2	Order code	6
Technical data	3	Dimensions and weight	7
Quick sizing	3	Installation details	8
Specification text	5	Nomenclature	9

General information

Application

Hot water heat exchanger for reheating the airflow in circular ducts
For VAV terminal units Type TVR and for CAV control units RN or VFC
For hot water up to 150°C
Construction not designed for and performance characteristics not applicable to cold water operation

Nominal sizes

100, 125, 160, 200, 250, 315, 400

Parts and characteristics

Ready-to-install heat exchanger
Copper tubes arranged in two rows
Lip seal
Inspection access
Tested for leakage

Construction features

- Rectangular casing
- Spigot with lip seal, for circular connecting ducts to EN 1506 or EN 13180
- Maximum water-side operating pressure is 10 bar
- Horizontal water connection
- Plain copper tube ends for water connection

Material and surfaces

- Casing made of galvanised sheet steel
- Copper pipes
- Aluminium fins

Standards and guidelines

- Casing air leakage according to EN 15727, class D

Maintenance

- Maintenance-free as construction and materials are not subject to wear



Technical data

Nominal sizes	100 – 400 mm
Volume flow rate range	10 – 750 l/s or 36 – 2700 m ³ /h
Thermal output	0.25 – 18 kW
Maximum hot water temperature	150 °C
Maximum water-side operating pressure	10 bar
Water-side differential pressure	0.3 – 12 kPa
Air-side static differential pressure	5 – 80 Pa

Quick sizing

Technical data of the heat exchanger Basic units: TVR, RN and VFC (TEST)

NS	q _v		Δ _{pv} [Pa]	PWW 50/40, t _e = 16 °C			
	[l/s]	[m ³ /h]		Φ [W]	t _a [°C]	sqm [l/h]	Dpw [kPa]
100	11	36	3	249	36.3	22	0.1
100	23	81	11	400	30.5	35	0.3
100	35	126	22	510	27.9	44	0.4
100	48	172	35	606	26.3	53	0.6
100	60	217	50	690	25.3	60	0.8
125	19	65	7	357	32.1	31	0.2
125	37	134	24	527	27.5	46	0.5
125	57	204	50	659	25.3	56	0.7
125	76	273	83	772	24.3	67	1
125	95	342	123	873	23.5	76	1.2
160	29	101	4	691	36.1	60	1.4
160	60	217	13	1,152	31.6	100	3.6
160	92	332	24	1,538	29.6	134	6.2
160	124	448	39	1,882	28.3	164	9
160	156	564	55	2,191	27.4	191	12.1
200	46	162	8	956	33.3	83	2.5
200	95	343	27	1,560	29.3	136	6.2
200	146	524	55	2,052	27.5	178	10.4
200	196	705	91	2,470	26.3	215	14.8
200	246	886	134	2,836	25.4	247	19.1
250	71	252	6	1,557	33.5	131	1.1
250	149	537	21	2,476	29.5	215	2.9
250	228	822	43	3,248	27.6	282	4.7
250	307	1,106	70	3,932	26.4	342	6.8
250	386	1,391	102	4,555	25.6	396	8.9
315	116	414	6	2,497	33.5	215	1.4
315	240	864	21	3,912	29.3	340	3.2
315	365	1,315	42	5,091	27.4	443	5.2
315	491	1,766	69	6,149	26.2	535	7.4
315	615	2,216	100	7,119	25.4	619	9.7
400	186	666	7	3,910	33.2	340	2.1
400	388	1,395	24	6,194	29	539	4.8
400	590	2,124	50	8,085	27.2	703	7.9
400	793	2,854	82	9,763	26	849	11.2



NS	q _v		Δ _{pv} [Pa]	PWW 50/40, te = 16 °C			
	[l/s]	[m ³ /h]		Φ [W]	t _a [°C]	sqm [l/h]	Dpw [kPa]
400	995	3,583	121	11,277	25.2	981	14.7

Φ: Thermal output

PWW: Pumped hot water heating system, flow temperature/return temperature

te: Inlet airflow temperature

ta: Outlet airflow temperature

qv: Volume flow rate

qm: Mass flow rate

Δpv: Water-side differential pressure

Δpst: Static differential pressure

Specification text

This specification text describes the general properties of the product. Texts for variants can be generated with our Easy Product Finder design programme.

Circular hot water heat exchangers for reheating the airflow in ventilation and air conditioning systems. Dimensions suitable for VAV terminal units TVR and CAV control units RN and VFC. Spigot with lip seal for ducts according to EN 1506 or EN 13180. Casing air leakage according to EN 15727, class D.

Materials and surfaces

- Casing made of galvanised sheet steel
- Copper pipes
- Aluminium fins

Technical data

- Volume flow rate range: 10 to 750 l/s or 36 to 2700 m³/h
- Thermal output: 0.25 – 18 kW
- Maximum water temperature: 150 °C
- Maximum water-side operating pressure: 10 bar
- Water-side differential pressure: 0.3 – 12 kPa
- Static differential pressure: 5 to 80 Pa

Sizing data

- q_v (m³/h)
- t_e [°C]
- PWW [°C]
- Φ [kW]



Order code

WL / 160
| |
1 2

1 Type

WL Hot water heat exchanger for volumetric flow controllers
TVE, TVR and KVS controllers RN and VFC

2 Nominal size [mm]

100, 125, 160, 200, 250, 315, 400

Order example: WL/160

Type	WL – Hot water heat exchanger
Nominal size [mm]	160

Dimensions and weight

WL, dimensions

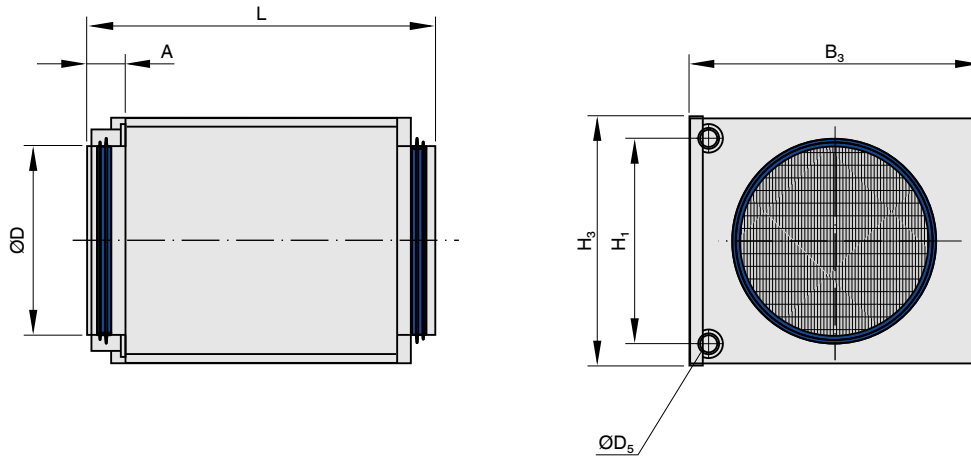

Dimensions and weights of the heat exchanger

NS	ØD	L	B3	H3	H1	A	ØD5	~ m [kg]
100	99	336	251	188	137	30	10	4.0
125	124	346	251	188	137	35	10	4.0
160	159	386	326	263	212	40	10	6.0
200	199	386	326	263	212	40	10	6.0
250	249	386	411	338	250	40	22	8.0
315	314	386	486	413	325	40	22	10.0
400	399	386	557	489	400	55	22	14.0

Diameter and material thickness of the connection pipes

NS	Dimensions
100	Cu Ø 10 × 0.8
125	Cu Ø 10 × 0.8
160	Cu Ø 10 × 0.8
200	Cu Ø 10 × 0.8
250	Cu Ø 22 × 1
315	Cu Ø 22 × 1
400	Cu Ø 22 × 1



Installation details

- Installation in horizontal or vertical ducts independent of airflow direction
- Capacity control and supply connections to be provided by others
- Vents and drainage by others

Nomenclature

L [mm]; [in]

Length of unit including connecting spigot

L₁ [mm]; [in]

Length of casing or acoustic cladding

B [mm]; [in]

Duct width

B₁ [mm]; [in]

Screw hole pitch of flange (horizontal)

B₂ [mm]; [in]

Overall dimension of flange (width)

B₃ [mm]

Unit width

H [mm]; [in]

Duct height

H₁ [mm]; [in]

Screw hole pitch of flange (vertical)

H₂ [mm]; [in]

Overall dimension of flange (height)

H₃ [mm]

Unit height

R ["]

Diameter of connecting threaded pipes

m [kg]; [lb]

Unit weight including the minimum required attachments (control component)

q_v [m³/h]; [l/s]; [CFM]

Volume flow rate

q_m [kg/h]

Mass flow rate

Δp_v [kPa]

Water-side differential pressure

Δp_{st} [Pa]; [inWg]

Static differential pressure

ØD₄ [mm]

Inside diameter of the screw holes of flanges

Φ [kW]

Thermal output

PWW [°C]

Hot water heating system, flow temperature/return temperature

t_e [°C]

Inlet airflow temperature

t_a [°C]

Outlet airflow temperature

Lengths

All lengths are given in millimetres [mm] unless stated otherwise.