

RFD-Sirius, cross bar

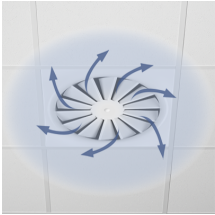

Horizontal swirling air discharge



Circular diffuser face



RFD-SIRIUS, integral measuring tubes



RFD-SIRIUS, volume flow controller

# Ceiling swirl diffusers

## RFD-SIRIUS

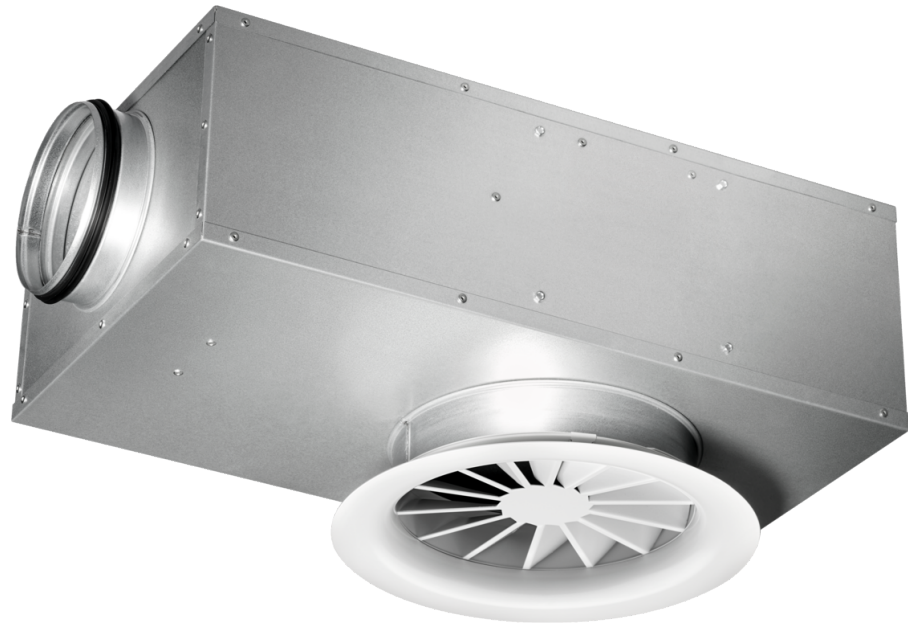

### RFD-SIRIUS is an air terminal device combined with a VAV terminal unit

RFD-SIRIUS is used in ventilation and air conditioning systems for the demand-based volume flow control and as an air terminal device.

- Nominal sizes RFD: 160, 200, 250, 315 and 400
- Nominal sizes SIRIUS: 125, 160, 200 and 250
- Volume flow rate range: 4.7 to 171.3 l/s or 17 to 617 m<sup>3</sup>/h
- For supply air
- Flush ceiling installation, with discharge nozzle also suspended installation
- Control input signal via MP bus, LonWorks FTT-10A, Modbus RTU, or analogue signal
- Integral noise insulation element
- High induction results in a rapid reduction of the temperature difference and airflow velocity
- Ideal for comfort zones

Optional equipment and accessories

- Exposed diffuser face available in RAL CLASSIC colours

General information	2	Order code	8
Function	3	Variants	9
Technical data	5	Dimensions	10
Quick sizing	5	Product details	13
Specification text	7	Explanation	15

## General information

### Application

- For supplying air to comfort zones in cases where the supply air flow rate is to be controlled
- The variant with discharge nozzle allows for suspended installation
- The efficient swirl creates high induction levels, thereby rapidly reducing the temperature difference and airflow velocity
- Closed-loop volume flow control using an external power supply
- Differential pressure measurement with integral measuring tubes

### Special characteristics

- RFD-SIRIUS combines the functions of a volume flow controller, sound attenuator, plenum box and air terminal device in one unit.
- Low sound power level, ideal for comfort zones
- For all types of ceiling systems, also suitable for freely suspended installation
- Differential pressure measurement with integral measuring tubes

### Nominal sizes

- RFD: 160, 200, 250, 315 und 400
- SIRIUS: 125, 160, 200 and 250

### Variants

#### Diffuser face

- RFD-R: Circular diffuser face
- RFD-Q: Square diffuser face
- RFD-\*-D: Diffuser face with discharge nozzle

#### Control components

- BC0
- BL0
- BM0
- BM0-J6

For information on control components see Type Compact controllers.

### Parts and characteristics

- Circular or square diffuser face
- Diffuser face with radially arranged fixed air control blades
- Control component can be moved back and forth

### Parts and characteristics

- Circular or square diffuser face
- Diffuser face with radially arranged fixed air control blades
- Control component can be moved back and forth

### Attachments

Variable volume flow control with electronic Compact controller to switch an external control signal and an actual value signal for integration into the central BMS.

- Supply voltage 24 V AC/DC
- The signal interface depends on the selected control component variant
- Variable air or constant air volume flow control
- The flow rate is measured according to the dynamic measurement principle
- Volume flow rate control range: approx. 10 – 100 % of the nominal volume flow rate

#### Deviation from the operating range:

- 10 – 20% of the nominal volume flow rate: +/- 25%
- 20 – 40% of the nominal volume flow rate: +/- 10%
- 40 – 100% of the nominal volume flow rate: +/- 4%

Electrical connection with cable or plug, depending on the selected control component variant.

### Material and surfaces

- Diffuser face and plenum box made of galvanised sheet steel
- Measuring unit made of aluminium
- Exposed parts of the diffuser face powder-coated RAL 9010, pure white
- P1: Powder-coated, RAL CLASSIC colour
- Noise insulating fleece on the controller cage

### Technical data

- RFD nominal sizes: 160, 200, 250, 315, 400 mm
- SIRIUS nominal sizes: 125, 160, 200, 250 mm
- Volume flow rate: 4.7 – 171.4 l/s or 17 – 617 m<sup>3</sup> /h
- Supply air to room air temperature difference: –12 to +10 K

### Maintenance

- Low maintenance as construction and materials are not subject to wear and tear
- Inspection and cleaning according to VDI 6022

## Function

### Functional description

RFD-SIRIUS combines the functions of a volume flow controller, sound attenuator, plenum box and air terminal device in one unit. To determine the current actual volume flow rate, the differential pressure is measured using the integrated measuring tubes and

transmitted to the controller. Depending on the desired setpoint value, the volume flow control unit is adjusted with an integrated linear actuator. The construction of the diffuser ensures that sound is effectively absorbed, which results in low sound power levels.

### Schematic illustration of RFD-SIRIUS

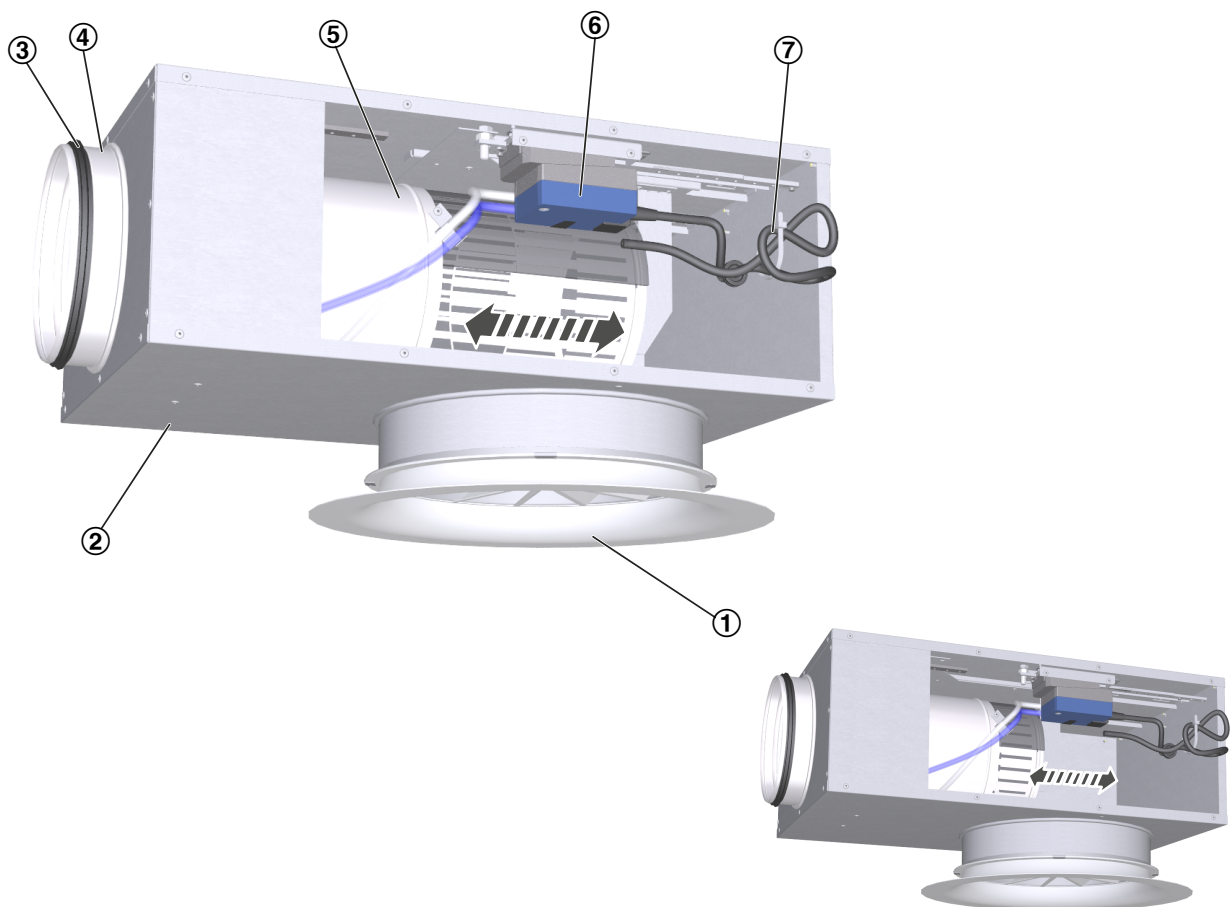

- 1 Diffuser face type RFD
- 2 SIRIUS plenum box
- 3 Lip seal
- 4 Spigot
- 5 Controller cage
- 6 Control component
- 7 Electrical connecting cable

Horizontal omnidirectional flow



### Technical data

Nominal sizes RFD	160, 200, 250, 315, 400 mm
Nominal sizes SIRIUS	125, 160, 200, 250 mm
Volume flow rate	4.7 – 171.4 l/s or 17 – 617 m³/h
Supply air to room air temperature difference	-12 to +10 K

### Quick sizing

Quick sizing tables provide a good overview of the volume flow rates and corresponding sound power levels and differential pressures.

The minimum volume flow rates apply to a supply air temperature difference of -6 K.

The maximum volume flow rates apply to a sound power level of approx. 50 dB (A).

#### Sound power level [dB (A)] – RFD-SIRIUS

Combination	qv [l/s]	qv [m³/h]	Δp <sub>t</sub> [Pa]			
			50	100	200	300
RFD-160 SIRIUS 125	5	17	≤15	≤15	≤15	15
	14	52	25	27	29	30
	24	87	32	34	36	37
	34	123	36	38	40	42
RFD-200 SIRIUS 125	7	25	15	17	20	22
	22	80	25	28	31	33
	37	134	30	33	36	38
	53	189	33	36	39	41
RFD-200 SIRIUS 160	7	25	≤15	15	18	20
	25	90	25	29	32	33
	43	155	31	34	37	39
	61	219	–	38	41	43
RFD-250 SIRIUS 160	10	37	≤15	15	18	20
	34	121	23	26	29	31
	57	204	27	31	34	35
	80	288	31	34	37	39
RFD-250 SIRIUS 200	10	37	20	24	28	30
	39	141	28	32	36	38
	68	245	31	35	39	41
	97	349	–	37	41	43
RFD-315 SIRIUS 200	19	68	27	31	36	39
	50	180	29	34	39	42
	81	292	31	35	40	43
	112	404	32	36	41	44
RFD-315 SIRIUS 250	19	68	18	22	26	28
	52	187	26	30	34	36
	85	305	30	34	38	40
	118	424	32	36	40	42
RFD-400 SIRIUS 250	27	96	24	29	33	36
	73	263	29	33	38	40
	119	429	31	35	40	42
	166	596	32	36	41	44

#### Sound power level [dB (A)] – RFD-SIRIUS-D



Combination	qv [l/s]	qv [m³/h]	$\Delta p_i$ [Pa]			
			50	100	200	300
RFD-D-160 SIRIUS 125	6	23	22	24	27	28
	20	72	29	31	34	35
	34	122	32	35	37	38
	48	171	34	37	39	40
RFD-D-200 SIRIUS 125	9	32	15	18	21	23
	27	97	23	27	30	32
	45	161	27	31	34	36
	63	226	30	33	36	38
RFD-D-200 SIRIUS 160	9	32	20	23	26	28
	34	121	28	31	34	36
	58	210	32	35	37	39
	83	299	34	37	40	41
RFD-D-250 SIRIUS 160	14	50	≤15	15	19	22
	37	134	19	24	28	31
	61	218	24	28	33	35
	84	303	27	31	36	38
RFD-D-250 SIRIUS 200	14	50	20	25	30	32
	47	170	27	32	37	40
	81	290	30	35	40	43
	114	410	32	37	42	45
RFD-D-315 SIRIUS 200	25	90	23	29	35	39
	59	214	26	32	38	42
	94	339	27	34	40	44
	129	463	28	35	41	45
RFD-D-315 SIRIUS 250	25	90	22	26	29	31
	68	245	28	31	35	37
	111	401	30	34	37	39
	154	556	32	36	39	41
RFD-D-400 SIRIUS 250	36	128	25	28	31	34
	81	291	29	32	34	38
	126	454	31	34	37	40
	171	617	32	36	38	41

## Specification text

This specification text describes the general characteristics of the product. Texts for variants can be generated with our Easy Product Finder design programme.

RFD-SIRIUS is an air terminal device combined with a VAV terminal unit.

The ceiling diffuser with a square or circular diffuser face is preferably used as a supply air diffuser for comfort zones.

The fixed air control blades allow for horizontal swirling supply air discharge creating high induction levels.

The diffuser is suitable for installation into all types of suspended ceilings.

The diffuser is fixed with a central fixing screw to the cross bar (no tools required); the cross bar is inserted into the SIRIUS plenum box (no tools required) and held in place with magnets. The SIRIUS plenum box is fitted with two spigots, one for connection to the ductwork and another one for connection of the diffuser face.

The SIRIUS plenum box contains two cylinders, one fitted inside the other; one of the cylinders is perforated.

The perforated cylinder is moved along a toothed bar upon control input from the volume flow controller, and the free area changes as a consequence.

A fleece covering the perforated cylinder acts as an equalising element.

This special construction feature allows for omitting any additional sound attenuator.

### Special features

- RFD-SIRIUS combines the functions of a volume flow controller, sound attenuator, plenum box and air terminal device in one unit.
- Low sound power level, ideal for comfort zones
- For all types of ceiling systems, also suitable for freely suspended installation
- Differential pressure measurement with integral measuring tubes

### Materials and surfaces

- Diffuser face and plenum box made of galvanised sheet steel
- Measuring unit made of aluminium

- Exposed parts of the diffuser face powder-coated RAL 9010, pure white
- P1: Powder-coated, RAL CLASSIC colour
- Noise insulating fleece on the controller cage

### Attachments

Variable volume flow control with electronic compact controller for the connection of a reference variable and feedback of an actual value signal for integration into the MCE/BACS.

- Supply voltage 24 V AC/DC
- The signal interface depends on the selected control component variant
- Variable or constant air volume flow control
- The volume flow rate is measured according to the dynamic measurement principle
- Volume flow rate control range: approx. 10 – 100 % of the nominal volume flow rate

Deviation from the operating range:

- 10 – 20% of the nominal volume flow rate: +/- 25%
- 20 – 40% of the nominal volume flow rate: +/- 10%
- 40 – 100% of the nominal volume flow rate: +/- 4%

Electrical connection with cable or plug, depending on the selected control component variant.

### Technical data

- RFD nominal sizes: 160, 200, 250, 315, 400 mm
- SIRIUS nominal sizes: 125, 160, 200, 250 mm
- Volume flow rate: 4.7 – 171.4 l/s or 17 – 617 m<sup>3</sup>/h
- Supply air to room air temperature difference: -12 to +10 K

### Sizing data

- $q_v$  [m<sup>3</sup>/h]
- $\Delta p_t$  [Pa]

air-regenerated noise

- $L_{WA}$  [dB(A)]

Order code

RFD-SIRIUS – R – D – T / 160 - 250 / BC0 / E0 / 40 - 200 / P1 - RAL 9010

|
|
|
|
|
|
|
|
|

1
2
3
4
5
6
7
8
9

**1 Type**

**RFD-SIRIUS** Swirl diffuser

**2 Construction style**

**R** circular

**Q** square

**3 Construction**

No entry: without discharge nozzle

**D** with discharge nozzle

**4 Connection**

**T** Cross bar with magnet fastening and quick fixing kit

**5 Nominal size [mm]**

∅ spigot for SIRIUS plenum box

**125** (for diffuser face 160 and 200)

**160** (for diffuser face 200 and 250)

**200** (for diffuser face 250 and 315)

**250** (for diffuser face 315 and 400)

∅ spigot or nominal size of diffuser face

**160, 200, 250, 315, 400**

**6 Attachment (control component)**

**BC0** Volume flow controller with MP bus interface and analogue interface 0 – 10 V / 2 – 10 V

**BL0** Volume flow controller with LonWorks FTT-10A interface

**BM0** Volume flow controller with Modbus RTU interface

**BM0-J6** Volume flow controller with Modbus RTU interface and RJ12 socket for connecting an X-AIRCONTROL zone module

**7 Control input signal**

Only with attachment BC0

**E0** 0 – 10 V DC (variable volume flow rate)

**F0** 0 – 10 V DC (constant volume flow rate)

**E2** 2 – 10 V DC (variable volume flow rate)

**F2** 2 – 10 V DC (constant volume flow rate)

**8 Volume flow [m³/h]**

Variable

$q_{v_{min}} - q_{v_{max}}$  specify

Constant

$q_{v_{const}}$  specify

**9 Exposed surface of diffuser face**

No entry: powder-coated, RAL 9010 (pure white)

**P1** powder-coated, specify RAL CLASSIC colour

Gloss level

RAL 9010 GU 50

RAL 9006 GU 30

All other RAL colours GU 70

**Order example: RFD-SIRIUS-R-D-T/160-250/BC0/E0/40-200/P1-RAL9010**

Type	RFD-SIRIUS
Construction style	circular
Construction	with discharge nozzle
Connection	Cross bar with magnet fastening and quick fixing kit
Nominal size [mm]	∅ Connection spigot SIRIUS box 160, nominal size diffuser face 250
Attachment (control component)	Volume flow controller with MP-Bus interface and analogue interface
Control input signal	0 – 10 V DC (variable volume flow rate)
Volume flow rate [m³/h]	40 – 200
Diffuser face finish	powder-coated, RAL 9010 (pure white)

## Variants

RFD-Q-D



RFD-R-D

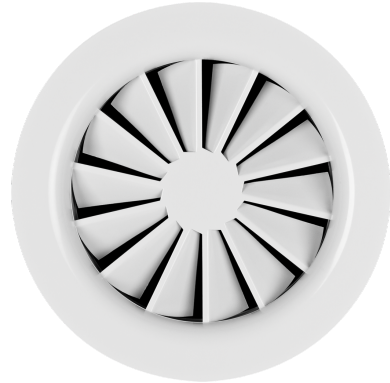

RFD-Q

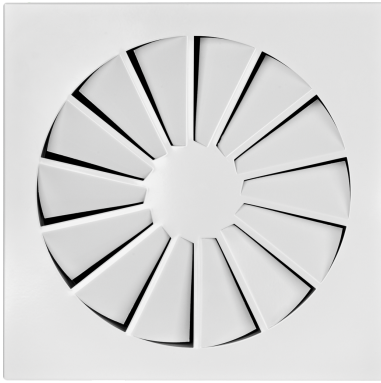

RFD-R



RFD-SIRIUS

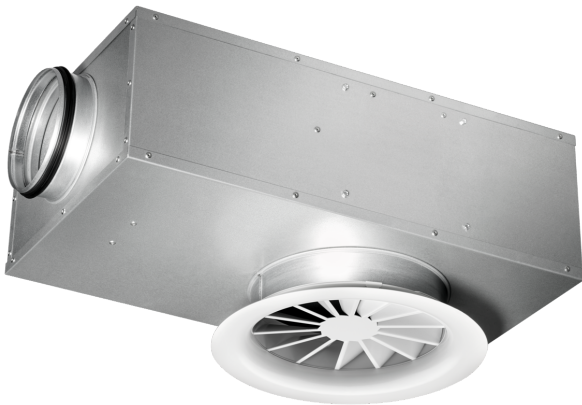

## Dimensions

### RFD-SIRIUS-Q

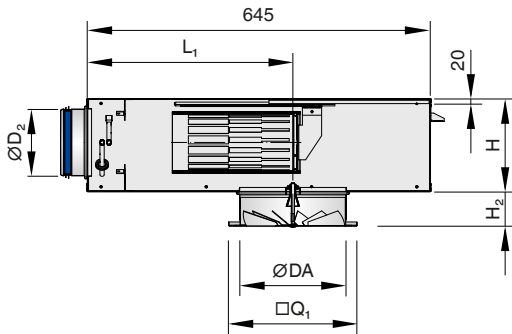

### RFD-SIRIUS-Q

NS	ØDA	□Q <sub>1</sub>	ØD <sub>2</sub>	B	L <sub>1</sub>	H	H <sub>2</sub>	A <sub>eff</sub>	m	SIRIUS weight	RFD weight
	mm								m <sup>2</sup>	kg	
RFD 160 SIRIUS 125	158	198	123	325	386	175	60	0.0037	9.2	8.5	0.7
RFD 200 SIRIUS 125	198	248	123	325	386	175	60	0.0066	9	8	1
RFD 200 SIRIUS 160	198	248	158	360	402	210	60	0.0066	10.5	9.5	1
RFD 250 SIRIUS 160	248	298	158	360	402	210	60	0.011	10.5	9	1.5
RFD 250 SIRIUS 200	248	298	198	400	435	240	60	0.011	12.5	11	1.5
RFD 315 SIRIUS 200	313	398	198	400	435	240	60	0.0205	12.9	10.5	2.4
RFD 315 SIRIUS 250	313	398	248	450	392	290	60	0.0205	14.9	12.5	2.4
RFD 400 SIRIUS 250	398	498	248	450	392	290	60	0.028	15.6	12	3.6

□Q is optional, available for all ØDA in 593, 598, 618 and 623

### RFD-SIRIUS-Q-D

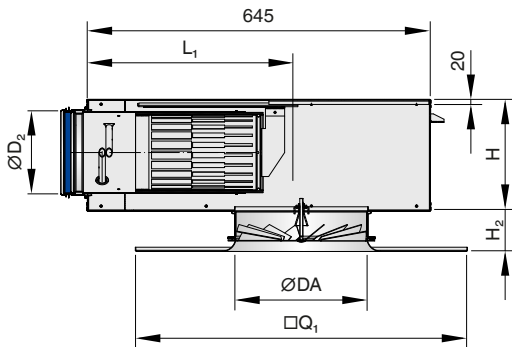

### RFD-SIRIUS-Q and RFD-SIRIUS-Q-D (RFD-SIRIUS-Q-D shown)

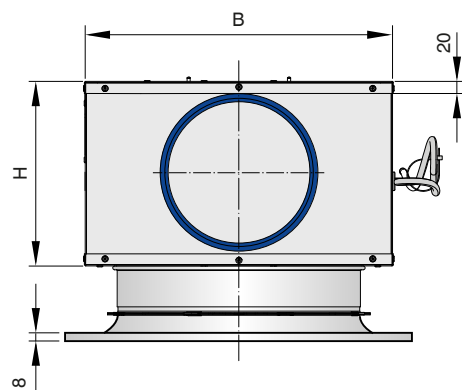

### RFD-SIRIUS-Q-D

NS	ØDA	□Q <sub>1</sub>	ØD <sub>2</sub>	B	L <sub>1</sub>	H	H <sub>2</sub>	A <sub>eff</sub>	m	SIRIUS weight	RFD weight
	mm								m <sup>2</sup>	kg	
RFD 160 SIRIUS 125	158	248	123	325	386	175	80	0.006	9.4	8.5	0.9
RFD 200 SIRIUS 125	198	248	123	325	386	175	80	0.0092	9.2	8	1.2
RFD 200 SIRIUS 160	198	248	158	360	402	210	80	0.0092	10.7	9.5	1.2
RFD 250 SIRIUS 160	248	298	158	360	402	210	80	0.015	10.7	9	1.7
RFD 250 SIRIUS 200	248	298	198	400	435	240	80	0.015	12.7	11	1.7
RFD 315 SIRIUS 200	313	398	198	400	435	240	90	0.0265	13.4	10.5	2.9

NS	ØDA	□Q <sub>1</sub>	ØD <sub>2</sub>	B	L <sub>1</sub>	H	H <sub>2</sub>	A <sub>eff</sub>	m	SIRIUS weight	RFD weight
	mm								m <sup>2</sup>	kg	
RFD 315 SIRIUS 250	313	398	248	450	392	290	90	0.0265	15.4	12.5	2.9
RFD 400 SIRIUS 250	398	498	248	450	392	290	90	0.0355	16.3	12	4.3

□Q is optional, available for all ØDA in 593, 598, 618 and 623

### RFD-SIRIUS-R

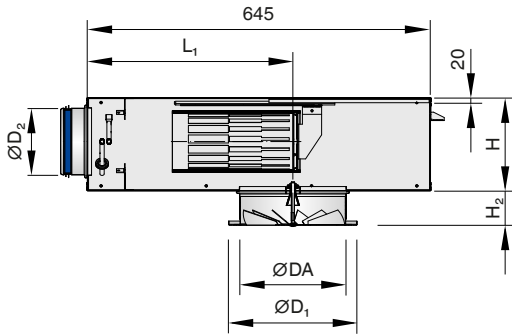

### RFD-SIRIUS-R

NS	ØDA	ØD <sub>1</sub>	ØD <sub>2</sub>	B	L <sub>1</sub>	H	H <sub>2</sub>	A <sub>eff</sub>	m	SIRIUS weight	RFD weight
	mm								m <sup>2</sup>	kg	
RFD 160 SIRIUS 125	158	197	123	325	386	175	55	0.0037	9.1	8.5	0.6
RFD 200 SIRIUS 125	198	241	123	325	386	175	55	0.0066	8.9	8	0.9
RFD 200 SIRIUS 160	198	241	158	360	402	210	55	0.0066	10.4	9.5	0.9
RFD 250 SIRIUS 160	248	295	158	360	402	210	55	0.011	10.3	9	1.3
RFD 250 SIRIUS 200	248	295	198	400	435	240	55	0.011	12.3	11	1.3
RFD 315 SIRIUS 200	313	364	198	400	435	240	55	0.0205	12.4	10.5	1.9
RFD 315 SIRIUS 250	313	364	248	450	392	290	55	0.0205	14.4	12.5	1.9
RFD 400 SIRIUS 250	398	450	248	450	392	290	55	0.028	14.9	12	2.9

RFD-SIRIUS-R-D

RFD-SIRIUS-R and RFD-SIRIUS-R-D (RFD-SIRIUS-R-D shown)

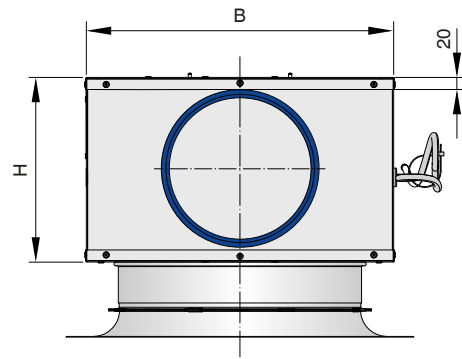
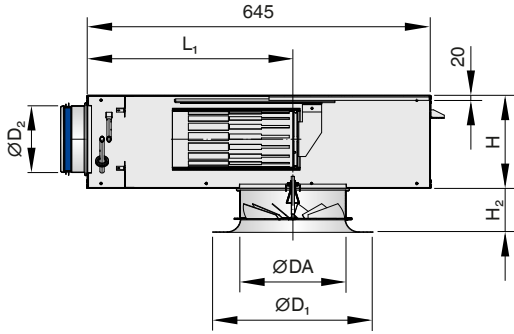

RFD-SIRIUS-R-D

NS	ØDA	ØD <sub>1</sub>	ØD <sub>2</sub>	B	L <sub>1</sub>	H	H <sub>2</sub>	A <sub>eff</sub>	m	SIRIUS weight	RFD weight
	mm							m <sup>2</sup>	kg		
RFD 160 SIRIUS 125	158	250	123	325	386	175	80	0.006	9.5	8.5	1
RFD 200 SIRIUS 125	198	300	123	325	386	175	80	0.0092	9.3	8	1.3
RFD 200 SIRIUS 160	198	300	158	360	402	210	80	0.0092	10.8	9.5	1.3
RFD 250 SIRIUS 160	248	350	158	360	402	210	80	0.015	10.8	9	1.8
RFD 250 SIRIUS 200	248	350	198	400	435	240	80	0.015	12.8	11	1.8
RFD 315 SIRIUS 200	313	450	198	400	435	240	80	0.0265	13.3	10.5	2.8
RFD 315 SIRIUS 250	313	450	248	450	392	290	80	0.0265	15.3	12.5	2.8
RFD 400 SIRIUS 250	398	580	248	450	392	290	80	0.0355	16.1	12	4.1

## Product details

### Installation in continuous ceilings



### Installation in continuous ceilings



### Installation and commissioning

- Preferably for clear room heights up to 4.0 m
- Flush ceiling installation; variant RFD-\*-D is suitable for suspended installation

### Upstream conditions

The volume flow rate accuracy  $\Delta V$  applies to a straight upstream section of the duct. Bends, junctions or a narrowing or widening of the duct cause turbulence that may affect measurement. Duct connections, e.g. branches off the main duct, must comply with EN 1505. Some installation situations require straight duct sections upstream.

### Bend

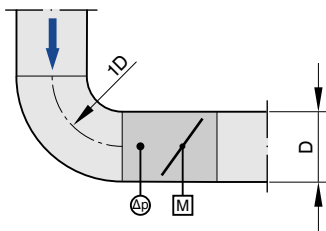

A bend with a centre line curvature radius of at least  $1D$  – without an additional straight duct section upstream of the VAV terminal unit – has only a negligible effect on the volume flow rate accuracy.

### Junction from a main duct

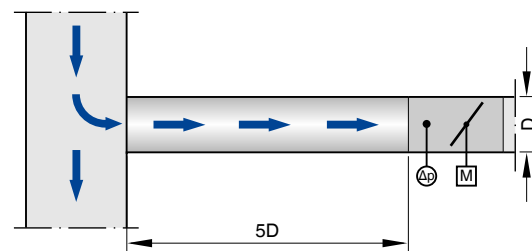

A junction from main ducts causes strong turbulence. The specified volume flow rate accuracy  $\Delta q_v$  can only be achieved with a straight duct section of at least  $5D$  upstream.

**Flush-mounted in ceiling installation**

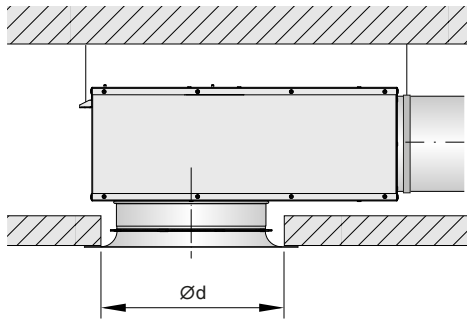

**Freely suspended installation**

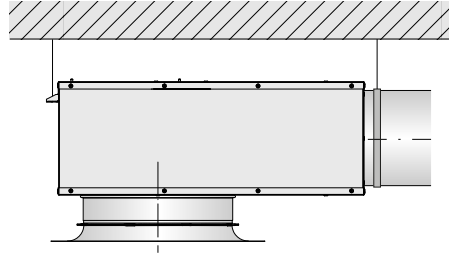

Note: Freely suspended installation is only possible with the RFD variant with nozzle or with an extended border.

**Installation opening**

NS	ØD <sub>A</sub> [mm]	Ød [mm]	
		without nozzle	with nozzle
RFD 160	158	175	205
RFD 200	198	215	245
RFD 250	248	265	295
RFD 315	313	330	380
RFD 400	398	415	480

**Installation above an open cell ceiling**

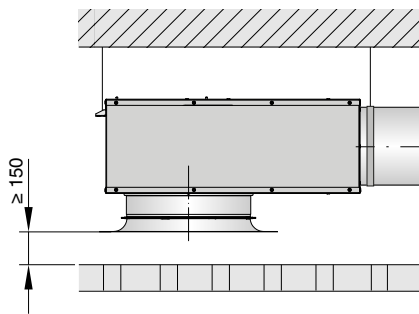

## Explanation

$\varnothing DA$  [mm]

Diameter of the spigot for connection of the diffuser face

$\square Q_1$  [mm]

Outer diameter of a square diffuser face

$\varnothing D_1$  [mm]

Outer diameter of a circular diffuser face

$\varnothing D_2$  [mm]

Diameter of the spigot for connection to the SIRIUS plenum box

$L_1$  [mm]

Distance between the outer edge of the SIRIUS plenum box on the connection side and the diffuser face centre line

$H$  [mm]

Height of the SIRIUS plenum box

$H_2$

Distance (height) between the lower edge of the diffuser face and the lower edge of the SIRIUS plenum box

$B$  [mm]

Width of the SIRIUS plenum box

$A_{\text{eff}}$  [m<sup>2</sup>]

Effective free area of the diffuser face

$m$  [kg]

Weight

$\varnothing d$  [mm]

Diameter required for the diffuser face installation opening

$D$  [mm]

Duct diameter

$L_{\text{WA}}$  [dB(A)]

A-weighted sound power level of air-regenerated noise

$q_v$  [m<sup>3</sup>/h]; [l/s]

Volume flow rate

$\Delta t_z$  [K]

Supply air to room air temperature difference, i.e. supply air temperature minus room temperature

$\Delta p_t$  [Pa]

Total differential pressure

$A_{\text{eff}}$  [m<sup>2</sup>]

Effective air discharge area

All sound power levels are based on 1 pW.