



Slot diffusers

PURELINE35

TROX SE

Heinrich-Trox-Platz
47506 Neukirchen-Vluyn
Germany
Phone: +49 (0) 2845 202-0
Fax: +49 (0) 2845 202-265
E-Mail: trox-de@troxgroup.com
<http://www.troxgroup.com>

Product overview

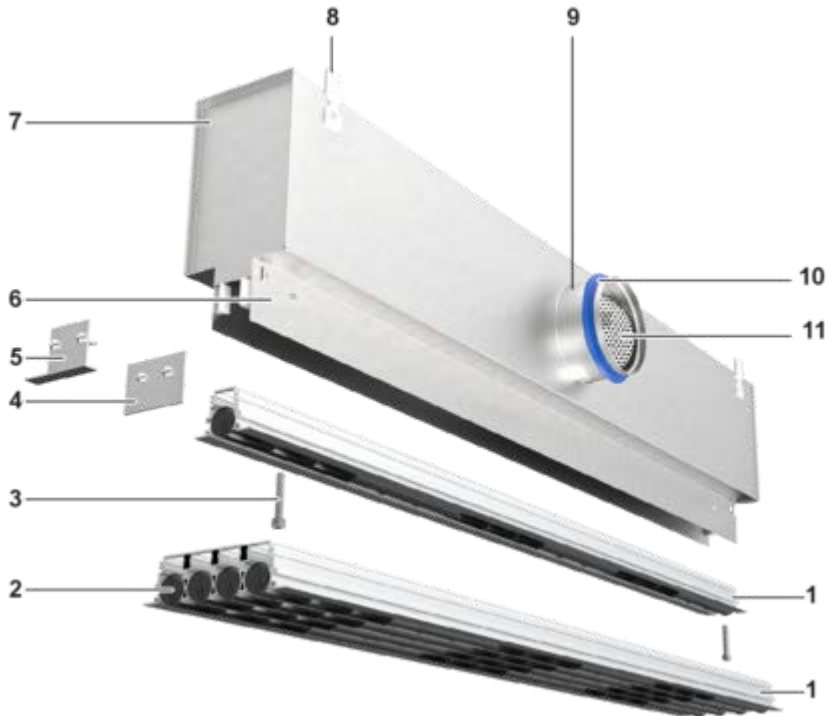

Fig. 1: Schematic illustration example PL35-*-SF

- | | | | |
|---|------------------------------------|----|--|
| 1 | Front rail with 1, 2, 3 or 4 slots | 7 | Plenum box |
| 2 | Adjustable air control element | 8 | Suspension lug |
| 3 | Screw fixing | 9 | Spigot |
| 4 | End plate | 10 | Lip seal |
| 5 | End angle | 11 | Damper blade for volume flow balancing |
| 6 | Neck | | Optional equipment: 4, 5, 10, 11 |

Important notes

Information on the installation manual

These instructions enable correct installation as well as safe and efficient handling.

Personnel must have read and understood these instructions carefully before starting any work. The basic prerequisite for safe working is to comply with all safety notes and instructions in this manual.

The local regulations for health and safety at work and general safety regulations also apply.

Other applicable documentation

In addition to this manual, the following documents must be observed:

- Product data sheets

Explanation of symbols

Safety notes

Symbols are used in this manual to alert readers to areas of potential hazard. Signal words express the degree of the hazard.

Comply with all safety instructions and proceed carefully to avoid accidents, injuries and damage to property.



DANGER!
Imminently hazardous situation which, if not avoided, will result in death or serious injury.



WARNING!
Potentially hazardous situation which, if not avoided, may result in death or serious injury.



CAUTION!
Potentially hazardous situation which, if not avoided, may result in minor or moderate injury.



NOTICE!
Potentially hazardous situation which, if not avoided, may result in property damage.



ENVIRONMENT!
Environmental pollution hazard.

Limitation of liability

All information and instructions in this manual have been compiled taking into account the applicable standards and regulations, the state of the art and our many years of knowledge and experience.

The manufacturer does not accept any liability for damages resulting from:

- Non-compliance with this manual
- Unintended or improper use

- Operation or handling by untrained individuals
- Unauthorised modifications

The actual scope of delivery may differ from the explanations and illustrations provided in this manual for special versions, the use of additional order options or as a result of recent technical changes.

Safety

Intended use

Air diffusers are used for the ventilation of rooms in industrial and comfort areas. The air diffusers are connected to a supply air or extract air system (provided by the client), which is typically connected to a central air handling unit.

Air diffusers are used to supply cooled or heated air to rooms (within the specified supply air to room air temperature differences).

Depending on the area of application, special hygiene requirements must be observed during installation, operation, and maintenance.

Possible installation in humid rooms, areas with potentially explosive atmospheres, or rooms with dust-laden or aggressive air must be assessed individually.

Personnel

Qualification

HVAC technician

HVAC technicians are individuals who have sufficient professional or technical training in the field they are working in to enable them to carry out their assigned duties at the level of responsibility allocated to them and in compliance with the relevant guidelines, safety regulations and instructions. HVAC technicians are individuals who have in-depth knowledge and skills related to HVAC systems; they are also responsible for the professional completion of the work under consideration.

HVAC technicians are individuals who have sufficient professional or technical training, knowledge and actual experience to enable them to work on HVAC systems, understand any potential hazards related to the work under consideration, and recognise and avoid any risks involved.

Trained personnel

Trained personnel are individuals who have sufficient professional or technical training, knowledge and actual experience to enable them to carry out their assigned duties, understand any potential hazards related to the work under consideration, and recognise and avoid any risks involved.

Personal protective equipment

Personal protective equipment must be worn for any work in order to reduce health or safety hazards to the minimum.

The appropriate protective equipment for a job must be worn for as long as the job takes.

Industrial safety helmet



Industrial safety helmets protect the head from falling objects, suspended loads, and the effects of striking the head against stationary objects.

Protective gloves



Protective gloves protect hands from friction, abrasions, punctures, deep cuts, and direct contact with hot surfaces.

Safety shoes



Safety shoes protect the feet from crushing, falling parts and prevent slipping on a slippery floor.

Repair and replacement parts

Only qualified personnel may repair the products, and they have to use genuine replacement parts.

Transport and storage

Delivery check

After delivery, carefully remove the packaging and check the device for any transport damage and completeness. In case of transport damage or incomplete delivery, inform the forwarding agent and the supplier immediately. After inspection of the goods, put the product back into its packaging to protect it from dust and contamination.



Fixing and installation material

Unless otherwise specified, fixing and installation materials are not included in the delivery and must be provided by the client, in accordance with the respective installation situation.



Factory setting

The air control blades are factory-set to a certain position. Changing the air control blades leads to increased efforts during commissioning. Therefore, avoid moving the air control blades during on-site transport, unpacking and installation.

Transport on site



CAUTION!

Risk of injury from sharp edges, sharp corners and thin sheet metal parts!

Sharp edges, sharp corners and thin-walled sheet metal parts can cause abrasions and cuts to the skin.

- Be careful when carrying out any work.
- Wear protective gloves, safety shoes and a hard hat.

Observe the following points during transport:

- Be careful when unloading or moving the product on site, and pay attention to the symbols and information on the packaging.
- If possible, take the product in its transport packaging up to the installation location.
- Use only lifting and transport gear designed for the required load.
- During transport, always secure the load against tipping and falling.
- Bulky equipment should be transported by at least two people to prevent injury and damage.

Storage

Observe the following points for storage:

- Store the product only in its original packaging
- Protect the product from the effects of weather
- Protect the product from humidity, dust and contamination
- Storage temperature: -10 °C to 90 °C
- Relative humidity: 80 % maximum, no condensation

Packaging

After unpacking, properly dispose of packaging material.

Installation

General installation information

Observe during installation:

- For room heights up to 4 m (lower edge of ceiling)
- Flush ceiling installation
- Only attach the device to load-bearing parts of the building.
- Only load the suspensions with the device's own weight. Adjacent components and connecting air ducts must be supported separately.
- For cleaning purposes, the air diffusers must be easily accessible after installation.
- Installation and sealing materials provided by the manufacturer are usually enclosed in a bag in the package.



Protect the device from contamination

Before installation, ensure that the air-ducting components cannot be contaminated by construction activities (VDI 6022). If this is not possible, at least cover the devices or take other precautions to protect them from contamination. In this case, make sure the device is not in operation. Ensure that all components are clean before you install them. Clean thoroughly if necessary. When interrupting the installation procedure, protect all device openings from the ingress of dust or humidity.

Installation in panelled ceilings

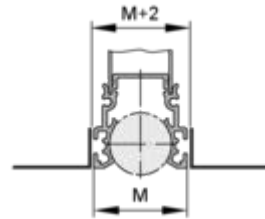

Fig. 4: Slot diffuser without extended border

Length of installation opening with end plate: $L1 + 9$ mm

Installation in ceiling systems

Installation in T-bar ceilings

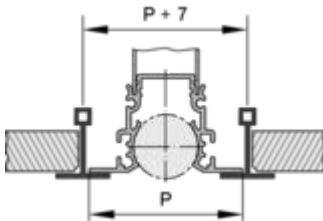

Fig. 2: Slot diffuser with extended border

Length of installation opening with end angle:
 $L1 + 29$ mm

Installation in continuous ceilings

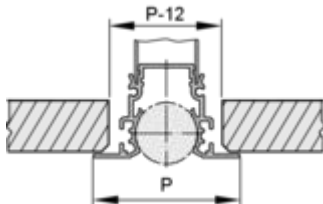

Fig. 3: Slot diffuser with extended border

Length of installation opening with end angle: $L1 + 9$ mm

Installation of plenum box

Plenum box suspension

Personnel:

- Trained personnel
- HVAC technician

Protective equipment:

- Industrial safety helmet
- Protective gloves
- Safety shoes

If possible, install the slot diffuser before fixing the ceiling tiles. If this is not possible, remove the adjacent ceiling tiles.

Use only approved and adequately sized suspensions for fixing (fixing material not included in the scope of supply). Consider weights ↪ *Chapter 7.1 'Dimensions and weights' on page 14.*

For larger dimensions, we recommend that two people carry out the installation or that a lift be used as an aid.

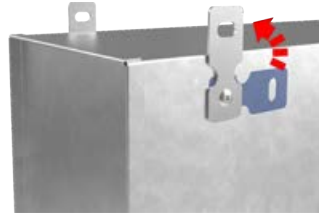

- 2 ▶ Turn the suspension lugs upwards
- 3 ▶ When using threaded rods, bend the suspension lugs once by approx. 90°.
- 4 ▶ It is recommended to secure the threaded rod with nuts at the top and bottom.
- 5 ▶ Attach the plenum box to all factory-provided suspension points.

Air connection

The spigot connects the device to the air duct system. Variants with a lip seal are sufficiently tight; no additional sealing material required.

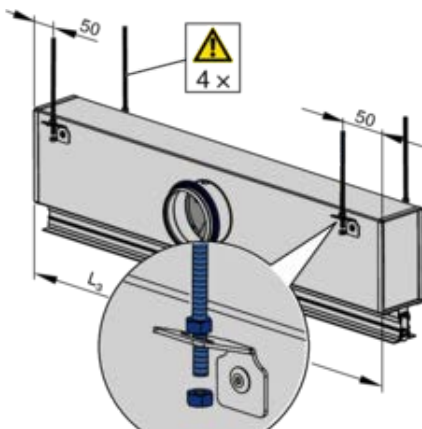

Fig. 5: Plenum box suspension

- 1 ▶ Fixing elements, e.g. threaded rods, etc., must be fastened to the ceiling.

Installation of front rail

Connection of the slot diffuser

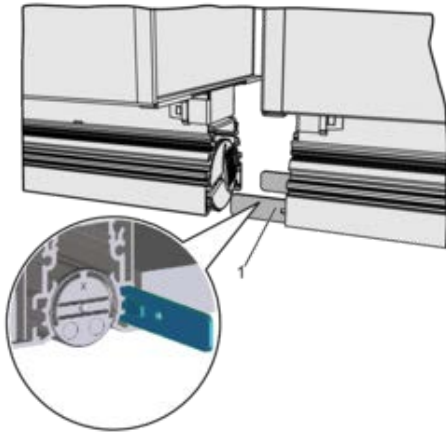

Fig. 6: Installation of slot diffusers

For continuous linear arrangement of slot diffusers, the front rails are aligned using the supplied connectors.

Put the connectors (2 per front rail) into place on one side, then push them halfway into the next front rail. First, the connector side with embossing must be inserted correctly up to the centre of the connector.

Connection of the corner section CS

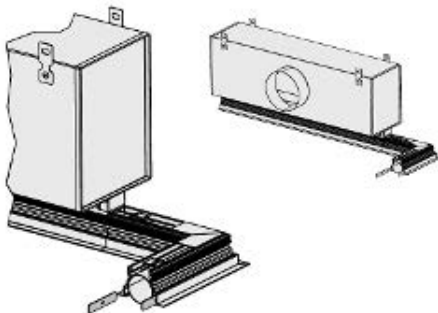

Fig. 7: Mounting the corner section CS

The corner section is fixed into place on site. The corner section is positioned on the front rail with the enclosed connectors (2 pieces per corner section). Fix the connectors into place on one side, then push them halfway into the front rail. First, the connector side with embossing must be inserted correctly up to the centre of the connector.

Connection of transfer rail CD and blind rail BD

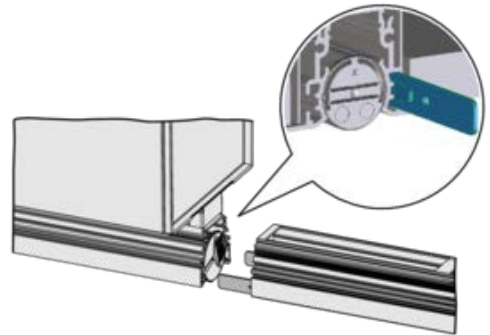

Fig. 8: Mounting of transfer rail CD and blind rail BD

The transfer rail and blind rail are fixed into place on site. The supplied connectors (2 pieces per front rail) are used to position and align the transfer rail and blind rail. On site, fix the connectors into place on one side, then push them halfway into the next front rail. First, the connector side with embossing must be inserted correctly up to the centre of the connector.

End plate EP

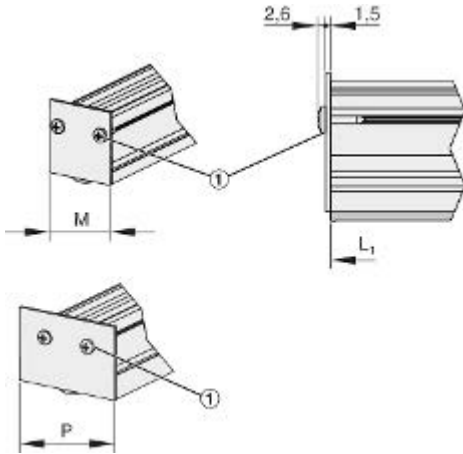

Fig. 9: End plate EP without / with extended border

End angle EA

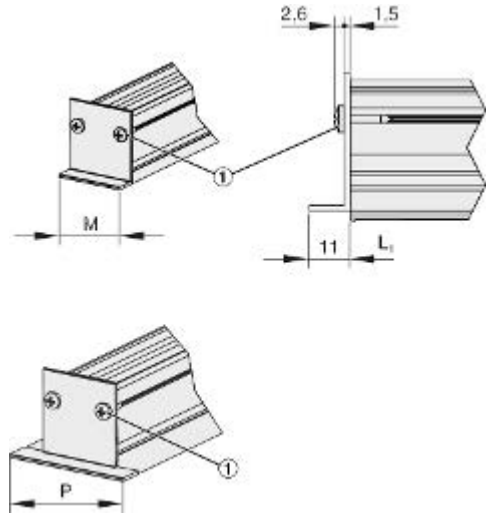

Fig. 10: EA end angle without / with extended border

! NOTICE!

When combining front rails with extended borders and end plates, make sure that the installation opening cannot be covered. The installation opening can only be covered with an end angle.

Single diffusers are factory-fitted with end plates or end angles. For continuous linear arrangement, two end pieces (1 pair) are required to close off the front rail. The end pieces must be fitted on site, using screws to fix the end plates or end angles. ↗ (Fig. 9/1) and (Fig. 10/1)

Diffuser face fixing

Mounting the fixed diffuser face fixing

The diffuser face of the PF variant is firmly connected to the plenum box and must not be dismantled during installation. The slot diffuser must be installed before the suspended ceiling is built.

Mounting the detachable diffuser face fixing

For slot diffusers with detachable diffuser face fixing (variant SF or DS+PB), the diffuser face can be fixed to the plenum box after the suspended ceiling has been completed.

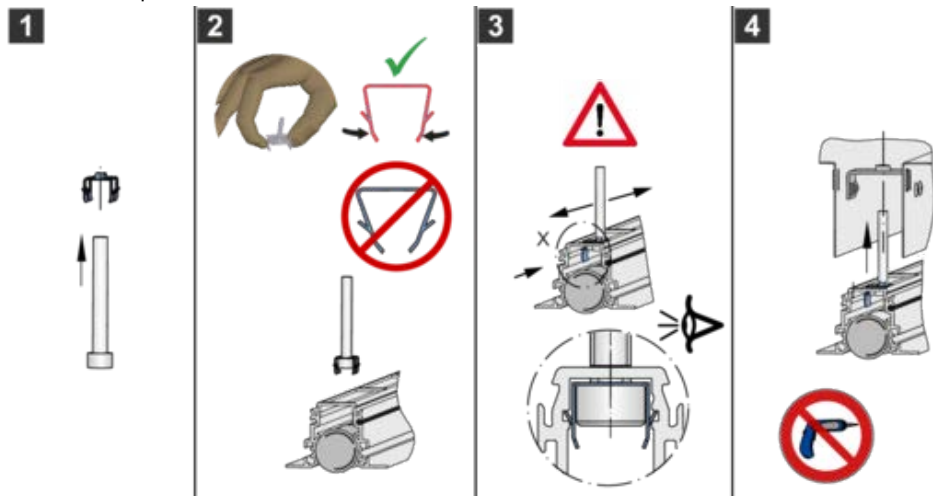

Fig. 11: Front rails with detachable diffuser face fixing

1. Mount the loose fixing material as shown.
2. Press the clamp together slightly and insert it into the back of the front rail, but do not compress the clamp too much.
3. Check and position the fixing material in the groove, positioning it as shown in Figure Fig. 13 to Fig. 16.
4. Using the screws, insert the diffuser face into the mounting points provided on the cross bar on the plenum box. Using an Allen key (4 mm) simplifies the fixing procedure. To remove the diffuser face, first undo the Allen screws (4mm Allen key).

Arrangement of the fixing points in the cross bar

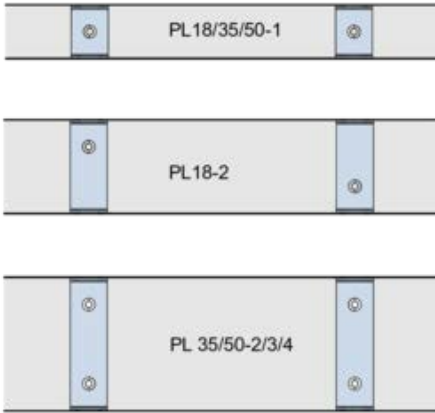

Fig. 12: Assignment of the cross bar for fastening the front rail
Positioning the fastening material on the front rail

Front rail on the right longer than plenum box

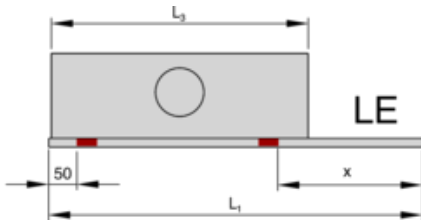

Fig. 13: Front rail longer than plenum box, position of plenum box LE, $X = (L_1 - L_3) + 45$

Front rail on the left longer than plenum box

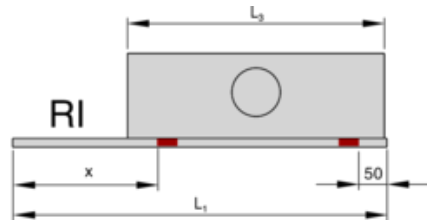

Fig. 14: Front rail longer than plenum box, position of plenum box RI, $X = (L_1 - L_3) + 45$

Front rail on both sides longer than plenum box

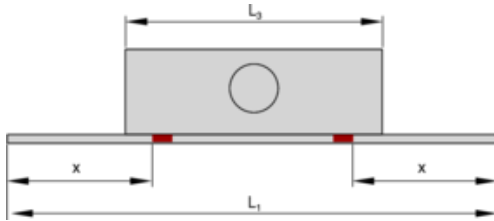

Fig. 15: Front rail longer than plenum box, centre position of plenum box, $X = (L_1 - L_2) / 2 + 45$

Front rail same length same as the plenum box

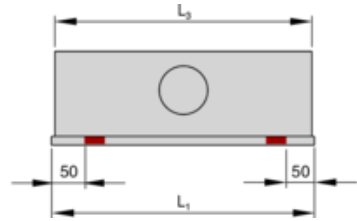

Fig. 16: Front rail length = plenum box length

Front rail DF – Installation into continuous ceiling with spring clip fixing

Note: only for air diffusers with extended border B00 and without end piece or with end angle. The end plate variant is not possible in combination with front rail -DF.

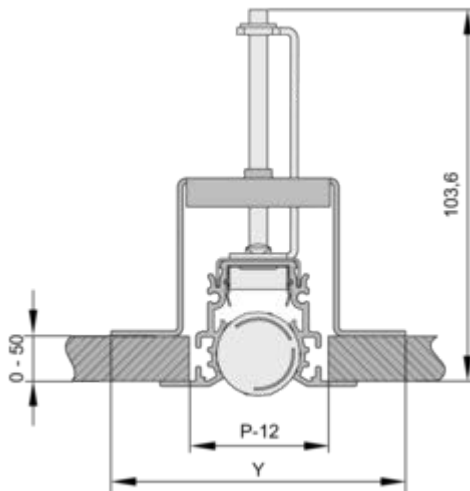

Fig. 17: Position of the crossbar, ceiling thickness up to 50 mm

Variant	Y_{max}	Variant	Y_{max}
PL35-1-*-DF	79	PL35-3-*-DF	133
PL35-2-*-DF	106	PL35-4-*-DF	160

Mounting the crossbar fixing DF

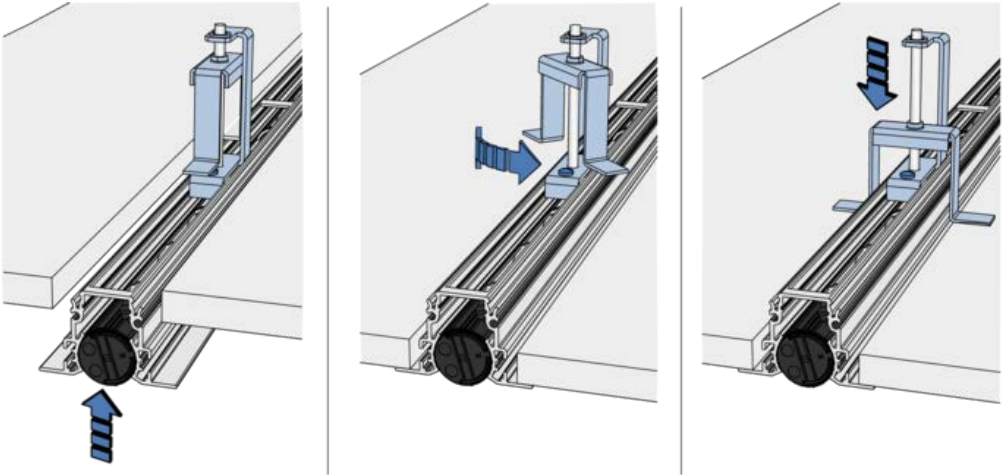

Fig. 18: Crossbar fixing - DF

Retrofitting crossbar fixing DF

If necessary, the crossbar fixing can be retrofitted. The front rail with extended border B00 is required for retrofitting. Mounting is carried out on site (by the client) depending on the length of the front rail, as shown in the following images. Installation of the front rail in the ceiling according to Fig. 17

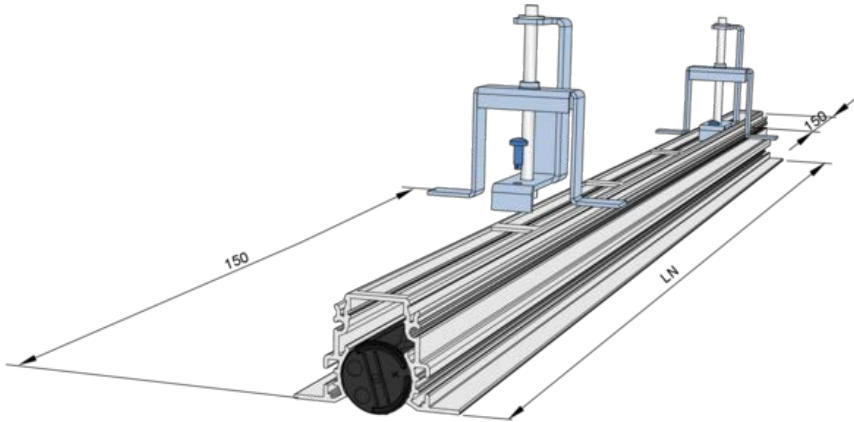

Fig. 19: 2 fixing points up to $L_N < 1500$ mm

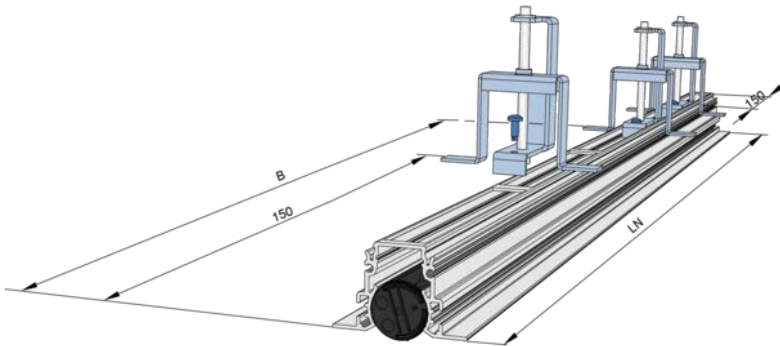

Fig. 20: 3 fixing points from $L_N \geq 1500$ mm

L_N [mm]	B [mm]
600 - 1350	–
1500	750
1650	750

L_N [mm]	B [mm]
1800	900
1950	900

Technical data

Dimensions and weights

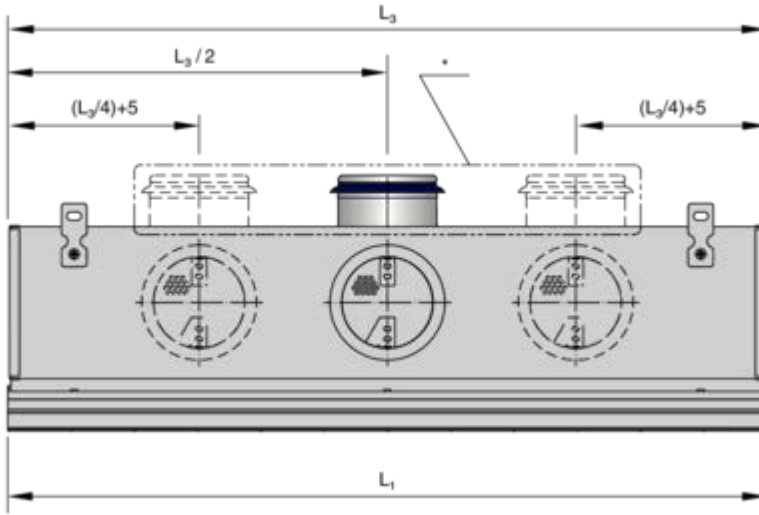

Fig. 21: Dimensions and spigot arrangement, * spigot arrangement for plenum box variant VS

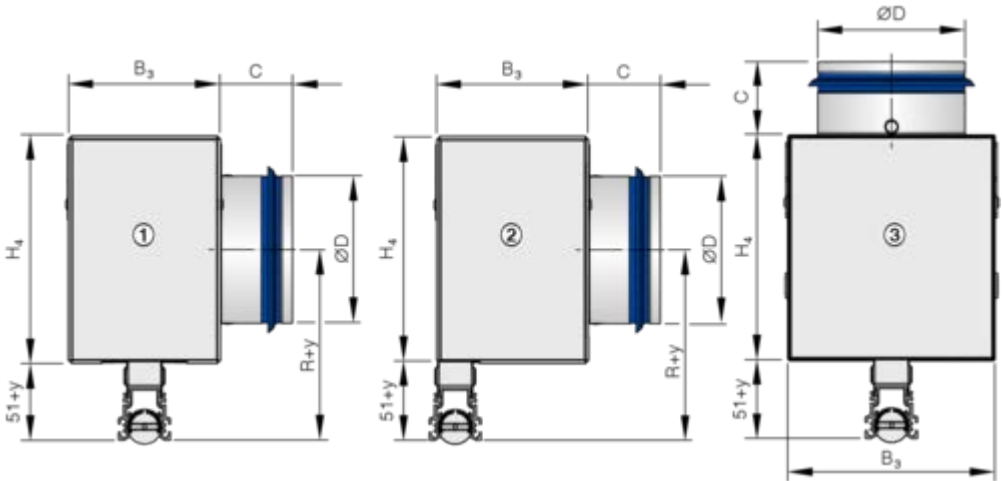

Fig. 22: Plenum box variants

- 1 PL35*-HS (symmetric position of plenum box, side entry spigot)
- 2 PL35*-HA (asymmetric position of plenum box, side entry spigot)
- 3 PL35*-VS (symmetric position of plenum box, top entry spigot)

L _N	L ₁ [mm]	L ₃ [mm]
600	600	595
750	750	745
900	900	895
1050	1050	1045
1200	1200	1195
1350	1350	1345
1500	1500	1495
1650	1650	1645
1800	1800	1795
1950	1950	1945

Plenum box variant	Weight [kg/m]			
	Number of slots			
	1	2	3	4
Front rail	0.8	1.2	1.6	2.1
Plenum box HS/HA	3.3	3.9	4.6	5.2
Plenum box HS/HA+L (lining)	4.0	4.7	5.5	6.2
Plenum box VS	3.7	3.9	4.1	4.3
Plenum box VS+L (lining)	4.5	4.7	4.9	5.2

Total weight [kg] = front rail + plenum box
Enter lengths in metres [m]

Variant	B ₃ [mm]		H ₄ [mm]	
	HS/HA	VS	HS/HA	VS
PL35-1	100	138	150	150
PL35-2	138	160	180	
PL35-3	176	176	198	
PL35-4	214	214	230	

Variant	R + Y [mm]
PL35-1	126 + Y
PL35-2	141 + Y
PL35-3	150 + Y
PL35-4	166 + Y

Neck extension Y = 30 / 55 / 80 / 105 / 129

Variant	ØD [mm]	C [mm]
PL35-1	98	50
	123	48
PL35-2	123	48
	138	42
PL35-3	138	42
	158	50
PL35-4	158	50
	198	50

Front rails

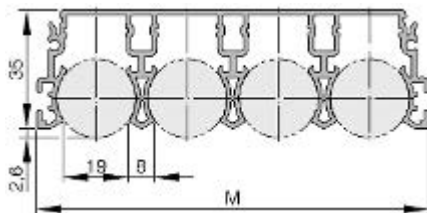

Fig. 23: PL35-4

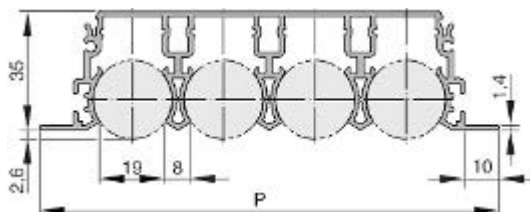

Fig. 24: PL35-4/B00

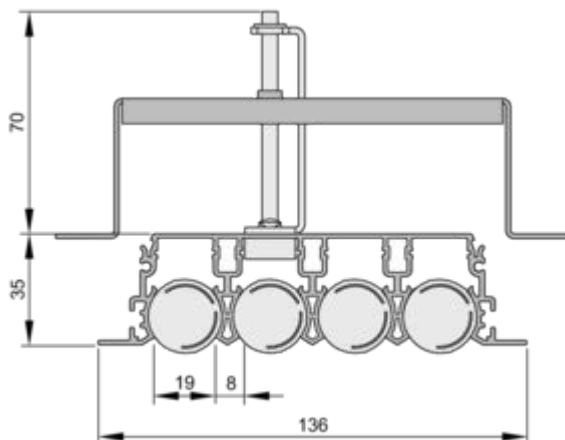

Fig. 25: PL35-4-DF/.../B00

Variant	M [mm]	P [mm]
PL35-1	35	55
PL35-2	62	82

Variant	M [mm]	P [mm]
PL35-3	89	109
PL35-4	116	136



Setting the airflow direction

These are only schematic diagrams to illustrate the setting of the air control blades.

The air control blades have notches on the mullions which are used for adjustment. If necessary, we recommend that you use both hands to adjust the air control blades on the notches.

Airflow – ceiling installation

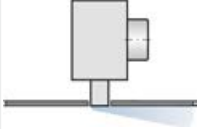
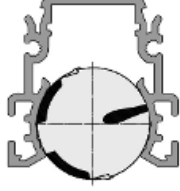
Airflow direction	Setting the air control blades		
Alternating horizontal air discharge			<p data-bbox="642 501 1049 550">Air control elements alternately set to left-hand or right-hand air discharge</p>
Alternating angled air discharge			<p data-bbox="642 804 1049 855">Air control elements alternately set to left-hand or right-hand air discharge</p>
Vertical air discharge			
One-way horizontal air discharge to the left			

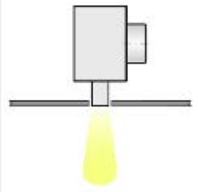
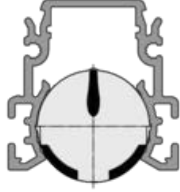
Airflow direction		Setting the air control blades	
One-way horizontal air discharge to the right			
Extract air			
		With and without air control element	

Initial commissioning

General information

Before commissioning, check the following points:

- Check that the air diffusers are fitted correctly.
- Remove all protective foils.
- Ensure that all air diffusers are clean and free from residues and foreign matter.
- Check electrical connections (if any) for correct installation.
- Check proper fastening and connection with air duct

For commissioning, see also VDI 6022, Sheet 1 - Hygiene requirements for ventilation and air conditioning systems and units.

Volume flow balancing

When several slot diffusers are connected to just one volume flow controller, it may be necessary to balance the volume flows.

Slot diffusers with plenum box and damper unit: The damper unit can also be operated when the diffuser face is installed.

Move the air control blades near the spigot in such a way that it is possible to insert a screwdriver or cord.

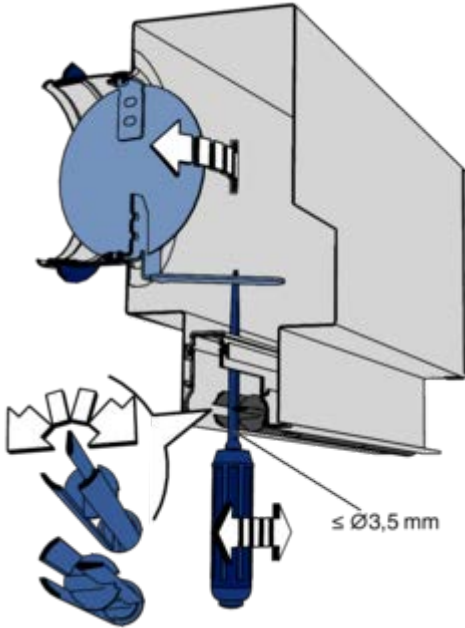

Fig. 26: Setting the damper unit with a horizontal spigot, e. g. with a screwdriver

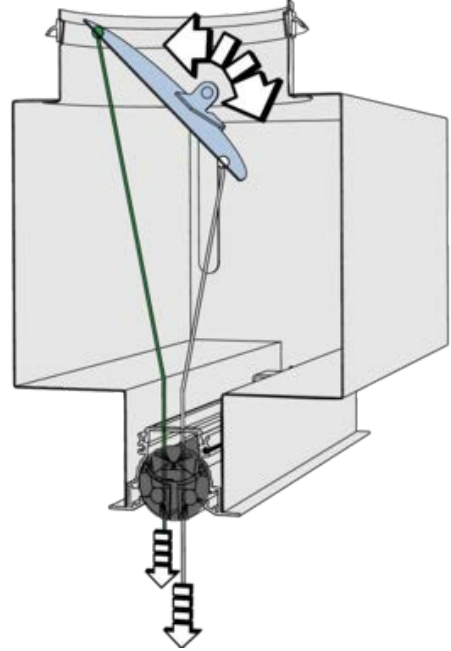

Fig. 27: Setting the damper unit with a vertical spigot

When pulling the cords:

white cord - opens damper unit

green cord - closes damper unit

Maintenance

System owner's responsibility



WARNING!

Only authorised specialist personnel may perform the described maintenance measures.

The system owner is responsible for maintenance. With their maintenance management, the system owner is responsible for creating a maintenance plan, for defining the maintenance goals, and for the functional reliability of the equipment.

The legal regulations must be observed during maintenance, e.g. the system owner is responsible for hygienic operation in accordance with VDI 6022.

Maintenance and cleaning

During cleaning, the following points must be observed:

- The cleaning intervals given in the VDI 6022 standard apply.
- Clean surfaces with a damp cloth.
- Use only common household cleaners, do not use any aggressive cleaning agents.
- Do not use cleaning agents that contain chlorine.
- Do not use equipment for removing stubborn contamination, e.g., scrubbing sponges or scouring cream, as it may damage the surfaces.

Inspection measures

- 1 ▶ Remove contamination that affects the function of the wall diffuser.
- 2 ▶ Check all screw connections for tightness and retighten them, if necessary.
- 3 ▶ Document the maintenance work.

Repair work

Repair work is only allowed to be carried out by specialist personnel or by the manufacturer. Only original spare parts may be used.

Disposal



ENVIRONMENT!

Risk of harm to the environment due to incorrect disposal!

Incorrect disposal may harm the environment.

- Be sure to comply with the relevant national guidelines and regulations.
- In case of doubt, contact your local authorities or a specialist disposal company.

Note: The wall diffuser must be dismantled for disposal.

If no disposal or return agreements with TROX SE are in place, we recommend disposing of the materials as follows:

Pos.	Component	Material/ waste code	Type of disposal
1	Front rail, end angle	Aluminium EWC 170402	Scrap metal recycling
2	Plenum box, spigot	galvanised steel EWC 170404	Scrap metal recycling
3	Air control blades	Plastic EWC 170203	according to the EWC
5	Insulating mat	Mineral wool EAK 170603	according to the EWC

EWC European Waste Catalogue