



AHU

X-CUBE X2 compact 2

Device construction Rxx, RxxV, Pxx



TROX[®] TECHNİK

The art of handling air

TROX GmbH

Heinrich-Trox-Platz

47504 Neukirchen-Vluyn

Germany

Phone: +49 2845 202-0

Fax: +49 2845 202-265

Email: trox-de@troxgroup.com

Internet: <http://www.troxtechnik.com>

A00000094316, 4, GB/en

12/2024

© TROX GmbH 2022

About this manual

This transport and installation manual enables operating or service personnel to use the X-CUBE air handling unit (AHU) safely and efficiently.

The manual must be kept near the unit to be available for use at all times.

This transport and installation manual is intended for use by fitting and installation companies, operators, in-house technicians, technical staff or instructed persons, and skilled qualified electricians or air conditioning technicians.

It is essential that these individuals read and fully understand this manual before starting any work. The basic prerequisite for safe working is to comply with the safety notes and all instructions in this manual.

The local regulations for health and safety at work and the general safety regulations for the area of application of the air handling unit also apply.

Illustrations in this transport and installation manual are mainly for information and may differ from the actual design of the air handling unit.

Other applicable documentation

In addition to these instructions, the following documents apply:

- Order-specific approval drawing
- Order-specific air handling unit data sheet from TROX
- Data sheets for components from other suppliers, if any
- Circuit diagram for air handling unit with controls
- Additional drawings, if any
- X-CUBE operating manual

TROX Technical Service

To ensure that your request is processed as quickly as possible, please keep the following information ready:

- Product name
- TROX order number
- Delivery date
- Brief description of the fault

Online	www.troxtechnik.com
Phone	+49(0)2845 202400

Copyright

This document, including all illustrations, is protected by copyright and pertains only to the corresponding product.

Any use without our consent may be an infringement of copyright, and the violator will be held liable for any damage.

This applies in particular to:

- Publishing content
- Copying content
- Translating content
- Microcopying content
- Saving content to electronic systems and editing it

Limitation of liability

The information in this manual has been compiled with reference to the applicable standards and guidelines, the state of the art, and our expertise and experience of many years.

The manufacturer does not accept any liability for damages resulting from:

- Non-compliance with this manual
- Incorrect use
- Operation or handling by untrained individuals
- Unauthorised modifications
- Technical changes
- Use of non-approved replacement parts

The actual scope of delivery may differ from the information in this manual for bespoke constructions, additional order options or as a result of recent technical changes.

The obligations agreed in the order, the general terms and conditions, the manufacturer's terms of delivery, and the legal regulations in effect at the time the contract is signed shall apply.

We reserve the right to make technical changes.

Warranty claims

The provisions of the respective general delivery terms apply to warranty claims. For purchase orders placed with TROX GmbH, these are the regulations in section "VI. Warranty claims" of the Delivery Terms of TROX GmbH, see www.troxtechnik.com.

Safety notes

Symbols are used in this manual to alert readers to areas of potential hazard. Signal words express the degree of the hazard.

Comply with all safety instructions and proceed carefully to avoid accidents, injuries and damage to property.

DANGER!

Imminently hazardous situation which, if not avoided, will result in death or serious injury.

WARNING!

Potentially hazardous situation which, if not avoided, may result in death or serious injury.

CAUTION!

Potentially hazardous situation which, if not avoided, may result in minor or moderate injury.

NOTICE!

Potentially hazardous situation which, if not avoided, may result in property damage.

ENVIRONMENT!

Environmental pollution hazard.







Tips and recommendations



Useful tips and recommendations as well as information for efficient and fault-free operation.





Specific safety notes

The following symbols are used in safety notes to alert you to specific hazards:

Warning signs	Type of danger
	Warning - danger of crushing.
	Warning – hand injuries.
	Warning – high-voltage.
	Warning – danger of falling.
	Warning – suspended load.
	Warning – danger zone.

Additional markers

In order to highlight instructions, results, lists, references and other elements, the following markers are used in this manual:

Marker	Explanation
 1., 2., 3. ...	Step-by-step instructions
	Results of actions
	References to sections in this manual and to other applicable documents
	Lists without a defined sequence
[Switch]	Operating elements (e.g. push buttons, switches), display elements (e.g. LEDs)
'Display'	Screen elements (e.g. buttons or menus)

1	Overview	6	5.6.2	Tube connections of differential pressure sensors	45
2	Safety	10	5.6.3	Connection of accessories	48
	2.1 System owner's responsibility	10	5.7	Connecting the AHU to the power supply	52
	2.2 Personnel requirements	10	5.8	Integrating the air handling unit with the MCE	52
	2.3 Personal protective equipment	11	5.9	Connecting the air handling unit to your PC or local network	52
	2.3.1 Residual risks	11	5.10	Setting the bus address for accessories	53
	2.3.2 Behaviour in the event of hazardous situations or accidents	13			
3	Transport and storage	14	6	Initial commissioning	54
	3.1 Delivery of the air handling unit	14	6.1	Safety notes regarding initial commissioning	54
	3.1.1 Kind of delivery	14	6.2	Before initial commissioning	54
	3.1.2 Symbols on the packaging	14	6.3	Setting up and adjusting AHU casing units	55
	3.2 Delivery check	14	6.3.1	☺ Centrifugal fan	55
	3.3 Moving packages	15	6.3.2	➤ Filter unit	57
	3.3.1 Safety notes regarding transport	15	6.3.3	☒ Heating coil/cooling coil	57
	3.3.2 Moving packages with a forklift or pallet truck	16	6.3.4	Electric air heater	58
	3.3.3 Moving packages with a crane	17	6.3.5	☒ Multileaf dampers	59
	3.4 Storage and functional integrity	18	6.3.6	☒ Sound attenuator	59
	3.4.1 Storage	18	6.3.7	☒ Rotary heat exchanger	59
	3.4.2 Functional integrity of components	18	6.3.8	☒ Plate heat exchanger	60
	3.5 Unpacking	19	6.3.9	Electrical system	61
	3.5.1 Removing transport protection devices	19	6.4	Starting the air handling unit	61
4	Setup and assembly	20	6.4.1	Before you start the AHU	61
	4.1 Safety notes	20	6.4.2	Activating accessories	61
	4.2 Requirements for the installation location	21	6.4.3	Deactivating accessories	62
	4.2.1 Requirements for indoor installation	21	6.4.4	Switching on	63
	4.2.2 Requirements for outdoor installation	22	6.5	Configuring the air handling unit	63
	4.3 Preventing vibration and structure-borne noise	22	6.5.1	X-CUBE controller communication, setup	63
	4.4 Setting up and assembling the AHU	23	6.5.2	Setting up network communication	64
	4.4.1 Setting up the AHU or AHU casing units	23	6.6	Logging in to the web server	66
	4.4.2 Assembling AHU casing units	25	7	Disassembly and disposal	67
	4.4.3 Additional assembly steps for outdoor units	28	7.1	Safety notes regarding disassembly and disposal	67
	4.4.4 Installing accessories	30	7.2	Dismantling	68
	4.5 Mounting levelling feet	33	7.3	Disposal	68
5	Installation	34	8	Glossary	70
	5.1 Safety notes regarding installation	34	9	Index	71
	5.2 Before installation	34		Appendix	73
	5.3 Connecting the condensate drain	35	A	Circuit diagrams for electric air heaters	74
	5.4 ☒ Connecting the heating coil/cooling coil	37			
	5.5 ☒ Connecting the steam heat exchanger	39			
	5.6 Wiring	40			
	5.6.1 Connections and interfaces	42			

1 Overview



Fig. 1: Exemplary device with rotary heat exchanger X2-Rxx

- | | | | |
|---|---------------------|----|--|
| 1 | Casing | 7 | Levelling feet |
| 2 | Mains isolator | 8 | Inspection access door (see table for an explanation of the symbols) |
| 3 | Touch panel | 9 | Door lock |
| 4 | Cable glands | 10 | Door handle |
| 5 | Connecting subframe | 11 | Shut-off dampers |
| 6 | Base frame | | |

An X-CUBE air handling unit is shipped either fully assembled or in parts (AHU casing units), depending on construction and installation situation. Each AHU casing unit comes with a drawing that shows the correct installation position.

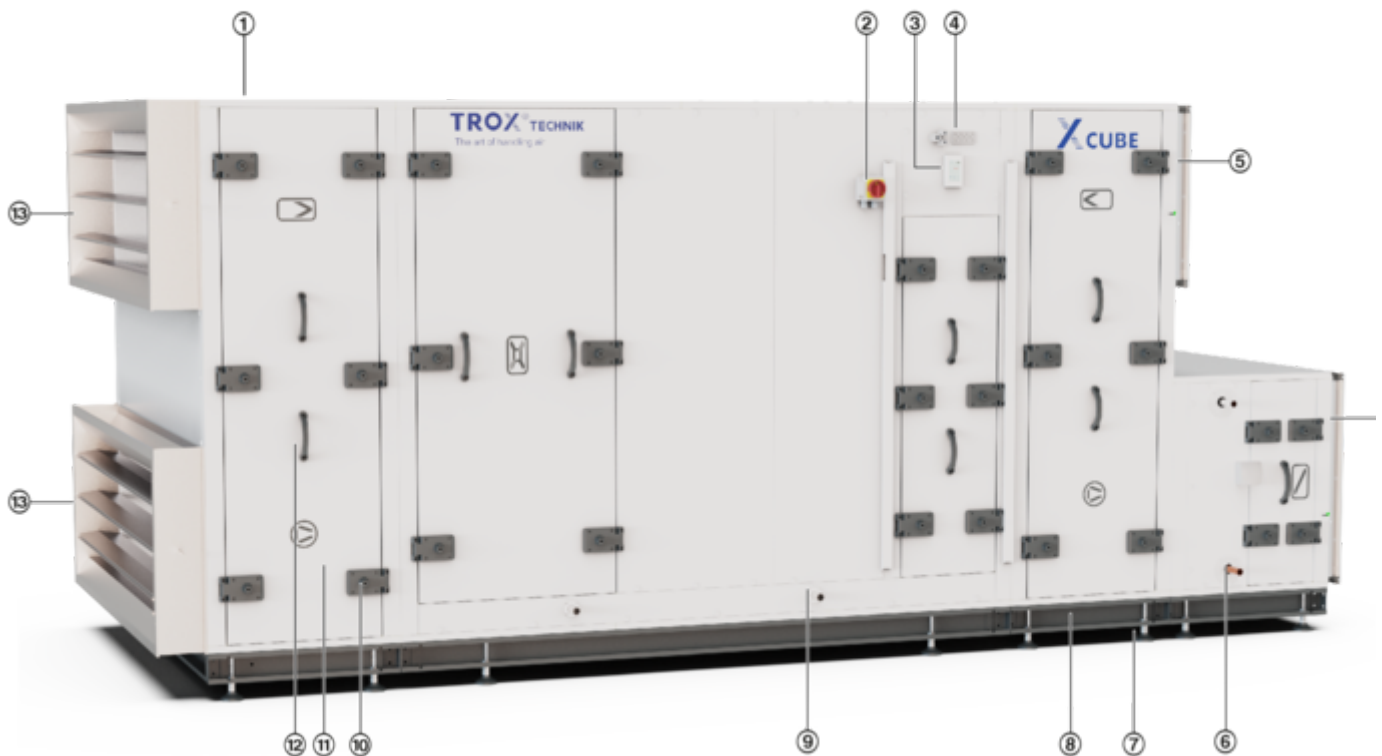

Fig. 2: Exemplary device with plate heat exchanger X2-Pxx

- | | | | |
|---|------------------------------------|----|--|
| 1 | Casing | 8 | Base frame |
| 2 | Mains isolator | 9 | Condensate drain, connection for drain trap |
| 3 | Touch panel | 10 | Door lock |
| 4 | Cable glands | 11 | Inspection access door (see table for an explanation of the symbols) |
| 5 | Connecting subframe | 12 | Door handle |
| 6 | Water connections (heat exchanger) | 13 | Shut-off damper |
| 7 | Levelling feet | | |

An X-CUBE air handling unit is shipped either fully assembled or in parts (AHU casing units), depending on construction and installation situation. Each AHU casing unit comes with a drawing that shows the correct installation position.









Fig. 3: Exemplary device with rotary heat exchanger and vertical air connection X2-RxxV

- | | | | |
|---|--|----|---------------------|
| 1 | Casing | 6 | Levelling feet |
| 2 | Touch panel | 7 | Base frame |
| 3 | Mains isolator | 8 | Door handle |
| 4 | Cable glands | 9 | Door lock |
| 5 | Inspection access door (see table for an explanation of the symbols) | 10 | Connecting subframe |

An X-CUBE air handling unit is shipped either fully assembled or in parts (AHU casing units), depending on construction and installation situation. Each AHU casing unit comes with a drawing that shows the correct installation position.

The following table lists the components that can make up an air handling unit. The components actually used for a particular air handling unit are listed in the order-specific technical data sheet.

AHU casing units

Symbol	Designation
	Multileaf dampers
	Filters
	Centrifugal fan
	Cooling coil
	Heating coil
	Plate heat exchangers
	Rotary heat exchanger

2 Safety

2.1 System owner's responsibility

System owner

The system owner is a natural or legal person who for commercial or business purposes owns or manages the air handling unit or allows third parties to use or operate it, but continues to bear legal responsibility for the safety of users, staff or third parties while the product is in use.

System owner's obligations

The unit is intended for commercial use. The system owner is therefore subject to the legal obligations of occupational health and safety regulations.

In addition to the safety notes in this manual, the applicable regulations for safety, accident prevention and environmental protection must also be complied with.

In particular:

- The system owner must establish on site a coherent fire protection strategy and include the air handling unit in this strategy.
- The system owner must establish on site a coherent lightning protection strategy and include the air handling unit in this strategy.
- The system owner must name responsible persons for transport, storage, assembly, installation, commissioning, transfer, disassembly and removal of the unit.
- The system owner must commission a skilled qualified electrician to create equipotential bonding.
- The system owner has to ensure that all individuals who handle or use the air handling unit have read and understood this manual.
- The system owner must provide the employees with the required personal protective equipment.
- The system owner must have all safeguards tested regularly to ensure that they are functional and complete.
- The system owner must ensure compliance with the national legal provisions.
- The system owner must have technical and hygiene tests carried out and documented before commissioning the air handling unit for the first time. The tests have to be repeated at regular intervals.

2.2 Personnel requirements

WARNING!

Danger of injury or risk of damage to property due to insufficiently qualified individuals!

Insufficiently qualified individuals are not aware of the risks involved in working with the air handling unit and are hence likely to put themselves or others into danger, causing severe or fatal injuries.

- Have any work carried out only by qualified personnel.
- Keep insufficiently qualified individuals away from the work area.

Crane driver

Crane drivers are physically and mentally able to operate a crane on their own.

Crane drivers are qualified to operate a crane and have proven the required skillset to the system owner.

Crane drivers are commissioned by the system owner to move units from the delivery truck to the installation location. Crane drivers are commissioned in writing if the crane is a mobile crane.

Crane drivers have to be at least 18 years old.

Forklift driver

Forklift drivers are qualified to operate driver-operated forklift trucks; they are commissioned in writing by the system owner to operate such a truck.

Forklift drivers are responsible for moving pallets.

HVAC technician

HVAC technicians are individuals who have sufficient professional or technical training in the field they are working in to enable them to carry out their assigned duties at the level of responsibility allocated to them and in compliance with the relevant guidelines, safety regulations and instructions. HVAC technicians are individuals who have in-depth knowledge and skills related to HVAC systems; they are also responsible for the professional completion of the work under consideration.

HVAC technicians are individuals who have sufficient professional or technical training, knowledge and actual experience to enable them to work on HVAC systems, understand any potential hazards related to the work under consideration, and recognise and avoid any risks involved.

Network administrator

Network administrators design, install, configure and maintain the IT infrastructure in companies or organisations.

Qualified electrician

Skilled qualified electricians are individuals who have sufficient professional or technical training, knowledge and actual experience to enable them to work on electrical systems, understand any potential hazards related to the work under consideration, and recognise and avoid any risks involved.

Skilled qualified electrician

Skilled qualified electricians are individuals who have sufficient professional or technical training, knowledge and actual experience to enable them to work on electrical systems, understand any potential hazards related to the work under consideration, and recognise and avoid any risks involved.

2.3 Personal protective equipment**Description of personal protective equipment****Hearing protection**

Hearing protection protects against hearing damage resulting from noise exposure.

Industrial safety helmet

Industrial safety helmets protect the head from falling objects, suspended loads, and the effects of striking the head against stationary objects.

Protective clothing

Protective clothing is close-fitting, with low tear resistance, close-fitting sleeves, and no projecting parts.

Protective gloves

Protective gloves protect hands from friction, abrasions, punctures, deep cuts, and direct contact with hot surfaces.

Safety harness

A safety harness protects people from a fall when they are working at height. You are at risk from a fall if the task is at height and if there is no railing in place.

When you put on a safety harness, connect it via an energy-absorbing lanyard to a suitable anchor point.

Safety harnesses must only be used by individuals who have been specifically trained to use them.

Safety shoes

Safety shoes protect the feet against crushing, falling parts, and from slipping on slippery ground.

2.3.1 Residual risks**Suspended loads****DANGER!****Danger of death due to suspended loads!**

Falling loads may cause serious injury or death.

Therefore:

- Never walk under suspended loads.
- Only move loads under supervision.
- Observe the specifications for the intended lashing points.
- Do not attach the lifting gear to protruding machine parts or lugs on attached components
- Ensure that the lifting gear is secure.
- Only use approved hoisting devices and lifting gear with sufficient load-bearing capacity.
- Do not use any frayed or worn ropes and belts.
- Do not place ropes or belts near sharp edges or corners; do not knot or twist.
- Place the load on the ground before leaving the workplace.

Industrial trucks

 **WARNING!****Danger to life from industrial trucks!**

Objects and other loads could fall in an uncontrolled manner from industrial trucks during transport and cause serious injuries or even death. There is also the risk that people will not be seen and could thus be run over by the vehicle driver.

- Industrial trucks may only be operated by trained vehicle drivers (e.g. forklift drivers).
- People should only pass industrial trucks when the vehicle driver has signalled that they have seen them.
- Only approved industrial trucks with sufficient load-bearing capacity may be used.
- Materials should never be transported in the vicinity of people or the zones occupied by people.

Electric current

 **DANGER!****Danger of death due to electric current!**

Danger of electric shock! Do not touch any live components! Damaged insulation or damaged parts are a life threatening hazard.

- Have work on the electrical system carried out only by skilled qualified electricians.
- Have work on the electrical system carried out only by skilled qualified electricians.
- If the insulation is damaged, disconnect the power supply immediately and have the insulation repaired.
- Before you start working on electric systems and equipment, switch off the supply voltage and secure it against being switched on accidentally. Comply with the 5 safety rules:
 - Disconnect.
 - Secure it against being switched on accidentally.
 - Ensure that no voltage is present.
 - Connect to the earth; short circuit connection.
 - Either cover nearby parts that carry a voltage or install barriers.
- Do not bypass or disable any circuit breakers. Be sure to maintain the correct current rating when you replace a circuit breaker.
- Ensure that live parts do not come into contact with moisture. Moisture can cause a short circuit.

Dirt and objects lying around

 **CAUTION!****Risk of injury from falling as a result of dirt or objects lying around!**

Dirt and objects lying around can lead to the risk of slipping and tripping. Injuries can be caused by falling.

- Work areas should always be kept clean.
- Objects that are no longer required should be removed from the work area, particularly those that are near the floor.
- Tripping hazards that cannot be avoided should be marked with yellow and black marking tape.

Tools

 **CAUTION!****Risk of injury as a result of the negligent handling of tools!**

Negligent handling of tools can lead to crushing or cuts.

- Tools must be handled carefully and as intended.
- The weight must be taken into account when transporting tools.
- Protective gloves and safety shoes should be worn.

Rotating parts

 **WARNING!****Risk of injury from rotating parts!**

Rotating parts in the fan can cause serious injuries.

- Do not reach into or handle the moving impeller wheel during operation.
- Do not open inspection access doors and covers during operation.
- Ensure that the impeller wheel is not accessible during operation.
- Observe the run down time! Check that no parts are moving before you open an inspection access door or cover.
- Switch off the unit and secure it against being switched back on again before starting any work on moving fan components. Wait until all parts have come to a standstill.

Noise**WARNING!****Hearing damage due to noise!**

The noise level in the work area can cause severe hearing damage.

- Always wear hearing protection while working.
- Only remain in the hazardous area if absolutely necessary.

Measures in the event of accidents

- Trigger an emergency stop immediately, and put the isolator into the “0” position if necessary.
- Implement first aid measures.
- Rescue individuals from the hazardous area.
- Inform the responsible person at the operation site.
- Notify the emergency services.
- Clear access paths for rescue vehicles.

Crushing hazard!**WARNING!****Crushing hazard from movable parts!**

There is an increased risk of crushing on casing units, doors, panels and components of the device.

- Never reach between moving parts.
- Be careful when carrying out any work.
- Wear protective gloves, safety shoes and a hard hat.

Inspection access doors slamming shut**WARNING!****Risk of crushing from doors slamming shut**

Inspection access doors may slam shut by the wind or if someone pushes them inadvertently, resulting in serious injury to the head and limbs.

- Secure each inspection access door with a hold open device.
- Secure inspection access doors without a hold open device against closing by suitable means.
- Do not reach between the door and door frame.
- Wear protective gloves and a hard hat when you open an inspection access door.

2.3.2 Behaviour in the event of hazardous situations or accidents**Preventive measures**

- Always be prepared for accidents or fire!
- Keep first aid equipment (first aid kit, blankets, etc.) and fire extinguishers close at hand.
- Familiarise personnel with accident reporting, first aid and rescue equipment.
- Keep access paths for rescue vehicles clear.

3 Transport and storage

3.1 Delivery of the air handling unit

3.1.1 Kind of delivery

Upon delivery, check the air handling unit for transport damage and completeness, see [Chapter 3.2 'Delivery check'](#) on page 14.

Depending on its size, the air handling unit is shipped either fully assembled or in parts, with the individual components or casing units screw-fixed to square edge timber frames or disposable pallets.

The number of parts is shown on a drawing on the package.



External components may be shipped unassembled to protect them from getting entangled with transport slings while being moved. These components have to be properly installed and sealed by others.

3.1.2 Symbols on the packaging

The packaging carries the following marks and symbols. Be sure to follow them when you are moving the unit.



The packaging may also carry other symbols, notes, and information. These must also be followed.

Accessories



Fig. 4: Accessories

Packages with this sticker contain AHU accessories.

3.2 Delivery check

Check delivered items immediately after arrival for transport damage and completeness. In case of any damage or an incomplete shipment, contact the shipping company and your supplier immediately. If any parts are missing, have the driver confirm them on the consignment note.

Otherwise the manufacturer will not accept any liability.



See the notes on shipping damage on the packaging or in the shipping papers.

For any claims it is necessary that you follow the procedure below. In each of the following cases do contact TROX before you start installing a unit.

The packaging has been damaged

- Unpack the goods in the presence of the person who has delivered the goods and have them confirm the damage on the shipping order.
- Photograph the damage.
- Report the damage to TROX immediately.

No external damage to packaging, contents damaged.

- Photograph the damage.
- Report the damage to TROX immediately in writing.
- Note that shipping damage must be reported within four days of delivery.

3.3 Moving packages

3.3.1 Safety notes regarding transport

Improper transport equipment

! WARNING!

Risk to life from using improper transport equipment!

If packages are lifted without adequate transport equipment and if they are not properly secured, they may fall off and lead to fatal injuries.

- Move components only in the position in which they are to be installed.
- Stand clear of suspended loads.
- Do not move additional loads on top of a package.
- Use only the intended lashing points.
- Make sure that no load is imposed on pipes, ducts or cables.
- Use only approved lifting gear and slings that are suitable and sufficient for the load to be carried.
- Do not tie ropes and chains or make knots or place them on sharp edges.
- Use lifting equipment only to lift packages or units, not to push or pull them.
- Ensure that ropes, belts and chains do not twist.
- Ensure that transport equipment has been correctly assembled, fastened and secured before you use it to lift anything.
- Secure all doors, dampers and panels.
- Move packages without any jerky movements and put them down when you leave your workplace.
- Lifting eyes are designed for one-time use only and not for permanently suspending loads.
- Transport tubes are designed for one-time use only and not for permanently suspending loads.

🔗 2.3.1 'Residual risks' on page 11

Warning: AHU casing units may tip over



! WARNING!

Risk of injury from AHU casing units tipping over!

Tall AHU casing units with a small footprint, e.g. rotary heat exchangers, may easily tip over and therefore pose an increased risk during unloading, transportation and installation.

Be sure to take adequate precautions:

- Use additional means to secure the casing units, e.g. ratchet straps (by others).
- Use only lifting and transport gear designed for the required load.
- Keep the casing units secured against shifting and tipping over until installation is complete.

Unbalanced loads and centre of gravity

! WARNING!

Risk of injury from falling or toppling loads!

Loads may be unbalanced, i.e. the centre of gravity may not be obvious. If the load is not properly attached to the lifting equipment, it may topple and fall. Falling or toppling loads can cause serious injuries.

- Note that the centre of gravity is marked on each package.
- When you use a crane to move loads, ensure that the centre of gravity of the load is directly beneath the crane hook.
- Lift any load carefully and keep an eye on it to see whether it will stay in place. If required, change the lashing point(s).

Sticker indicating the centre of gravity

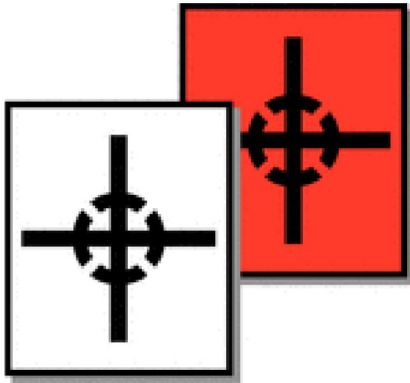

Fig. 5: Shipping stickers

Stickers on the packaging indicate the centre of gravity (Fig. 5).

Sharp edges, sharp corners and thin sheet metal parts

⚠ CAUTION!

Danger of injury from sharp edges, sharp corners and thin sheet metal parts!

Sharp edges, sharp corners and thin sheet metal parts of the heat exchanger or of the cooling or heating coil may cause cuts or grazes.

- Be careful when working on these components.
- Wear protective gloves, safety shoes and a hard hat.

Damage to goods being moved

! NOTICE!

Risk of damage to property due to the incorrect handling or lifting of units!

If you handle or move packages incorrectly, they may topple or fall. This can cause considerable damage to property.

- Do not put down packages hard and do not knock against them with force. Watch out for protruding parts.
- When you are moving units for outdoor installation, be careful that the thin metal roof is not damaged by the lifting gear.

3.3.2 Moving packages with a forklift or pallet truck

Air handling units differ in weight and may have different lashing points. See the order-specific technical documents for details.

Personnel:

- Forklift driver

Protective equipment:

- Industrial safety helmet
- Protective clothing
- Protective gloves
- Safety shoes

! NOTICE!

Risk of damage to property from forklifts or pallet trucks!

Take proper precautions when you use a forklift or pallet truck to move or lift parts or components of an air handling unit as otherwise they may be damaged.

- If you want to use a forklift to lift a package without a base frame, you need to protect the casing units properly.

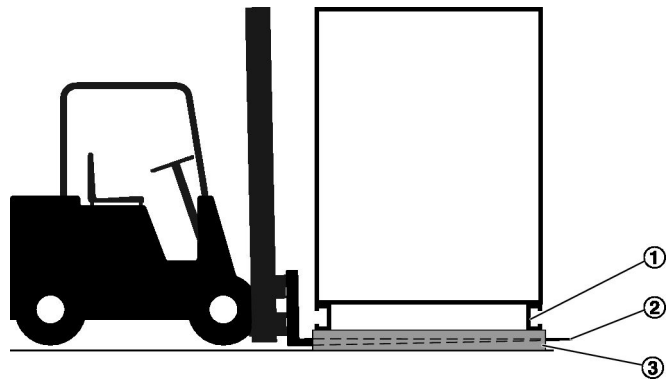

Fig. 6: Carrying load with a forklift

1. ▶ Drive the forklift forward until the forks (Fig. 6 /3) are fully between the square edge timber sections of the pallet (Fig. 6 /2) and protrude from underneath the base frame (Fig. 6 /1) on the opposite side.
2. ▶ Ensure that the load cannot tip.
3. ▶ Slowly lift the load and start moving.

3.3.3 Moving packages with a crane

Personnel:

- Crane driver

Protective equipment:

- Industrial safety helmet
- Protective clothing
- Safety shoes
- Protective gloves

⚠ WARNING!

Danger to life from falling AHU components!

If you overload lashing points or lifting gear, the load may fall down. There is danger to life.

- Always use at least four lashing points.
- Use only adequate lifting gear and slings.
- Stand clear of suspended loads.

! NOTICE!

Damage to property due to the incorrect handling or lifting of units

Take proper precautions when using a crane to move or lift parts of an AHU as otherwise they may be damaged.

For transport, note the following:

- Transport the AHU casing units only at holes in the base frame.
- Pass the round slings through one pair of holes each.
- Do not use ropes or chains.
- Do not use shackles or other rigid holding devices on the base frame.
- If external components could be damaged by lifting, use an alternative pair of holes.
- Protect the edges of the AHU casing units with wood blocks.
- Keep the slings (round slings) apart with suitable spreading devices, e.g., a spreader beam.

If a unit has to be moved with different equipment, contact TROX beforehand to discuss the details.

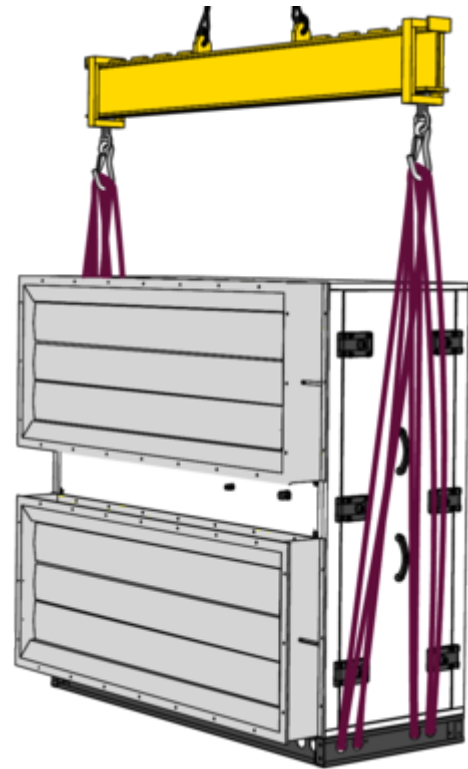

Fig. 7: Lashing to base frame on operating and rear side

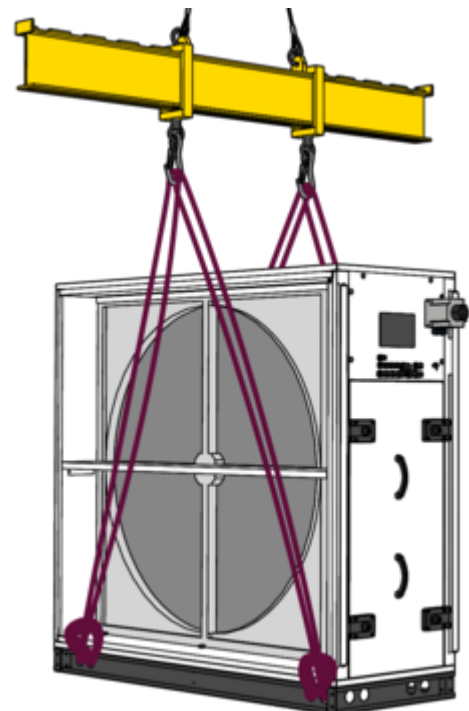

Fig. 8: Round sling slung with loop

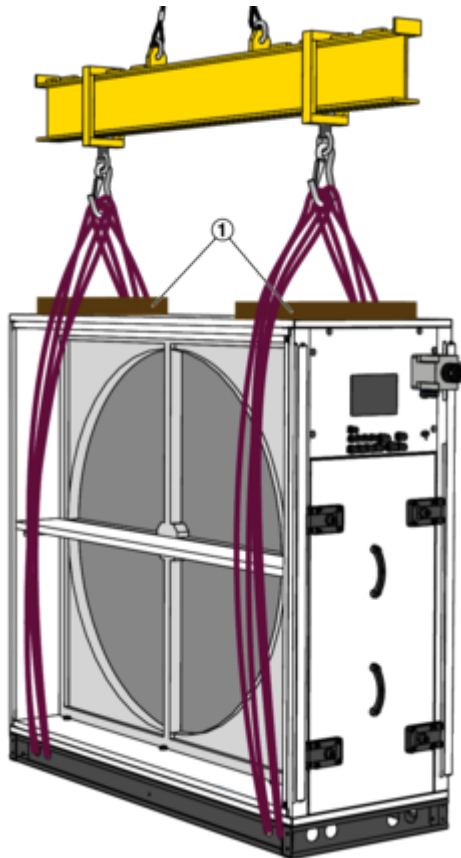

Fig. 9: Lashing with inserted spacer timber

1 Spacer timbers

1. ▶ Guide the round slings through two holes (pair of holes) in the base frame at each of four lashing points.

Protect the edges of the equipment using a spreader beam (Fig. 7 and Fig. 8) or spacer timbers (Fig. 9 /1).

Components/equipment with roof:

- Spread the slings in the roof area with a suitable spreading device, e.g., a spreader beam.
- Select spacer timbers so that a distance of 100 mm is guaranteed between the sling and the device.

Note during attachment/lifting:

- Do not spread slings by more than 60°.
- Ensure that the slings cannot damage the AHU unit.
- Suspend (distribute) the load symmetrically, i.e. in such a way that its centre of gravity is beneath the crane hook.

2. ▶ Slowly lift the AHU load and start moving.

3.4 Storage and functional integrity

3.4.1 Storage

! NOTICE!

Risk of damage to property due to corrosion!

Insufficient ventilation due to film packaging can result in condensation and, hence, oxidation on galvanised surfaces, e.g. white rust.

- Remove film packaging immediately after delivery.
- Store all units in a dry, well-ventilated place.

In the case of Sendzimir-galvanised units, corrosion may occur on the cut edges. Reddish or whitish discolouration of the cut edge does not indicate problematic corrosion. Corrosion protection is still guaranteed. This does not indicate a reduction in quality and there are no grounds for complaint.

Please note the following storage conditions:

- Do not store outdoors.
- Store in a dry and dust-free place that is not exposed to sunlight.
- Storage temperature: -10 °C to +50 °C; avoid sudden/major fluctuations in temperature.
- Provide unpackaged units with protective packaging and ensure sufficient ventilation in order to prevent condensation.
- Seal openings in the units to ensure that no dust or vermin can get inside.
- Do not expose the units to aggressive operating fluids.
- The storage location must be level and have sufficient load-bearing capacity.
- If storing the units for more than 3 months, refer to the information on functional integrity. ↪ on page 18

i Note!

If there are storage instructions on the packaging, these instructions must be followed as well.

3.4.2 Functional integrity of components

When storing or shutting down the units or if commissioning is to be carried out at a later date (units out of operation for more than 3 months), take the following measures to ensure their functional integrity.

- Rotating or moving components such as fans, rotary heat exchangers, multileaf dampers, actuators, valves or pumps should be rotated/moved on a monthly basis.
- In the case of belt-driven components, slacken the belts.

- Check the general condition of all parts and of the packaging. Refresh corrosion protection, if necessary.
- Document any measures taken.

In the case of frequency inverters, EC controllers (period without supply voltage >1 year), additional measures may be necessary. Please refer to the relevant manufacturer documentation.

3.5 Unpacking

Packaging

The packaging depends on how the packages are being shipped. Only environmentally-friendly materials have been used for the packaging.

The packaging is intended to protect the components from damage, including transport damage, and corrosion. Do not destroy the packaging and do not remove it until you are ready to install the components.



ENVIRONMENT!

Note on disposing of single-use packaging

The packaging is purely transport packaging, which has been reduced to the absolute minimum with regard to transport and unloading.

Packaging materials can, in many cases, be reconditioned and recycled.

- Dispose of packaging materials in an environmentally friendly manner in accordance with the local waste disposal regulations.
- If necessary, employ a specialist disposal company to dispose of the packaging.

3.5.1 Removing transport protection devices

Always move AHU casing units with the transport protection devices in place; remove transport protection devices only when the unit has reached its final position.

Transport protection device for the fan (only on X-CUBE)

X-CUBE Compact units have only EC fans that are screw-fixed to the casing and consequently do not require transport protection devices.

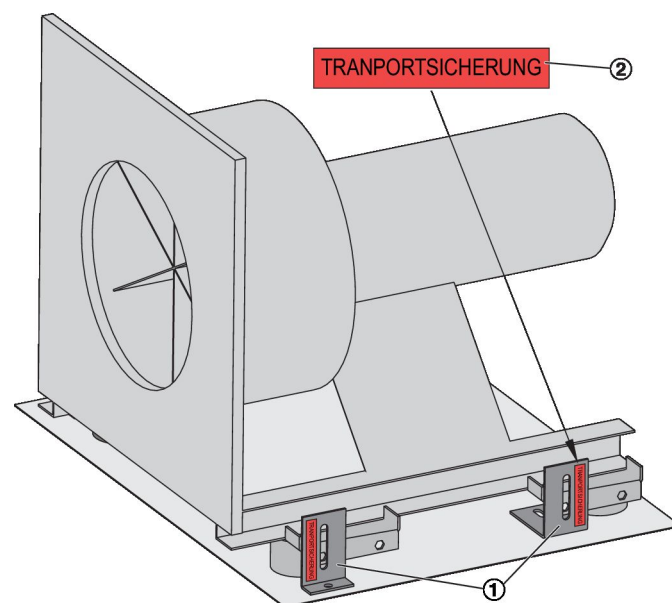

Fig. 10: Transport protection brackets

1. ▶ Remove the brackets (Fig. 10 /1) that are marked with a red sticker (Fig. 10 /2).
2. ▶ Then close the drilled holes in the floor of the AHU casing with screws and washers.

4 Setup and assembly

If an air handling unit is shipped in several parts, you have to erect and assemble it on site. The arrangement of the AHU casing units is given on the order-specific approval drawing.

Conformity assessment

If components or devices which cannot in themselves perform a specific application (partly completed machinery) are incorporated into fully functional machinery, the individual who performs the incorporation or assembly is responsible for the conformity assessment, for creating the declaration of conformity and for attaching the CE mark.

4.1 Safety notes

Setup and assembly

WARNING!

Risk to life from incorrect setup and assembly!

The incorrect setup and assembly of AHU casing units can lead to potentially fatal situations and cause considerable damage to property. Incorrect setup and assembly will also impair the function of the unit.

- Air handling units must only be set up and assembled by HVAC technicians.

Working at height

WARNING!

Risk of a fall when you work at height!

Working at height without using any fall protection equipment, or using unsuitable or damaged equipment to get up to where you work at height, may lead to yourself or others falling from height; people on the ground may be at risk from falling parts or tools. This can cause serious or even fatal injuries.

- Only use equipment that is suitable, stable and strong enough for the job, maintained and checked regularly.
- Stop materials or objects from falling.
- Wear safety shoes, protective clothing and a hard hat.
- Wear a safety harness.

Interconnecting units and systems

WARNING!

Risk of injury from interconnecting different units or systems!

Connecting an air handling unit to other units or systems (e.g. ductwork, pumps, refrigeration systems) can lead to dangerous situations and eventually cause serious or even fatal injuries.

- If you have to connect other units or systems to the air handling unit, connect them professionally.
- The system owner/HVAC contractor is responsible for the planning and installation of any additional safeguards.

Sharp edges, sharp corners and thin sheet metal parts

CAUTION!

Danger of injury from sharp edges, sharp corners and thin sheet metal parts!

Sharp edges, sharp corners and thin sheet metal parts of the heat exchanger or of the cooling or heating coil may cause cuts or grazes.

- Be careful when working on these components.
- Wear protective gloves, safety shoes and a hard hat.

Inspection access doors slamming shut

WARNING!

Risk of crushing from doors slamming shut

Inspection access doors may slam shut by the wind or if someone pushes them inadvertently, resulting in serious injury to the head and limbs.

- Secure each inspection access door with a hold open device.
- Secure inspection access doors without a hold open device against closing by suitable means.
- Do not reach between the door and door frame.
- Wear protective gloves and a hard hat when you open an inspection access door.

Crushing hazard! **WARNING!****Crushing hazard from movable parts!**

There is an increased risk of crushing on casing units, doors, panels and components of the device.

- Never reach between moving parts.
- Be careful when carrying out any work.
- Wear protective gloves, safety shoes and a hard hat.

Damage to inspection access doors **NOTICE!****Physical damage to inspection access doors**

Do not open inspection access doors which are hinged on one side if their width is ≥ 1000 mm or more!

The closures can be damaged due to the weight and the leverage forces that occur.

In the case of inspection access doors from a width of ≥ 1000 mm, always open all closures and remove the door from the air handling unit.

Store doors safely where they are protected against damage!

4.2 Requirements for the installation location **DANGER!****Risk of injury from an unsuitable installation location!**

Do not install the AHU in a location that can be accessed by everybody.

AHUs may have lockable doors, yet a risk of injury, vandalism, burglary etc. remains.

Install the AHU in a location that can only be accessed by authorised persons.

4.2.1 Requirements for indoor installation**Installation room**

Air handling units designed for indoor installation have to be installed in a room that meets the following requirements:

- The room has been designed in compliance with the applicable building regulations and is suitable for the technical systems to be installed. National standards for plant rooms may also apply.
- The installation room has to be

- clean
- dry
- free from conductive dust particles
- free from strong electromagnetic fields
- free from aggressive atmospheres
- free from frost
- fitted with a functioning drainage system
- There is sufficient clearance for installing, operating, servicing, and repairing the AHU and all its parts.
 - The maintenance access has to be at least as deep as the unit.
 - The maintenance access must be wide enough so that all inspection access doors can be opened with an opening angle of 90° .
- The structure on which the air handling unit is to be installed must be suitable for the weight and have a level surface (see the order-specific data sheet for the air handling unit).
- Do not use the air handling unit as a structural element or as a roof for a building.
- Do not use the air handling unit in potentially explosive atmospheres.

Escaping water **NOTICE!****Risk of damage to property from escaping water!**

If the water system is not tight, water may escape and cause considerable damage to property.

- Ensure that liquids are channelled away and to a collection device.

Installation room foundation

The installation room foundation must fulfil the following requirements:

- It is horizontal, flat and robust, made of concrete; alternatively, a support structure made of steel may be used.
- The frequency of the support structure, particularly of a steel structure, is sufficiently different from the excitation frequency of movable components, such as fans, motors, pumps or refrigerant condensers.
- For air handling units with a condensate drain, the support structure is at least as high as the drain trap, see  *Chapter 5.3 'Connecting the condensate drain' on page 35*.
- If additionally structure-borne noise is to be attenuated (e.g. by rubber or elastomer sheets underneath the air handling unit), be sure to exactly align all AHU casing units (check for door closure, properly sealed joints).

4.2.2 Requirements for outdoor installation

Installation location

For outdoor installation please note:

- Do not use the air handling unit in potentially explosive atmospheres.
- The installation location has to be
 - free from conductive dust particles
 - free from strong electromagnetic fields
 - free from aggressive atmospheres
 - fitted with a functioning drainage system
- The structure on which the air handling unit is to be installed must be suitable for the weight and have a level surface (see the order-specific data sheet for the air handling unit).
- There is sufficient clearance for installing, operating, servicing, and repairing the AHU and all its parts. The maintenance access has to be at least as deep as the unit.
- Make sure that the installation location meets local regulations to prevent the fall of people, and of tools and other objects.
- Use suitable fall arrest equipment.
- Prevent unauthorised individuals from accessing AHU casing units.
- Make sure that authorised individuals can access AHU casing units safely.
- Keep the structural properties in mind and make sure the maximum roof load is not exceeded; do not neglect the effects of weather on the unit (rain, snow, wind, sun etc.).
- The stability of the device at the installation site must be ensured; we recommend that proof of stability with regard to wind load and other external influences be provided, e.g., by means of a wind load calculation. Depending on the expected wind load, the device must be fixed to the foundation/support structure or braced with suitable components.
- Only a skilled qualified professional must connect the air handling unit to an external switch cabinet and prevent the cables from the effects of weather (rain, snow, wind, sun etc.).
- All heat transfer fluid pipes and hoses and the AHU components to which they are connected must be frost-proof.
- Do not use the air handling unit as a structural element or as a roof for a building.

Foundation of the outdoor installation area

- The information regarding the foundation of the installation room applies, ↪ *'Installation room foundation'* on page 21
- For roof installation, check the load capacity and support structure of the roof; consult a structural engineer if necessary.
- The entire air handling unit must be supported by a continuous steel structure.

- The beams of the steel support structure must be designed for a maximum deflection of $L/500$ (L = beam length). A maximum deflection of 10 mm under load must not be exceeded.
- Waterproof the edge of the roof under the AHU and also any connections penetrating the roof (on site).
- Insulate the one-site base frame to prevent condensation.
- In areas with heavy snowfall, choose an installation location where snow will not affect the operation of the AHU. Select the height of the support structure accordingly.

Escaping water

! NOTICE!

Risk of damage to property from escaping water!

If the water system is not tight, water may escape and cause considerable damage to property.

- Ensure that liquids are channelled away and to a collection device.

4.3 Preventing vibration and structure-borne noise

If the AHU is equipped with an anti-vibration base frame (AVBF, optional), no additional measures are required for the insulation of structure-borne noise.

For AHUs without anti-vibration frames, vibration and structure-borne sound insulating underlays can be used to reduce the transmission of vibrations to the support structure:

- For installation on level ground with no special requirements regarding insulation of structure-borne noise, we recommend decoupling the foundation from the AHU, for example using rubber or elastomer sheets.
- For noise insulation, compare the requirement to the sound power level of the AHU (see order-specific data sheet for the AHU) and have the necessary measures determined by an acoustics engineer.
- Use splitter sound attenuators if necessary.

! NOTICE!**Risk of damage to the AHU**

Anti-vibration elements or a noise insulating layer must not affect the structural safety of the AHU. Ensure the following:

- Use a sufficient number of anti-vibration elements and noise insulating layers and place them correctly as otherwise the frame may sag.
- Keep in mind that the various AHU casing units differ in weight; this must not lead to any height differences in the overall unit.

We recommend you to have noise insulating layers (including material and layout plan) selected and sized by an expert company.

4.4 Setting up and assembling the AHU**i Disassembly for transport**

If the entire device is too large for transport to the installation site, it can be disassembled at the separation points. The separation points can be seen on the screw connections of the base frames (Fig. 16 /A). The disassembly of the AHU into individual components is carried out in reverse order to the assembly description ↪ Chapter 4.4.2 'Assembling AHU casing units' on page 25 .

When disassembling, disconnect the plug connections of the lines and pull them back into the individual component for transport, ↪ Chapter 5.6 'Wiring' on page 40 . Loosen the hoses of the differential pressure control at the connection points.

Personnel:

- HVAC technician

Protective equipment:

- Industrial safety helmet
- Hearing protection
- Protective gloves
- Safety shoes
- Safety harness

! NOTICE!**Risk of damage to property from incorrect assembly!**

Be sure to assemble the AHU casing units correctly as otherwise the condensate drain may be damaged.

- Protect the condensate drain from damage.

4.4.1 Setting up the AHU or AHU casing units**4.4.1.1 Setting up the AHU or AHU casing units****i Arrangement of AHU casing units**

The arrangement of the AHU casing units is shown in the drawings that come with the casing units.

i Installation accessories

All installation accessories come in a package that is usually found in the fan chamber.

1. ▶ At the installation location: Move the AHU casing units as close together as possible and according to the correct assembly sequence, Fig. 11 . Make sure that all the connections (e.g. water) are on the correct side.
2. ▶ Remove all the plastic wrapping.

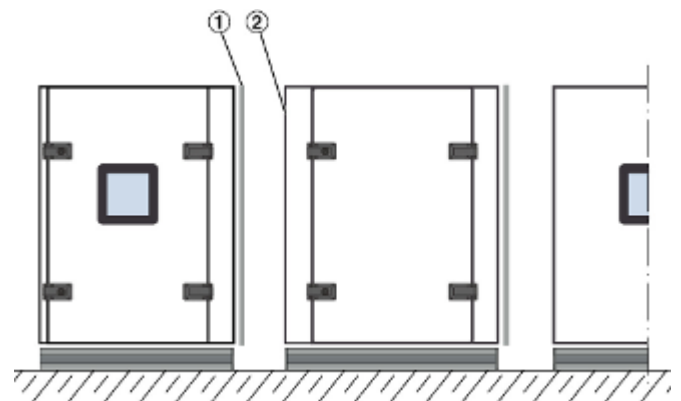

Fig. 11: Seals on AHU casing units

3. ▶ AHU casing units that are to be joined are fitted with perimeter seals (Fig. 11 /1). Note that only one of each two casing units that are to be joined has a seal; the other one does not have a seal (Fig. 11 /2).

Check that the seals are complete and intact and that they seal properly.

i Compressed (deformed) seals

Compressed seals will recover fully to their original state about 60 minutes after the transport protection devices have been removed.

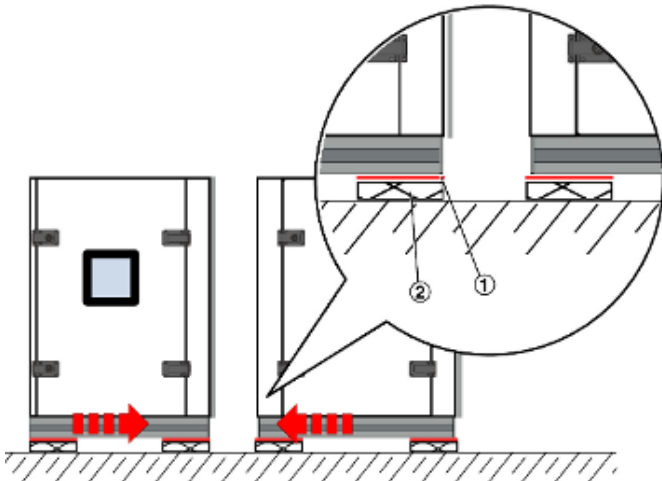

Fig. 12: Slide plates simplify the positioning of AHU units

4. ▶

AHUs with anti-vibration base frame (optional)

If the air handling unit is equipped with an anti-vibration base frame (AVBF, optional), no additional measures are required for the insulation of structure-borne noise, and this installation step can be omitted.

Slide plates considerably simplify the process of positioning the AHU on a surface with a high friction coefficient, such as rubber rubber or elastomer sheets.

Place the slide plates (Fig. 12 /1) between the base frame and the floor (Fig. 12 /2).

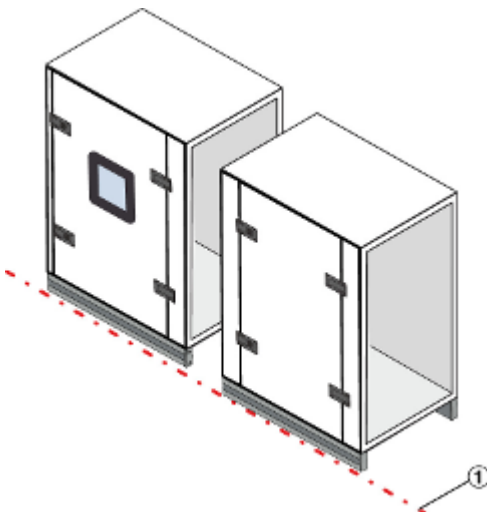

Fig. 13: Aligning AHU casing units

5. ▶ Align the AHU casing units so that they are flush with one another (Fig. 13 /1).

AHUs with X-CUBE Control:

6. ▶ Before you push the AHU casing units together, insert the internal cables of each unit into the cable ducts of the next casing unit; for more information see Chapter 5.6 'Wiring' on page 40 .

Units with base frame

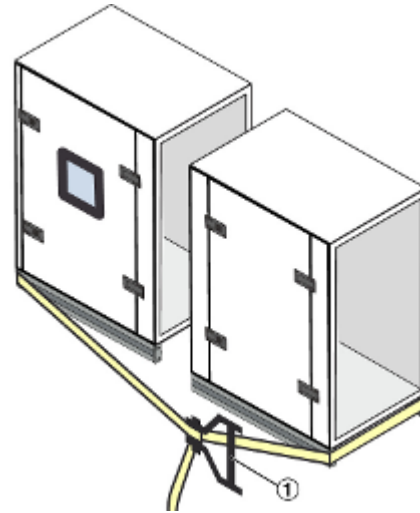

Fig. 14: Attaching a ratchet strap to units with base frame

7. ▶ Attach a ratchet strap to the base frames of two AHU casing units (Fig. 14).

Tighten the ratchet strap.

⇒ The AHU casing units come closer together as you tighten the strap around the base frames.

Units without base frame

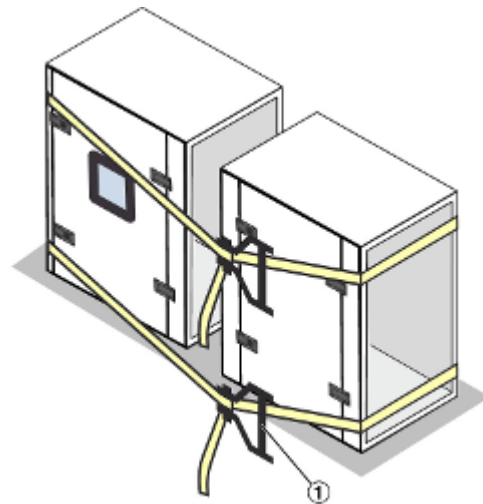

Fig. 15: Attaching ratchet straps to units without base frame

8. ▶ Attach one ratchet strap each at the top and bottom of two AHU casing units.

9. ▶ Tighten the ratchet straps alternately.

⇒ The AHU casing units come closer together as you tighten the strap.

4.4.2 Assembling AHU casing units

Joining AHU casing units with screws/bolts

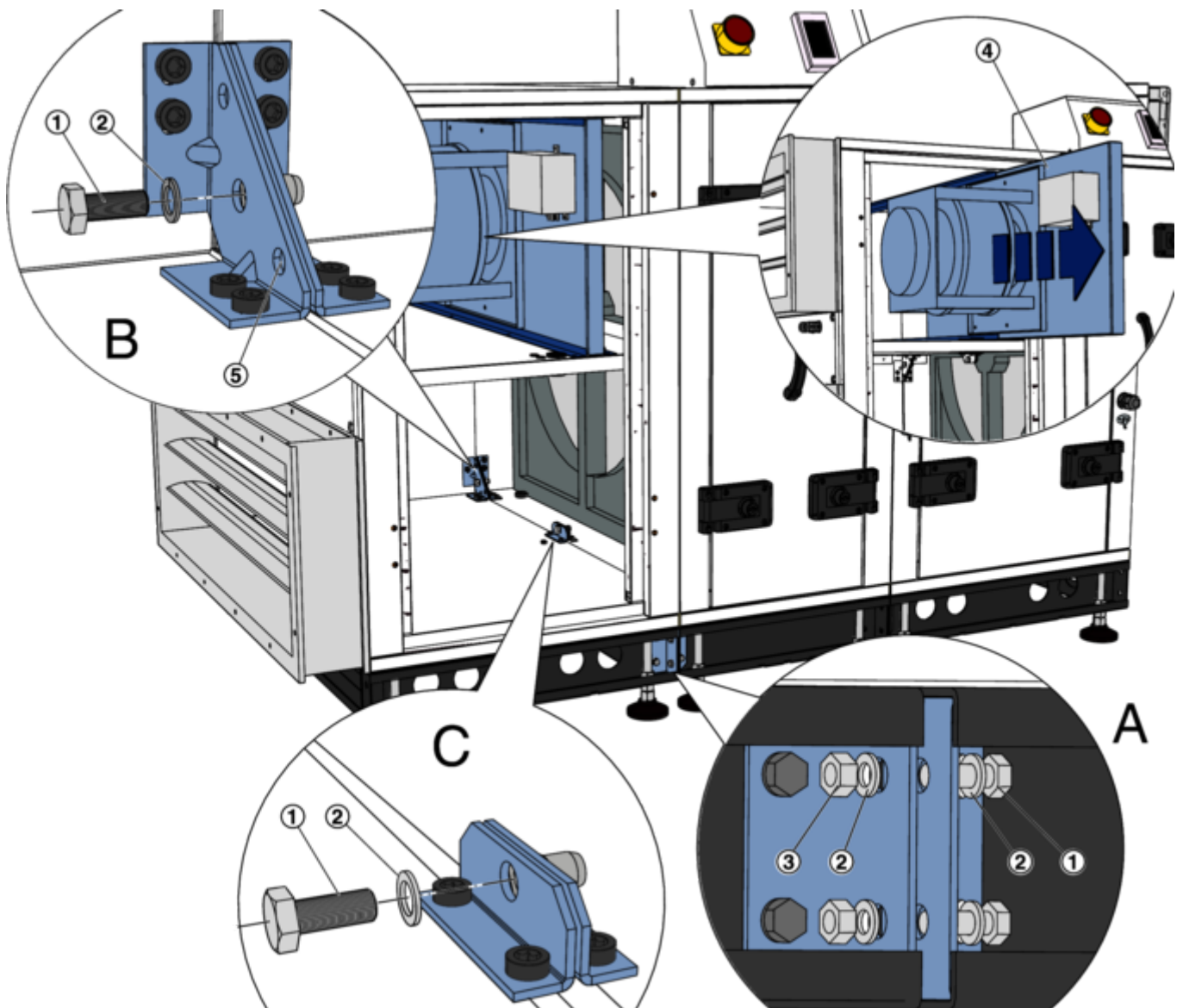

Fig. 16: Connecting AHU casing units

- | | |
|--------------------------|---|
| 1 Hexagon head screw M10 | 4 Fan mounting plate (can be pulled out for sizes R/P015 to R/P050) |
| 2 Washer M10 | 5 Centring aid for mounting iron |
| 3 Nut M10 | |

- ▶ Screw the AHU casing units together evenly at the following points (screws included in the supply package):
 - End faces of the base frames (Fig. 16 /A)
 - Gusset plates, in each corner (Fig. 16 /B)
 - Bracket (Fig. 16 /C)

Screw attachment of the AHU casing units to the fan

- Size R/P015 to R/P050 - To reach the connection points, pull out the fan mounting plate completely (Fig. 16 /4). Before pulling out, disconnect all necessary cables at the plug connections!
- Size R/P070 bis R150 - The adjacent components are bolted to the fan mounting plate. For better accessibility of the connection points, the fan can be disassembled from the fan mounting plate by loosening the screw connections. Before disassembly, disconnect all necessary cables at the plug connections!

2. ▶ If accessory modules are included in the supply package, they can be mounted afterwards, ↪ 4.4.4 'Installing accessories' on page 30.

Connecting the Modbus line of the device

3. ▶ Connect the withdrawn Modbus lines (RJ12) between FAN IO (on the respective fan) and X-CUBE control master (switch cabinet). ↪ Chapter 5.6.1 'Connections and interfaces' on page 42

Attaching the connecting subframe

If connecting subframes have been supplied separately, install them once the AHU units have been set up and assembled. Depending on the AHU construction variant, the connecting subframe has to be attached either to the AHU itself (panel) or to a multileaf damper.

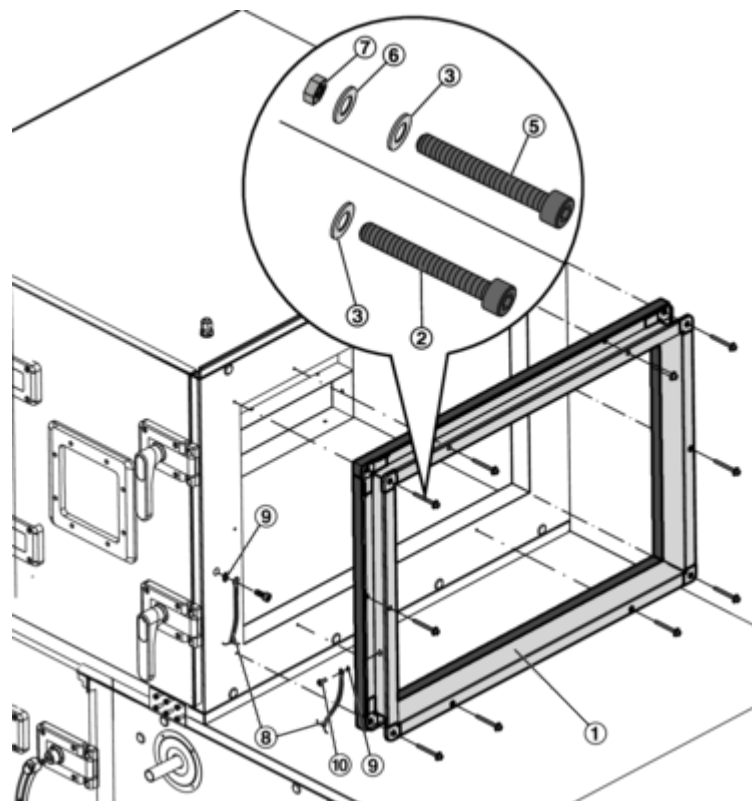

Fig. 17: Attaching the connecting subframe

Supplied assembly material

Pos.	Designation	Part no.			
		Panel		Multileaf damper	
		Galvanised steel	Stainless steel	Galvanised steel	Stainless steel
①	Spigot				
②	Thread forming socket cap head screw M6 × 40	A00000055910	A00000055911	–	–
③	Washer Ød 6.4	M332AA3	M333AA3	M332AA3	M333AA3
⑤	Socket cap head screw M6 × 40	–	–	A00000018868	A00000056190
⑥	Washer Ød 6.4	–	–	M332AF9	M333AC3
⑦	Nut M6	–	–	M332AD6	M323AA3
⑧	Earthing cable	A00000026651			
⑨	Lock washer, serrated	M332KB4	A00000045194	M332KB4	A00000045194
⑩	Pan head screw M6 × 12	M852AC6			
⑪	Socket cap head screw M6 × 30	M852AC4			

- ▶ Place the connecting subframe (Fig. 17 /1) with the perimeter seal facing the AHU and fix it with thread forming screws (Fig. 17 /2), rubber seals (Fig. 17 /4) and washers (Fig. 17 /3).

i **Attaching the connecting subframe to a multileaf damper**

If the connecting subframe is to be attached to a multileaf damper, fix it with the supplied socket cap screws (Fig. 17 /5), washers (Fig. 17 /3 and 6) and nuts (Fig. 17 /7).

- ▶ Fix one eye of the earth cable (Fig. 17 /8) with a pan head screw M6 × 12 (Fig. 17 /10) and a serrated lock washer (Fig. 17 /9) to the noise insulating connector.

! NOTICE!

Electrical conductivity

For electrical conductivity the serrated lock washer needs to be fitted between the eye of the earth cable and the coated surface.

- ▶ Fix the other eye of the earth cable with a socket cap head screw M6 × 30 (Fig. 17 /11) and a serrated lock washer through the panel sheet to the tubular frame of the air handling unit.

4.4.3 Additional assembly steps for outdoor units

Connecting the roof segments

Air handling units for outdoor installation require the following additional assembly steps:

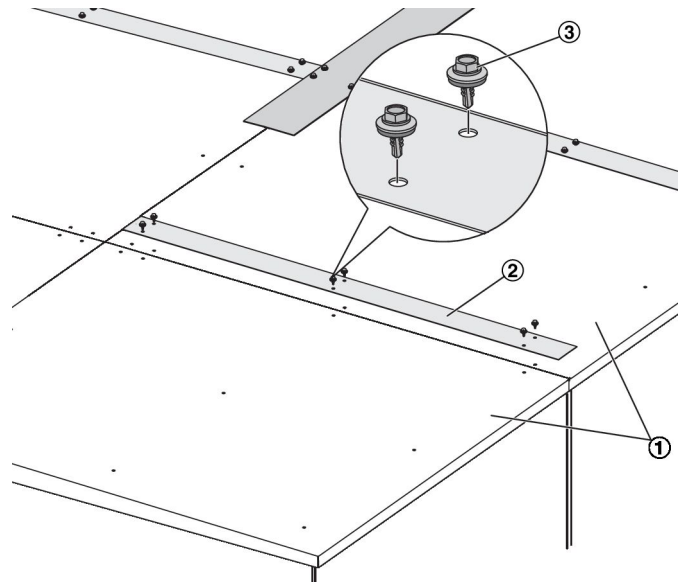

Fig. 18: Joining roof segments

- ① Roof segments
- ② Cover strips
- ③ Self-drilling screws with sealing washers
- ④

- ▶ Connect all joints between the roof segments (Fig. 18 /1) with cover rails (Fig. 18 /3), and fix cover rails with drilling screws (Fig. 18 /4).

! NOTICE!

Remove the eye nuts where the casing units are to be joined so that you can actually join the roof segments. Do not remove the other eye nuts; they have to remain in place to prevent the ingress of rain into the unit.

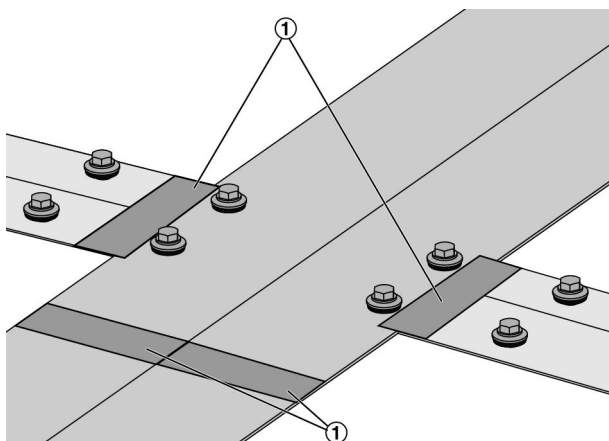

Fig. 19: Sealing the joints

2. ▶ Seal the joints (Fig. 19 /1) between the cover strips with the supplied adhesive strips (100 x 40 mm).

Make sure that all surfaces are clean, free from grease, and dry. Clean the surfaces, if necessary.

Stacked units (step design)

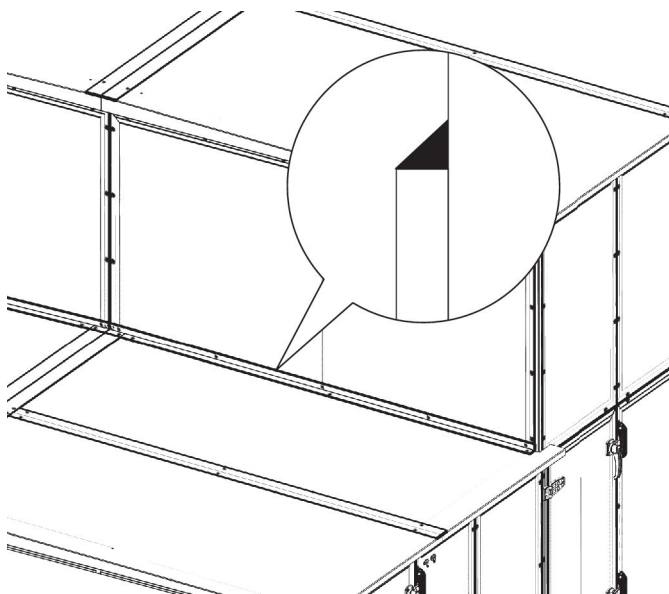

Fig. 20: Step design

3. ▶ Fix the connecting angle section for the roof segment with self-drilling screws and seal it with sealant.

Installing ducts

Personnel:

- HVAC technician

Protective equipment:

- Industrial safety helmet
- Protective clothing
- Protective gloves
- Safety shoes

1. ▶ Ensure precise fit and avoid distortion when you connect the ducts.

Note: Any load on the noise insulating connector may impair the tight fit. Connect the duct in such a way that no loads are imposed on the connector; if necessary, slightly retighten the screws on the connector.

2. ▶ Insulate ducts (including flexible connectors and connecting frames).
3. ▶ For outdoor units: Protect ducts (including spigots and connecting frames) against the effects of weather.

4.4.4 Installing accessories

Attaching an accessory module to the air handling unit

Personnel:

- HVAC technician

Protective equipment:

- Industrial safety helmet
- Protective clothing
- Hearing protection
- Safety shoes
- Protective gloves

Proceed as follows to attach an accessory module to the air handling unit:

i Separate installation locations for accessory modules

If an accessory module was ordered with the air handling unit, the supply air spigot has been factory mounted on the supply air side of the accessory module.

If space at the installation site is too tight, the AHU and accessory module can be installed separately and connected with a rectangular duct. The connection requires two additional device-specific spigots, each of which must be mounted on the AHU and the accessory module.

1. ▶ Position the accessory module in such a way that the holes of the fixing points are flush (Fig. 21).

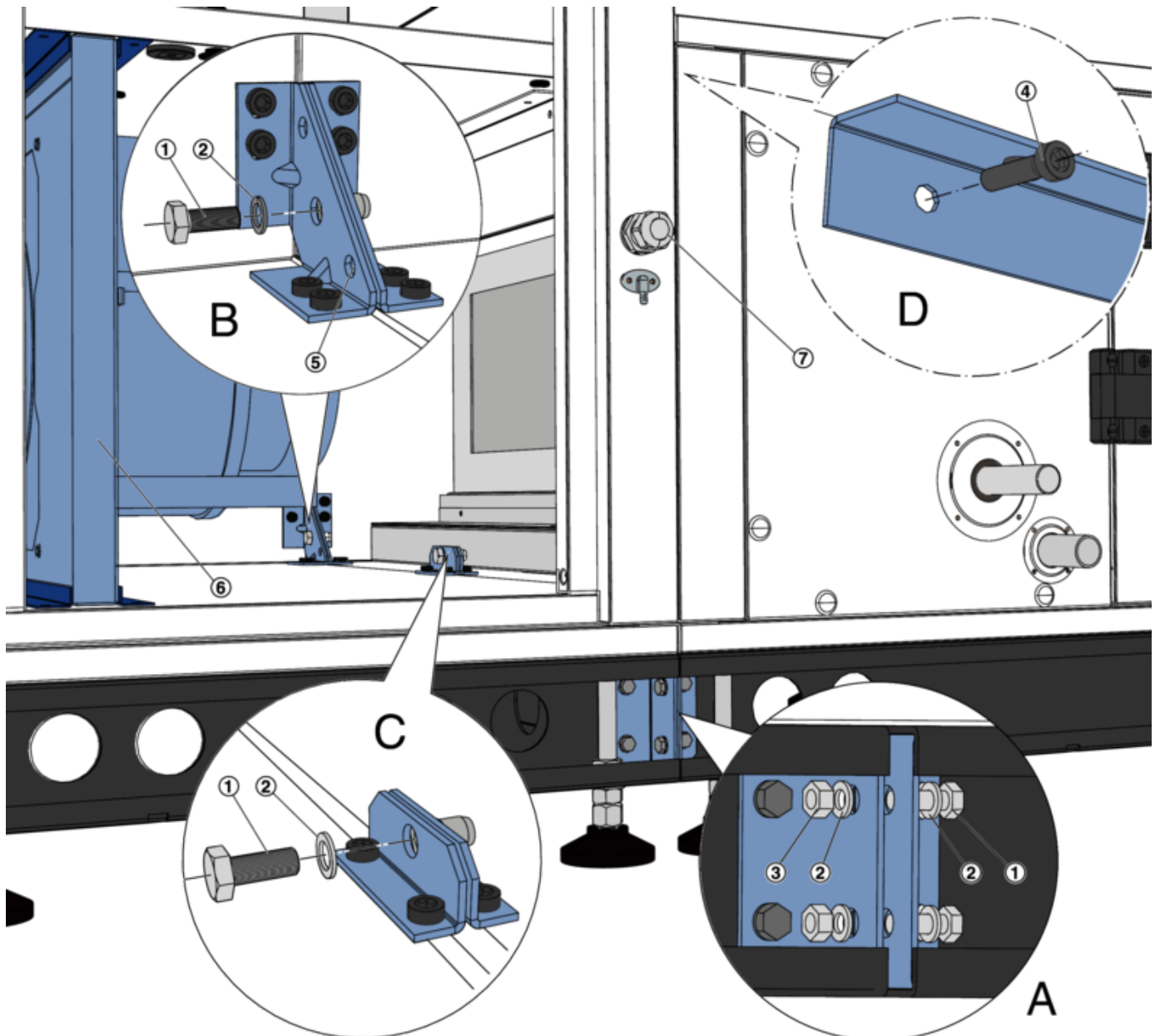

Fig. 21: Attaching the accessory module to the device

- | | |
|--------------------------|--|
| 1 Hexagon head screw M10 | 5 Centring aid for mounting iron |
| 2 Washer M10 | 6 Fan mounting plate (can be pulled out for sizes R/P015 to R/P050) |
| 3 Nut M10 | 7 Cable gland for accessory module |
| 4 Cheese head screw M6 | |

2. ▶ Screw the AHU and accessory module together evenly at the following points (screws included in the supply package):
 - End faces of the base frames (Fig. 21 /A)
 - Gusset plates, in each corner (Fig. 21 /B)
 - Bracket (Fig. 21 /C)
 - Bracket (Fig. 21 /D)

Screw attachment of the AHU casing units to the fan

Size R/P015 to R/P050 - For better accessibility of the connection points, the fan mounting plate (Fig. 21 /6) can be pulled out completely.
Before pulling out, disconnect all necessary cables at the plug connections!

Size R/P070 bis R150 - For better accessibility of the connection points, the fan can be disassembled from the fan mounting plate by loosening the screw connections.
Before disassembly, disconnect all necessary cables at the plug connections!

3. ▶ Connect the accessory module to the earth; use the hexagon head screw (Fig. 21 /1) on the lower gusset plate on the operating side for this purpose.



Fig. 22: Earth symbol sticker

4. ▶ Affix the earth symbol sticker (Fig. 22) next to the earthed gusset plate.

Connecting the accessory module

5. ▶



WARNING!

Risk to life from incorrect installation!

Incorrect installation can lead to potentially fatal situations and cause considerable damage to property.

- Only a skilled qualified electrician must connect the power supply.
- Any other installation job has to be carried out by an HVAC technician.

For the accessory module, connect the field devices (e.g., pumps, valves, sensors) to the extension module (terminal X2); see the enclosed wiring diagram. Insert all electrical cables into the casing via the cable gland of the device ↪ 'Cable gland on the X-CUBE Compact 2' on page 52 .

To set the Modbus address of the accessory module, see ↪ Chapter 5.10 'Setting the bus address for accessories' on page 53 , and to activate the accessories, see ↪ Chapter 6.4.2 'Activating accessories' on page 61

Connecting the duct temperature sensor for supply air

6. ▶ Connect the duct temperature sensor for supply air to the extension module (terminal X2); see the attached wiring diagram. Insert all electrical cables into the casing via the cable gland of the device ↪ 'Cable gland on the X-CUBE Compact 2' on page 52 .

4.5 Mounting levelling feet

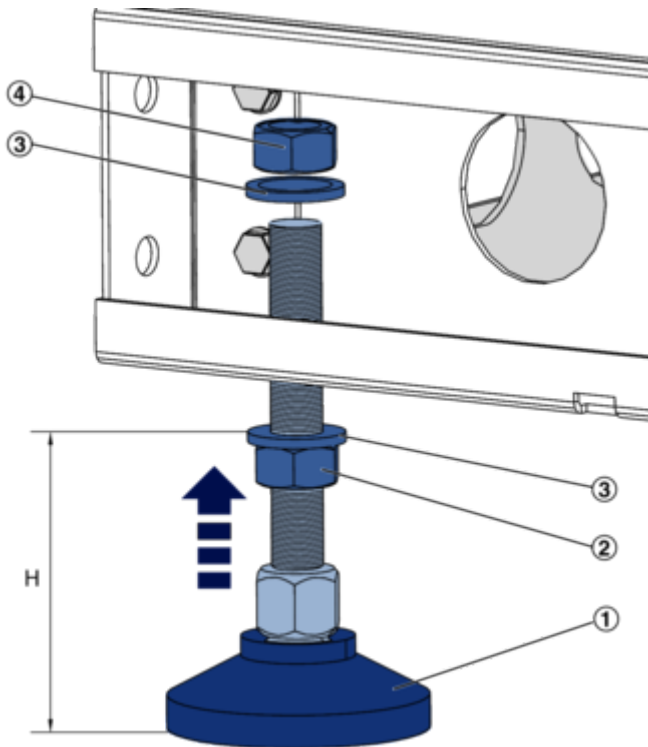

Fig. 23: Mounting a levelling foot

- 1 Levelling foot
- 2 Nut
- 3 Washers
- 4 Lock nut
- H 60 – 120 mm

For subsequent assembly, the device must be lifted with a lift truck, crane or similar equipment.

1. ▶ Adjust the height (H) on the levelling feet with the screw and washer.
2. ▶ Insert the levelling feet from below into the holes on the base frame.
3. ▶ Screw on the nut and washer.
4. ▶ Then set the device down and align it using the screws.
5. ▶ Tighten the locknuts.

5 Installation

5.1 Safety notes regarding installation

Incorrect installation

 **WARNING!**

Risk to life from incorrect installation!

Incorrect installation can lead to potentially fatal situations and cause considerable damage to property.

- Only a skilled qualified electrician must connect the power supply.
- Any other installation job has to be carried out by an HVAC technician.

Inspection access doors slamming shut

 **WARNING!**

Risk of crushing from doors slamming shut

Inspection access doors may slam shut by the wind or if someone pushes them inadvertently, resulting in serious injury to the head and limbs.

- Secure each inspection access door with a hold open device.
- Secure inspection access doors without a hold open device against closing by suitable means.
- Do not reach between the door and door frame.
- Wear protective gloves and a hard hat when you open an inspection access door.

Crushing hazard!

 **WARNING!**

Crushing hazard from movable parts!

There is an increased risk of crushing on casing units, doors, panels and components of the device.

- Never reach between moving parts.
- Be careful when carrying out any work.
- Wear protective gloves, safety shoes and a hard hat.

Hot surfaces

 **WARNING!**

Risk of injury from hot surfaces!

The surfaces of components can get very hot during operation. Skin contact with hot surfaces causes severe skin burns.

- Professionally insulate pipes that connect condensers or heating coils.

Interconnecting units and systems

 **WARNING!**

Risk of injury from interconnecting different units or systems!

Connecting an air handling unit to other units or systems (e.g. ductwork, pumps, refrigeration systems) can lead to dangerous situations and eventually cause serious or even fatal injuries.

- If you have to connect other units or systems to the air handling unit, connect them professionally.
- The system owner/HVAC contractor is responsible for the planning and installation of any additional safeguards.

Sharp edges, sharp corners and thin sheet metal parts

 **CAUTION!**

Danger of injury from sharp edges, sharp corners and thin sheet metal parts!

Sharp edges, sharp corners and thin sheet metal parts of the heat exchanger or of the cooling or heating coil may cause cuts or grazes.

- Be careful when working on these components.
- Wear protective gloves, safety shoes and a hard hat.

5.2 Before installation

Before installation

- Have all the applicable documents at hand,
 - ↳ 'Other applicable documentation' on page 3
- Ensure that the installation requirements are met, see the order-specific data sheet for the air handling unit.
- Have all the required tools ready.

5.3 Connecting the condensate drain

Electric current

⚠ WARNING!

Danger of death due to electric current!

If electrical components come into contact with water, e.g. from a leak, you could be seriously or even fatally injured. Water can also cause damage to the air handling unit.

- Lay drainage pipes in such a way that they cannot be accidentally damaged by mechanical impact or by heat.

Calculate height of drain trap

! NOTICE!

Risk of leakages due to incorrect installation!

Do not connect the condensate drain to the sewerage system without a drain trap or with an unsuitable drain trap as this may result in air getting into the AHU.

- Use a suitable drain trap to connect the AHU to the sewerage system.
- Do not connect the siphon directly to the waste water network, the siphon must be able to drain freely.
- Use a different drain trap for each condensate drain. Do not connect condensate drains with each other.
- A gap must be left between the drain trap on the negative pressure side and the floor.

Calculate the height of a drain trap as shown below.

Symbol:

- P - Pressure inside the AHU [Pa]; be sure to use a positive value for calculations. Take the final pressure loss (filter etc.) into consideration
- 1.5 - Safety factor to compensate for pressure fluctuations, e.g. due to fast-closing dampers (only for positive pressure)
- R - Distance R [mm]; minimum distance between condensate drain (centre line) and floor on the positive pressure side
- X + 60 - Distance X + 60 [mm]; minimum distance between condensate drain (centre line) and floor on the negative pressure side
- H - Distance H [mm]; minimum distance between lower edge of base frame and floor
- A - Distance A [mm]; distance between lower edge of base frame and condensate drain (centre line). Depends on the base frame (GR), see table

Negative pressure (extract air)

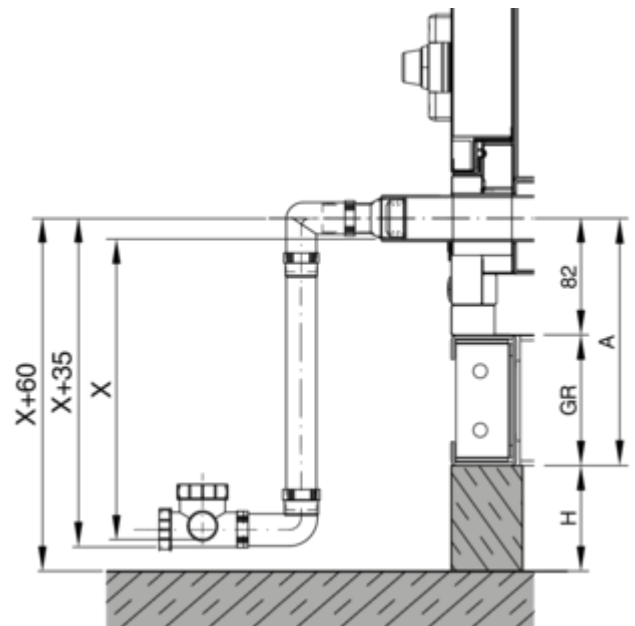

Fig. 24: Drain trap for negative pressure in the unit

Calculation to be used for negative pressure (2900 Pa max.):

- $X = P / 10$
- $H = X + 60 - A$

Base frame construction	Acoustic decoupling	GR [mm]	A [mm]
110	without	110	192
	with	135	217

Calculation example

Given data:

P - 1800 Pa

GR - 110 mm

A - 192 mm

$X = 1800 \text{ Pa} / 10 = 180 \text{ mm}$

$H = 180 + 60 - 192 \text{ mm} = 48 \text{ mm}$

If the calculation value is negative, no additional installation height H is required.

Positive pressure (supply air)

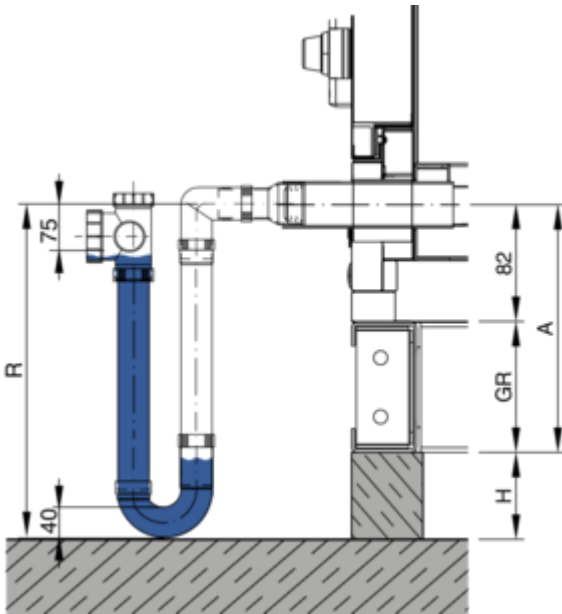

Fig. 25: Drain trap for positive pressure in the unit

Calculation to be used for positive pressure (1630 Pa max.):

- $R = P \times 1.5 / 10 + 115 (40 + 75)$
 $H = R - A$
- Always cut or extend immersion tubes evenly (same length). Do not cut a pipe by more than 155 mm.; R has to be at least 215 mm.

Calculation example

Given data:

P - 1500 Pa

GR - 110

A - 192

$R = 1500 \text{ Pa} \times 1.5 / 10 + 115 \text{ mm} = \underline{340 \text{ mm}}$

$H = 340 - 192 = \underline{148 \text{ mm}}$

Connecting a drain trap

Personnel:

- HVAC technician

Protective equipment:

- Industrial safety helmet
- Protective clothing
- Protective gloves
- Safety shoes

! NOTICE!

Risk of damage to property from incorrect pipe connections!

Improper connection can damage the connection pipes and the drain trap to the point of destruction.

- Make sure that that no forces or vibrations act through the on-site connection.
- If an AHU is installed outdoors, use suitable pipes and protect them from frost.

Drain trap connection dimensions

Outer diameter of drainage pipe - 40 mm

1. ▶ Calculate the height of the drain trap as shown above.

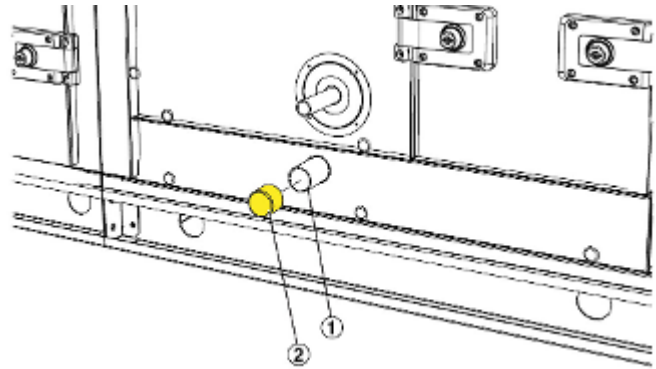

Fig. 26: Condensate drain

2. ▶ Remove the protective cap(s) (Fig. 26 /2) from the drain (Fig. 26 /1) of the condensate drip tray.

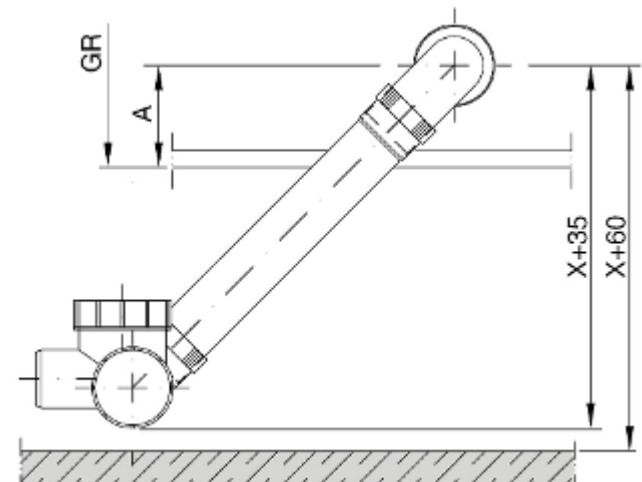

Fig. 27: Sloped pipe of a drain trap for negative pressure

3. ▶ Adjust the height of the drain tap based on the above calculation. Drain traps for negative pressure: Instead of shortening the immersion tube, install the drain trap in a sloping position.

4. ▶ Connect a drain trap to each condensate drain (Fig. 26 /1).

Do not connect the drain trap directly to the sewer; the drain trap must be able to drain freely.

Air handling units to be installed outdoors or in areas at risk of frost require frost protection for the drain trap.

5.4 ☒ Connecting the heating coil/cooling coil

Electric current

⚠ WARNING!

Danger of death due to electric current!

If electrical components come into contact with water or a water glycol mixture, e.g. from a leak, you could be seriously or even fatally injured. Water can also cause damage to the air handling unit.

- Lay connecting cables in such a way that they cannot be accidentally damaged by mechanical impact or by heat.
- Do not lay connecting cables across electrical components or switch cabinets as people may become entangled in them.



Stickers on the connection side of the heat exchangers indicate the flow (Fig. 28 /IN) and return connections (Fig. 28 /OUT) for a counter flow arrangement.

In special constructions of the heat exchanger, these stickers may not show the correct type of connection. The heat exchangers must always be connected in a counter flow arrangement. For questions on the connections, please contact the unit manufacturer.

Connect slide-out heat exchangers and droplet eliminators with bends and detachable connections as otherwise you will not be able to withdraw them.

Connect heat exchangers in a counter flow arrangement unless a parallel flow arrangement has been specified by the manufacturer. Only a counter flow arrangement ensures that the calculated capacity is achieved.



If you have to attach brackets or fasteners to the AHU panels or frame, use only those specially approved for your AHU as otherwise there is a risk of leakages.

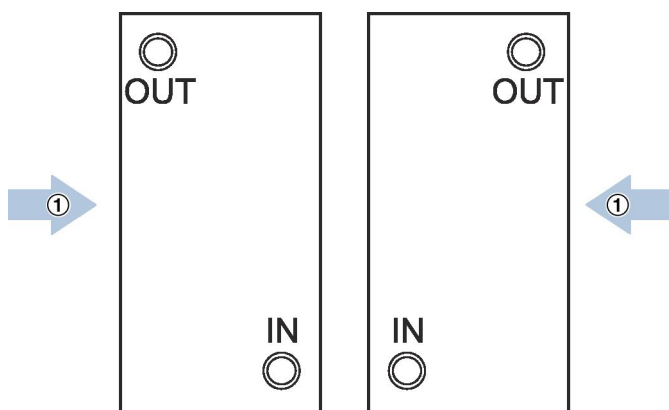

Fig. 28: Exemplary illustration of the heat exchanger connections in a counter flow arrangement

1 Airflow direction

Connecting the heating coil/cooling coil

Personnel:

- HVAC technician

Protective equipment:

- Industrial safety helmet
- Hearing protection
- Protective clothing
- Protective gloves
- Safety shoes

! NOTICE!

Risk of damage to property from incorrect pipe connections!

Take care to connect the heat exchanger pipes correctly as otherwise the pipes may twist or become subject to adverse effects. This may eventually damage the heat exchanger beyond repair.

- Connect pipes in such a way that the heat exchanger is not affected by vibration and that no loads are imposed on it.
- If there is too much weight on a water pipe (by others), support the water pipe.
- Do not use the connection point of the heat exchanger as a fixing point for other parts.
- When you tighten thread connections, be sure to use a suitable tool (e.g. water pump pliers) to counter the tightening force as otherwise you may inadvertently damage the parts.
- If an AHU is installed outdoors, use suitable pipes and protect them from frost.
- Ensure that no air gets trapped in the pipes.

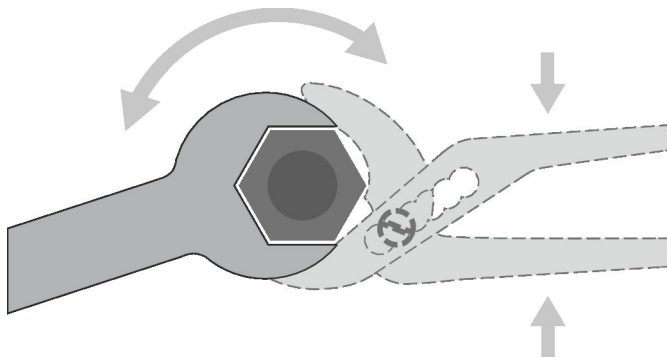

Fig. 29: Using water pump pliers to counter the tightening force

1. ▶ Hold the threaded pipe tail of the heat exchanger with water pump pliers (Fig. 29 /2).
2. ▶ Hold the threaded pipe tail with the pliers while you use a spanner (hexagonal profile, Fig. 29 /1) to connect the heat exchanger to the pipework (pipework by others).

Ventilation device

For optimum ventilation of the heat exchanger, we recommend that you install suitable air separators at the highest points of the system (e.g., above the air handling unit), which reduce the airflow velocity by increasing the cross section and can thus be ideally used for deaerating glycol systems.

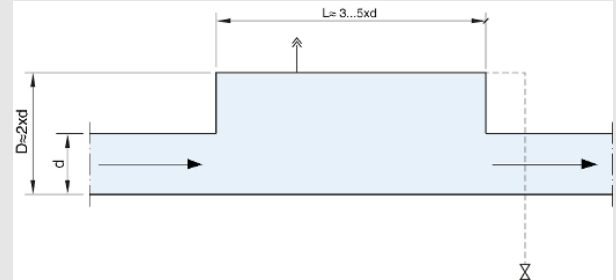

Fig. 30: Air separator with cross section enlargement

Installing the frost protection sensors

Observe the following points for installing the frost protection sensor (if present):

- Install the frost protection sensors into the return connection.
- When connecting, fix the threaded connection on the heat exchanger with a pipe spanner (Fig. 29 /2).
- To safeguard the frost protection function, permanent circulation in the heat exchanger must be ensured at low outdoor temperatures; this can be guaranteed, for example, by a secondary pump with a non-return valve.

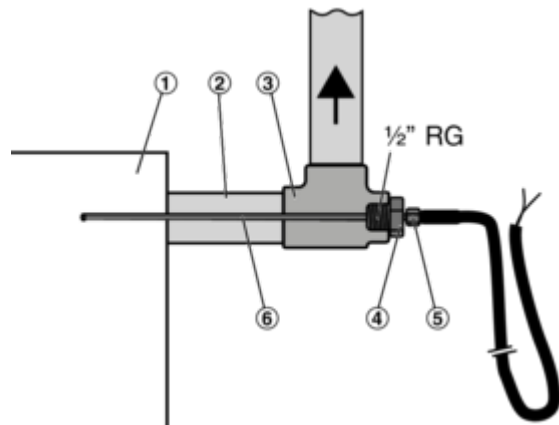

Fig. 31: Connecting the frost protection sensor

- 1 Heat exchanger
- 2 Heat exchanger return connection
- 3 T-piece with 1/2" connection (to be provided by others)
- 4 Frost protection sensor (supply package)
- 5 Spacer nut for setting the insertion depth
- 6 Measuring probe

5.5 Connecting the steam heat exchanger

Hot surfaces

WARNING!

Risk of injury from hot surfaces!

Steam heat exchangers are operated at temperatures of >100 °C. Skin contact with the heat exchanger causes severe skin burns.

Before you start working on the heat exchanger, shut off the steam supply and make sure that all surfaces have cooled down to ambient temperature, e.g. with an infrared thermometer.

DANGER!

Risk of injury due to escaping steam

If steam escapes due to a leak, immediately shut off the steam supply to the heat exchanger.

Before you start any repair work, completely drain the heat exchanger. This system contains steam at high pressure. If steam escapes due to a leak, it can cause severe scalds.

Connect steam heat exchangers in a counter flow arrangement unless a parallel flow arrangement has been specified by the manufacturer. Only a counter flow arrangement ensures that the calculated capacity is achieved.



If you have to attach brackets or fasteners to the AHU panels or frame, use only those specially approved for your AHU as otherwise there is a risk of leakages.

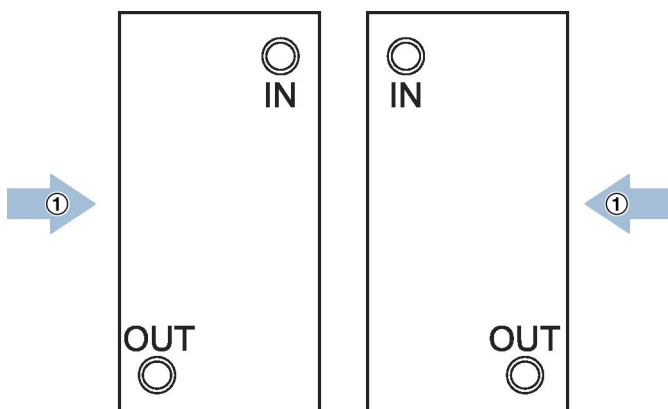

Fig. 32: Steam heat exchanger connections in a counter flow arrangement (example)

1 Airflow direction



Stickers on the connection side of the heat exchangers indicate the flow (Fig. 32 /IN) and return connections (Fig. 32 /OUT) for a counter flow arrangement.

For special heat exchanger constructions, however, the stickers may not show the correct type of connection. Heat exchangers must always be connected in a counter flow arrangement.

An additional requirement for steam heat exchangers is that the return connection has to be at the bottom so that any condensate can be safely discharged. If you have any questions regarding the connections, please contact the manufacturer.

Personnel:

- HVAC technician

Protective equipment:

- Industrial safety helmet
- Hearing protection
- Protective clothing
- Protective gloves
- Safety shoes

NOTICE!

Risk of damage to property from incorrect pipe connections!



Take care to connect the heat exchanger pipes correctly as otherwise the pipes may twist or become subject to adverse effects. This may eventually damage the heat exchanger beyond repair.

- Connect pipes in such a way that the heat exchanger is not affected by vibration and that no loads are imposed on it.
- If there is too much weight on a water pipe (by others), support the water pipe.
- Do not use the connection point of the heat exchanger as a fixing point for other parts.
- If an AHU is installed outdoors, use suitable pipes and protect them from frost.

5.6 Wiring

Air handling units with X-CUBE Control are factory wired. The functions of all electronic parts, sensors, actuators, etc. are tested before shipment. If a unit has to be disassembled into AHU casing units for shipment or for moving to the final installation location, the cables are disconnected at suitable interfaces and either pushed back into the cable ducts or rolled up. The wiring is shown in the wiring diagram (see the switch cabinet).

Interface connections

Component	Connection	Activity
X-CUBE Control sensors <ul style="list-style-type: none"> ■ Anti-frost thermostat Black cable with black 3-pin M8 plug connection ■ Duct smoke detector 1 Black cable with black 4-pin plug connection ■ Duct smoke detector 2 Black cable with red 4-pin plug connection 	 <p>M8 plug connector</p>	Plug M8 plug connections together straight.
Fans with < 13 A power consumption are pluggable.	 <p>Plug the 5-pin power plug connectors</p>	together straight and close the retainer (protection against working loose).
Fans > 13 A, double fans or fan arrays	No discontinuities, rolled-up cables	Route the cables through the intended cable routes and connect them to the switch cabinet according to the circuit diagram.
Rotary heat exchanger	 <p>Plug the 3-pin power plug connectors</p>	together straight and close the retainer (protection against working loose).
Shut-off dampers with spring return actuator torque > 20 Nm	No discontinuities, rolled-up cables	Route the cables through the intended cable routes and connect them to the switch cabinet according to the circuit diagram.



None of the other regulation and control components are designed to be pluggable. The rolled-up cables must be routed through the intended cable routes and connected to the switch cabinet according to the circuit diagram.

Connecting cables



Fig. 33: Connection of the cables

1. ▶ Place the AHU casing units as close together as possible so that you can connect the cables.
Note: If there is not much space, you can also connect the cables inside the AHU.
2. ▶ First run the cables in sections through the AHU to the switch cabinet without discontinuities, see wiring diagram. Where cables have to be pulled in, e.g. behind heat recovery units, a pull wire is provided for pulling in the cable.
3. ▶ Then connect the separate cables according to the type of plug and the colours of the cable and plug, & ‘Interface connections’ on page 40 . Connect only cables with the same code.
4. ▶ When you push the AHU casing units together, feed the cables into the mesh cable trays and be careful to not damage any cables.

5.6.1 Connections and interfaces

Variant X2-Rxx

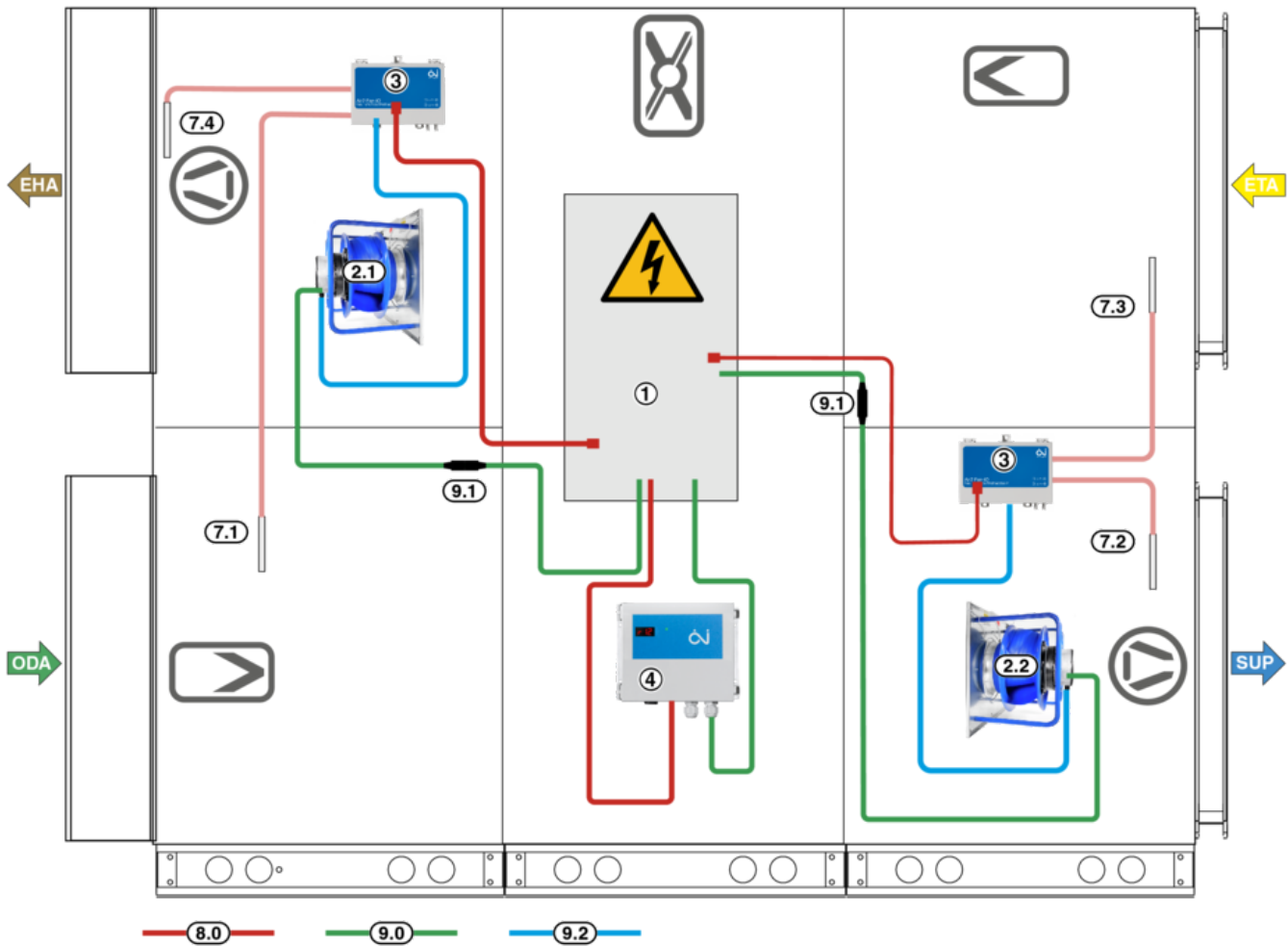

Fig. 34: Connection example of variant X2-Rxx (depending on the version, the components may be in other positions)

1	Switch cabinet	7.4	Exhaust air temperature sensor
2.1	Extract air fan	8.0	Modbus line
2.2	Supply air fan	9.0	Supply voltage cable
3	FAN IO	9.1	5-pin connection plug
4	Rotor controller	9.2	Cable between FAN I/O and fan
5	Filter	EHA	Exhaust air
7.1	Outdoor air temperature sensor	ODA	Outdoor air
7.2	Supply air temperature sensor	SUP	Supply air
7.3	Extract air temperature sensor	ETA	Extract air

Connecting separate cables

Bus lines with M12 plug connection

1. Pull the bus cables (RJ12 plugs) through the cable bushings and plug them into the FAN I/O or switch cabinet.

Connect the separate cables (output, grey)

2. with 5-pin connectors from the switch cabinet to the fans and the rotor controller and tighten the union nut.

Variant X2-RxxV

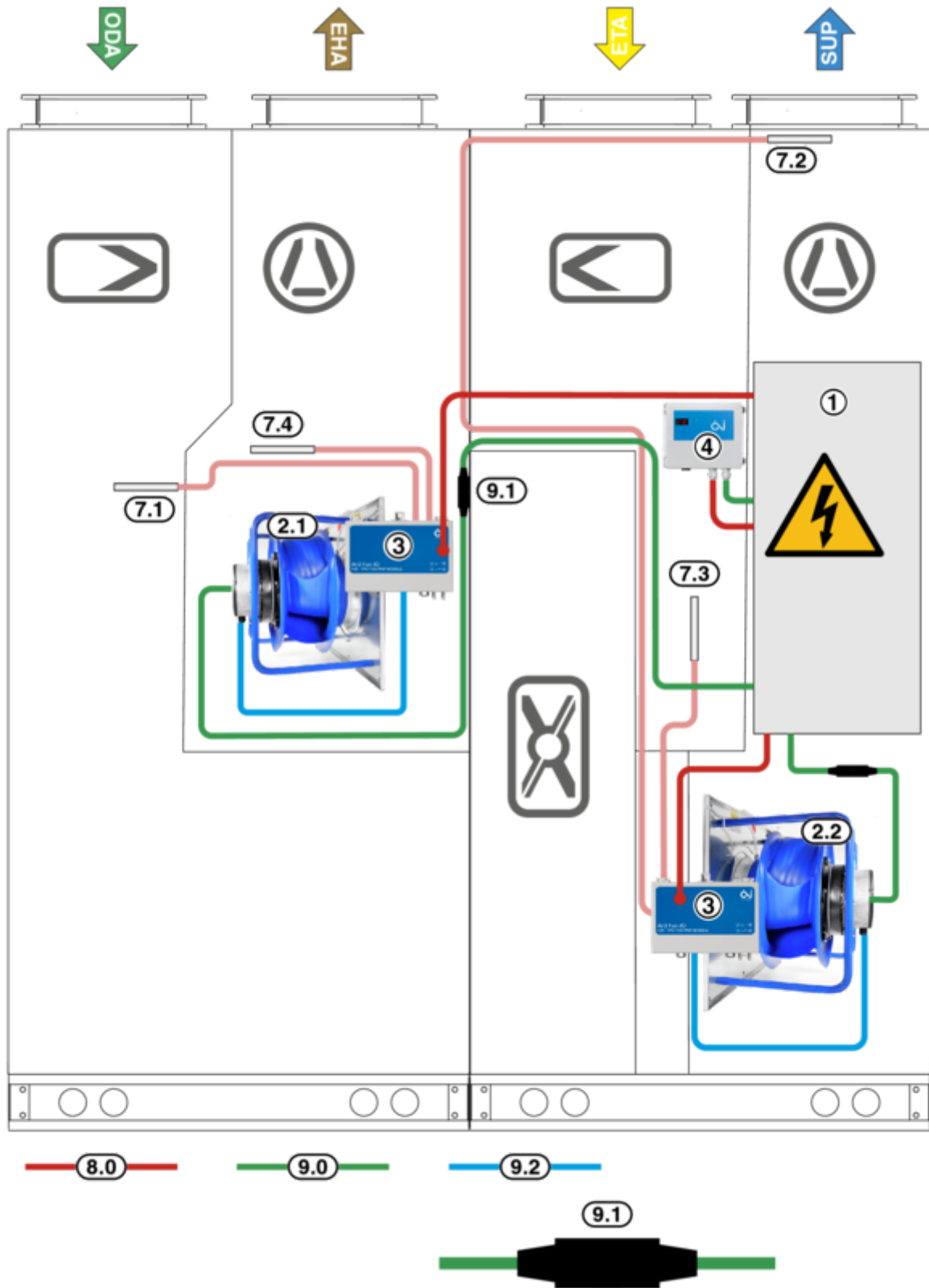

Fig. 35: Connection example of variant X2-RxxV (depending on the version, the components may be in other positions)

For legend, please refer to Fig. 34

Variant X2-Pxx

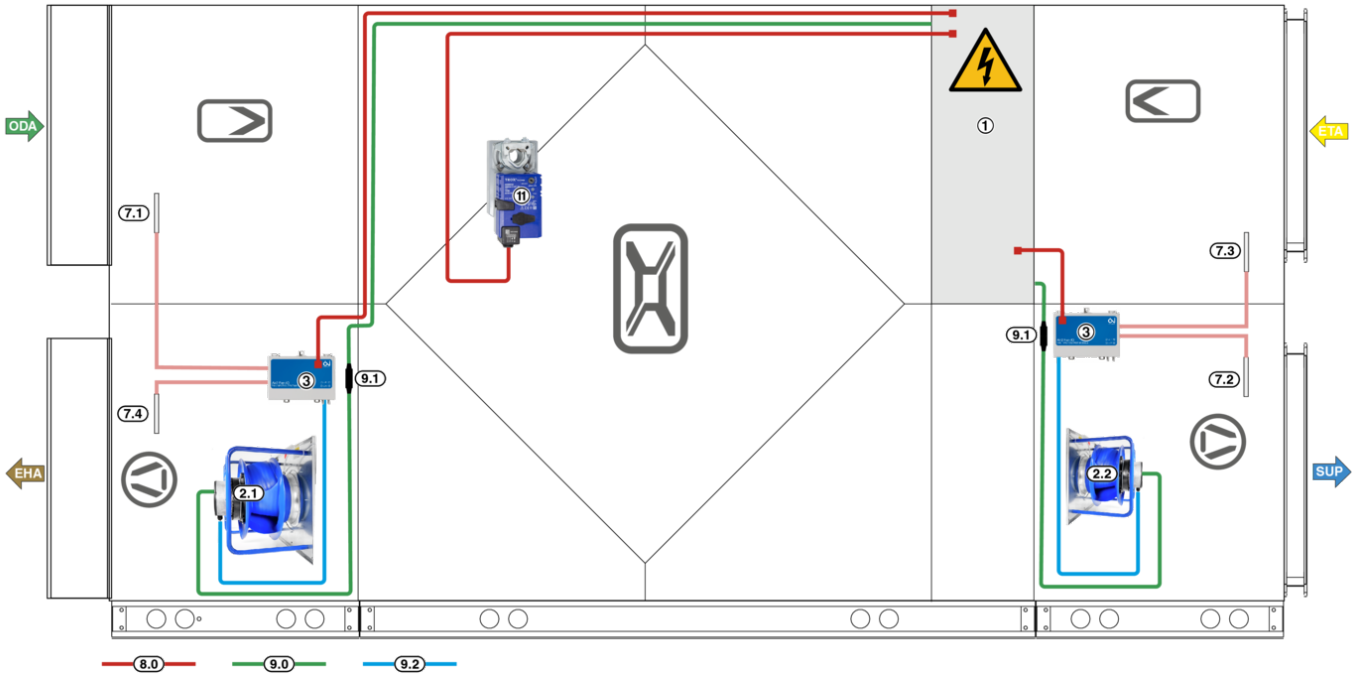

Fig. 36: Connection example of variant X2-Pxx (depending on the version, the components may be in other positions)

1	Switch cabinet	8.0	Modbus line
2.1	Extract air fan	9.0	Supply voltage cable
2.2	Supply air fan	9.1	5-pin connection plug
3	FAN IO	9.2	Cable between FAN I/O and fan
5	Filter	11	Actuator for bypass damper
7.1	Outdoor air temperature sensor	EHA	Exhaust air
7.2	Supply air temperature sensor	ODA	Outdoor air
7.3	Extract air temperature sensor	SUP	Supply air
7.4	Exhaust air temperature sensor	ETA	Extract air

5.6.2 Tube connections of differential pressure sensors

Variant X2-Rxx

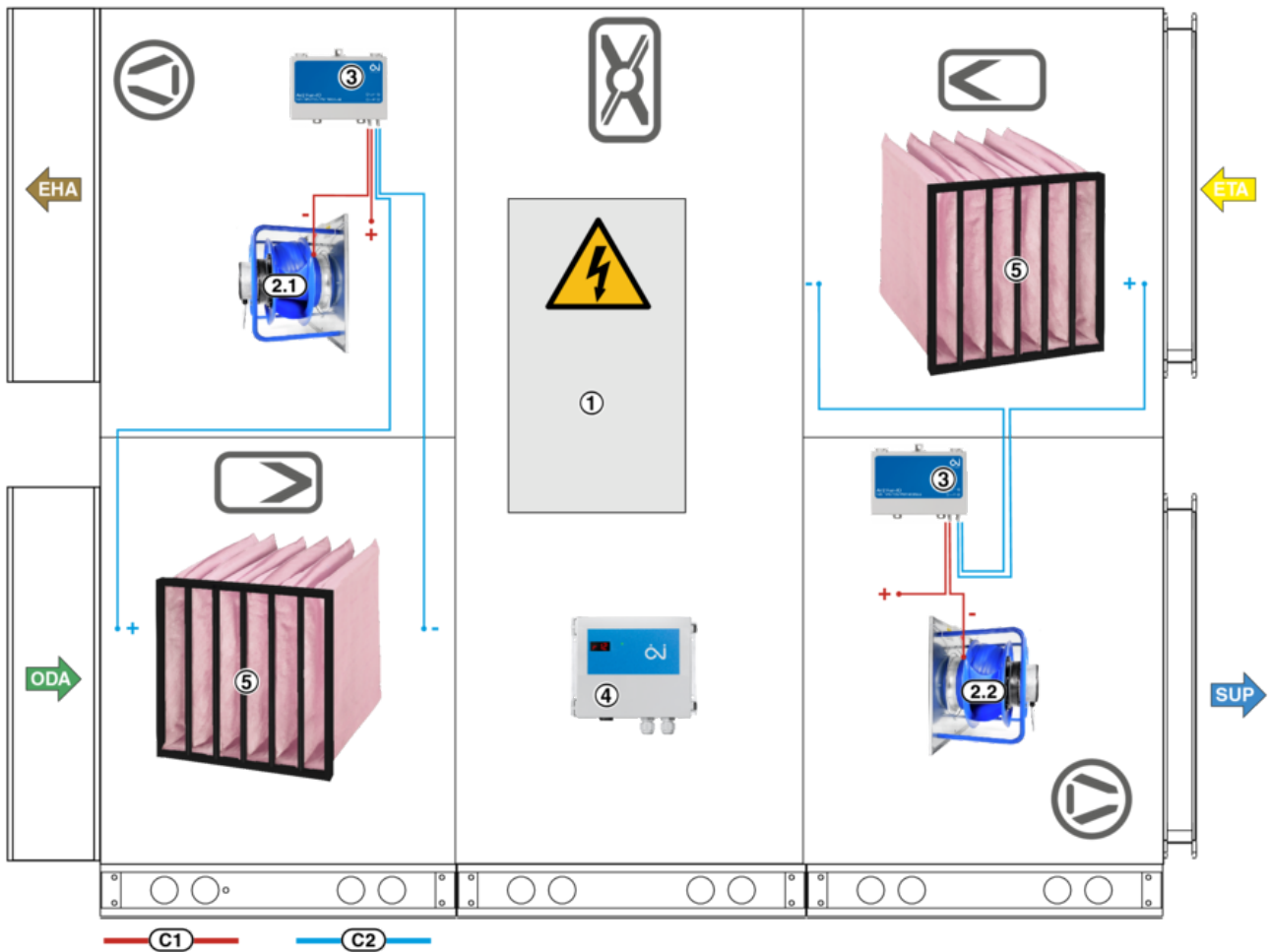

Fig. 37: Tube connections of variant X2-Rxx

- | | | | |
|-----|-----------------|-----|------------------|
| C1 | Duct 1 | 2.2 | Supply air fan |
| C2 | Duct 2 | 3 | FAN IO |
| 1 | Switch cabinet | 4 | Rotor controller |
| 2.1 | Extract air fan | 5 | Filter |

Variant X2-RxxV

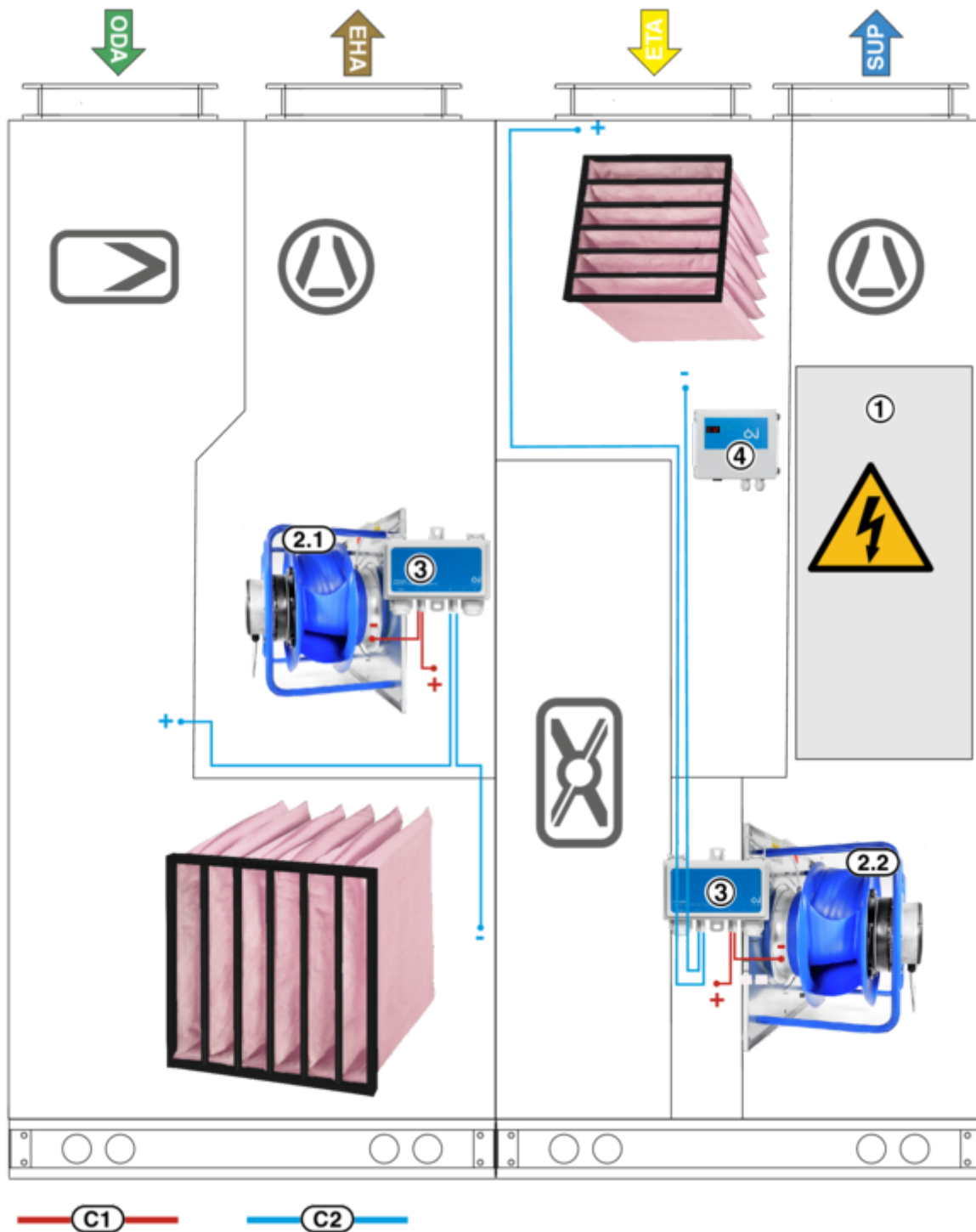

Fig. 38: Tube connections of variant X2-RxxV

For legend, please refer to Fig. 37

Variant X2-Pxx

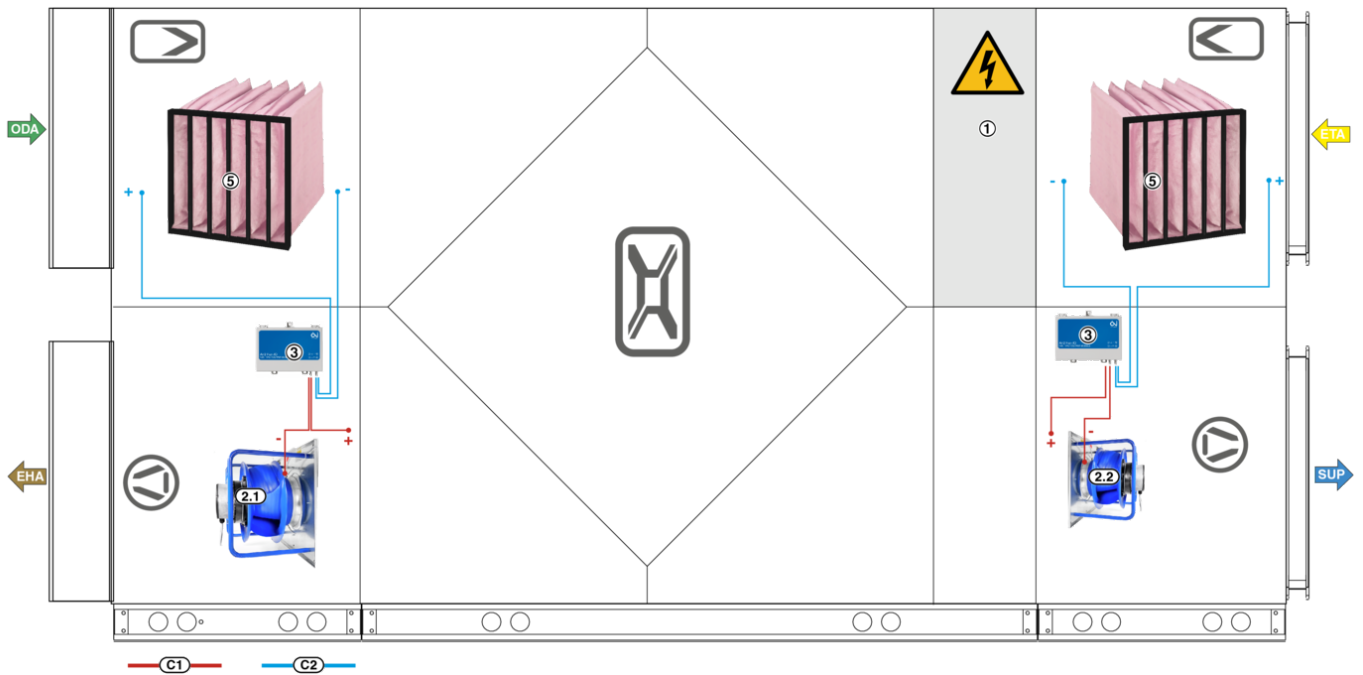

Fig. 39: Tube connections of variant X2-Pxx

- | | | | |
|-----|-----------------|-----|------------------|
| C1 | Duct 1 | 2.2 | Supply air fan |
| C2 | Duct 2 | 3 | FAN IO |
| 1 | Switch cabinet | 4 | Rotor controller |
| 2.1 | Extract air fan | 5 | Filter |

5.6.3 Connection of accessories

Heater / Cooler / DX Change-Over Register

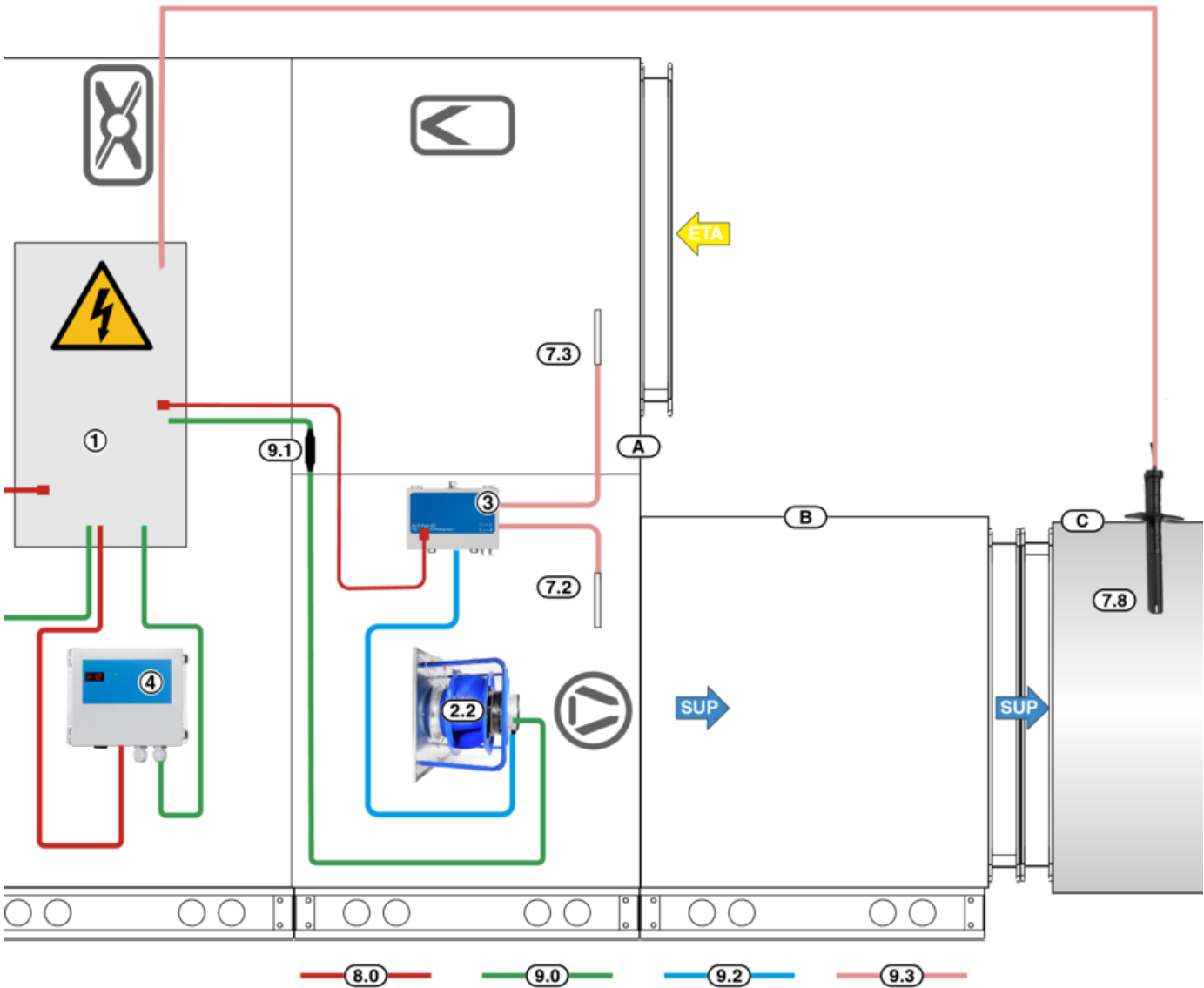

Fig. 40: Connection example (depending on the version, the components may be in other positions)

A	AHU	7.3	Extract air temperature sensor
B	Accessory module (cooler, heater, combination module or DX change-over register)	7.8	Supply air duct sensor
C	Duct (supply air)	8.0	Modbus line
1	Switch cabinet	9.0	Supply voltage cable
2.2	Supply air fan	9.1	5-pin connection plug
3	FAN IO	9.2	Cable between FAN I/O and fan
4	Rotor controller	9.3	Supply air duct sensor cable to switch cabinet
7.2	Supply air temperature sensor		

1. ▶ Fit the supply air duct sensor to the supply air duct.
2. ▶ Lead the cable to the switch cabinet and connect it according to the wiring diagram.

Electric air heater

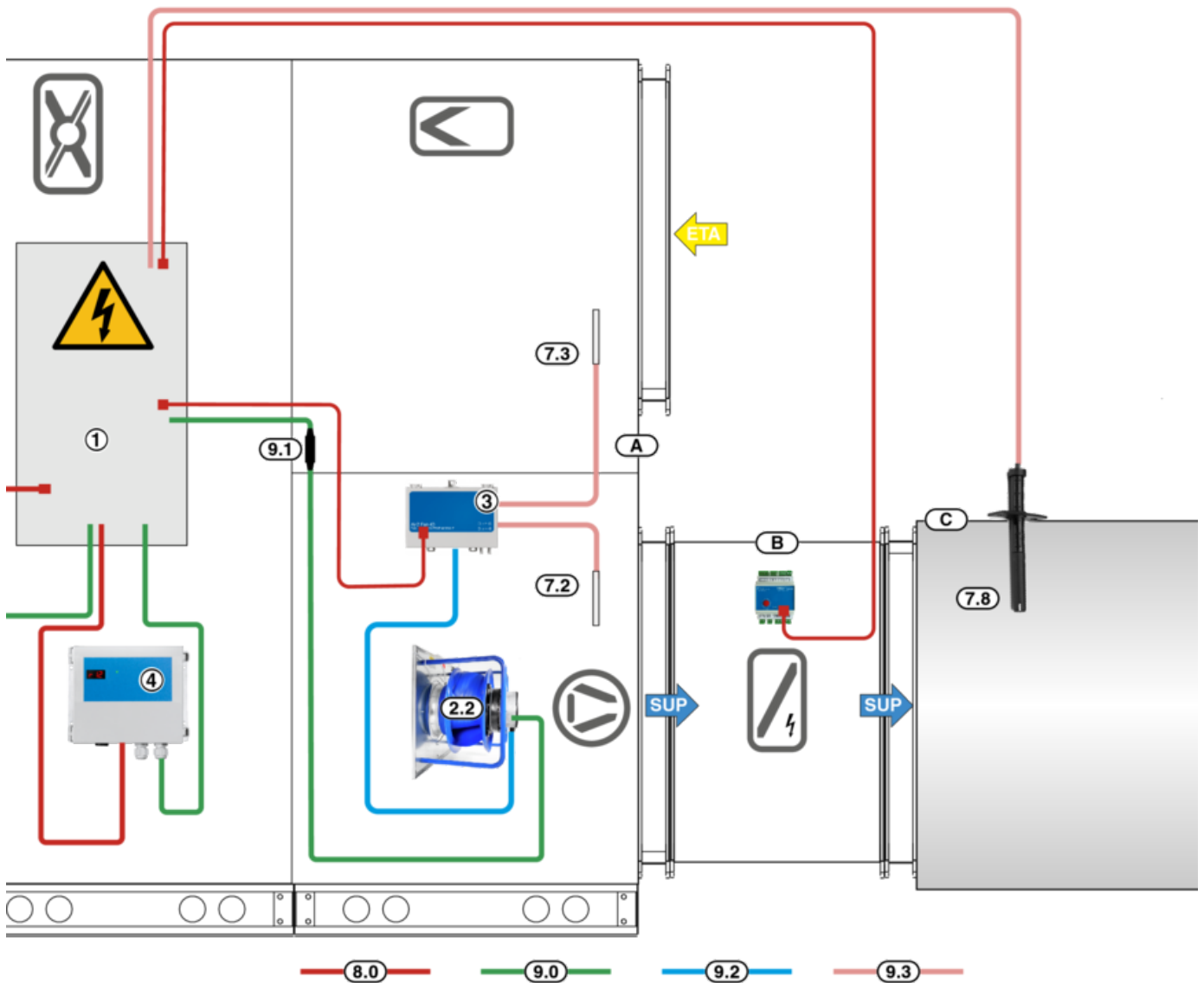

Fig. 41: Connection example (depending on the version, the components may be in other positions)

- | | | | |
|-----|---------------------------------|-----|--|
| A | AHU | 7.3 | Extract air temperature sensor |
| B | Accessory module (heating coil) | 7.8 | Supply air duct sensor |
| C | Duct (supply air) | 8.0 | Modbus line |
| 1 | Switch cabinet | 9.0 | Supply voltage cable |
| 2.2 | Supply air fan | 9.1 | 5-pin connection plug |
| 3 | FAN I/O | 9.2 | Cable between FAN I/O and fan |
| 4 | Rotor controller | 9.3 | Supply air duct sensor cable to switch cabinet |
| 7.2 | Supply air temperature sensor | | |

- ▶ Connect the supply voltage of the electric air heater according to the table and wiring diagram.

Type	Output [kW]	Voltage [V]	Phases [Ph]	Frequency [Hz]	Protection level	Wiring diagram/fig.
X2-R015/P015	5.4	400	2N	50	IP43	55942 Fig. 56
X2-R025/P025	9		3N			55943 Fig. 57
X2-R035/P035	12.6					55943 Fig. 57
X2-R050/P050	18					55943 Fig. 57
X2-R070/P070	25.2					55943 Fig. 57
X2-R090/P090	32.4					63185 Fig. 58
X2-R110	39.6					63185 Fig. 58
X2-R130	46.8		63186 Fig. 59			
X2-R150	54		63186 Fig. 59			
X2-R015V	5.4		2N			55942 Fig. 56
X2-R025V	9		3N			55943 Fig. 57
X2-R035V	12.6					55943 Fig. 57
X2-R050V	18					55943 Fig. 57

- ▶ Route the Modbus cable (flat cable max. 30 m) from the extension module of the electric air heater to the ControlMaster connection port B or C in the switch cabinet.
- ▶ Fit the supply air duct sensor to the supply air duct.

External damper

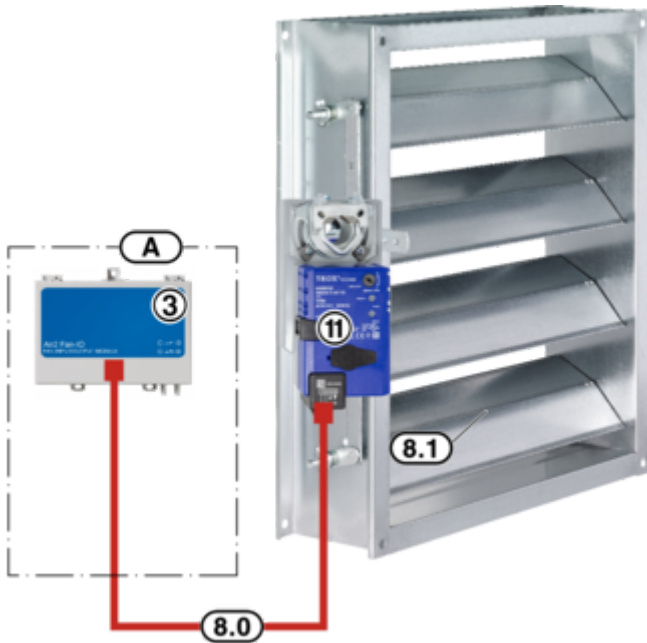

Fig. 42: Multileaf damper accessories

- A Extract air fan or upstream damper
- 3 FAN I/O (supply air or extract air)
- 8.0 Modbus line with RJ12 plugs
- 11 Multileaf damper with actuator

▶ Insert the bus lines from the accessories (black) with RJ12 plug connection through the M25 cable gland (remove blind plug) into the device and plug it into the corresponding FAN I/O.

Damper	FAN IO
Supply air	Supply air fan
Extract air	
Outdoor air	Extract air fan
Exhaust air	

Weather sensor

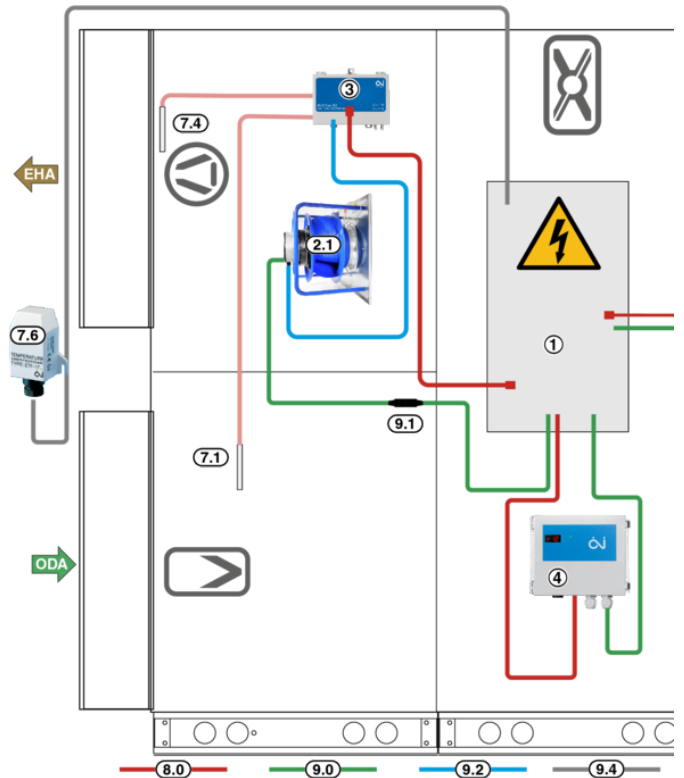

Fig. 43: Connecting the outdoor sensor

- 1 Switch cabinet
- 2.1 Extract air fan
- 3 FAN IO
- 4 Rotor controller
- 7.1 Outdoor air temperature sensor
- 7.4 Exhaust air temperature sensor
- 7.6 Weather sensor
- 8.0 Modbus line
- 9.0 Supply voltage cable
- 9.1 5-pin connection plug
- 9.2 Cable 4 x 1mm²
- 9.4 2-wire cable (to be provided by others)

1. ▶ Insert the connecting cable of the outdoor sensor through the cable gland to the switch cabinet.
2. ▶ Connect the outdoor sensor with a 2-wire cable to the switch cabinet (no polarity dependence)

Note on the connecting cable: Cable cross-section maximum 1.5 mm² (WAGO terminals), sheathed cable Ø 5 to 9 mm, (tightness M16 gland), observe VDE regulations or local regulations.

Connecting the air handling unit to your PC or l...

5.7 Connecting the AHU to the power supply

Electrical connection

⚠ DANGER!

Danger of death due to electric current!

Danger of electric shock! Do not touch any live components!

- Only a skilled qualified electrician must connect the power supply.
- For air handling units with integral controls use the circuit diagram in this manual, ↗ 'Other applicable documentation' on page 3
- Lay connecting cables in such a way that they cannot be accidentally damaged by mechanical impact or by heat.
- Bridge all non-conductive joints, such as connecting frames, flexible connectors and anti-vibration elements, with an equipotential bonding cable.
- Earth the air handling unit according to the state of the art.
- Secure all connections so that they cannot come loose.
- When you connect any electrical components, follow the manufacturers' specifications, the local regulations and codes of good practice (DIN/VDE), and the general recommendations for avoiding electromagnetic interference,
- If an AHU is installed outdoors, do not neglect the effects of weather on the unit (rain, snow, wind, sun etc.).



If you have to attach brackets or fasteners to the AHU panels or frame, use only those specially approved for your AHU as otherwise there is a risk of leakages. Avoid screw joints that pierce the outer shell of the unit; if you cannot avoid them, then at least seal them to prevent the ingress of water. The minimum protection level is IP 65.

1. ▶



Units with controls

The electrical circuit diagrams and terminal plans can be found in the circuit diagram included in the supply package.

Connect the electrical components, such as the electric air heater, electric motor, and actuator.

2. ▶ Include the air handling unit in the equipotential bonding arrangement.
3. ▶ Test protective conductors and insulation resistance to EN 60204 (VDE 0113). Take the appropriate safety precautions!

5.8 Integrating the air handling unit with the MCE

It is the duty of the system owner/HVAC contractor to integrate the air handling unit with the building services and to ensure conformity, ↗ 'System owner's obligations' on page 10 and ↗ 'Conformity assessment' on page 20 .

5.9 Connecting the air handling unit to your PC or local network

Network or PC

Personnel:

- Network administrator
- HVAC technician

Protective equipment:

- Industrial safety helmet
- Hearing protection
- Protective gloves
- Protective clothing
- Safety shoes

- ▶ Connect one end of the network cable to the AHU and the other end to your PC or local network.

Cable gland on the X-CUBE Compact 2

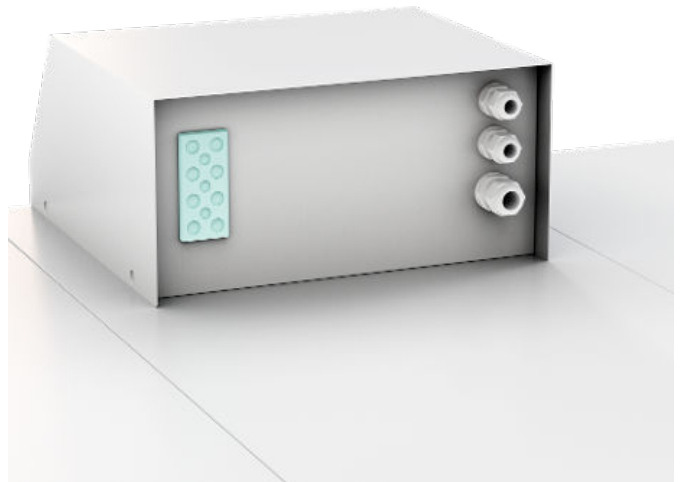

Fig. 44: Cable glands, e.g. at the back of the control unit

Modbus RTU

The Modbus-RS485 interface can be used to connect the AHU to a remote terminal unit (RTU). This allows you to display measurement values and to adjust set-point values via an external BMS or CTS.

The following bus interfaces are also available:

- Modbus RTU
- Modbus TCP/IP
- Integral web server

- BACnet
- LON (accessory)

Personnel:

- Qualified electrician

Protective equipment:

- Industrial safety helmet
- Hearing protection
- Protective gloves
- Protective clothing
- Safety shoes

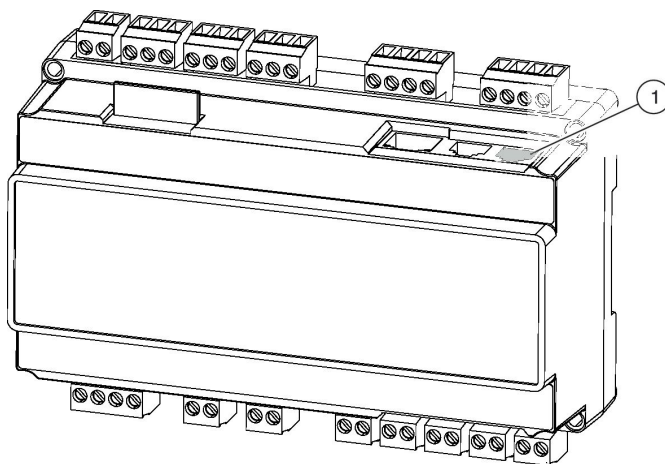

Fig. 45: Modbus RS485 interface

- ▶ Use the Modbus-RS485 interface (Fig. 45 /1) to connect the X-CUBE control master to a remote terminal unit (RTU).

5.10 Setting the bus address for accessories

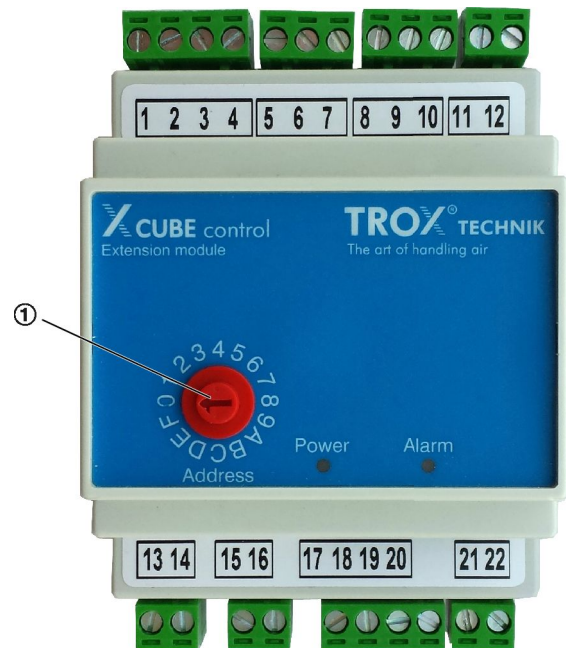

Fig. 46: Extension Module

- ① Rotary button for setting the address

The extension module is fitted in the switch cabinet; the number of modules depends on the unit construction

Address settings

Accessories	Address
Heating coil	3
Cooling coil	4
Heating coil / cooling coil	Heating coil: 3 Cooling coil: 4
Electric duct air heater	5
Evaporator	7
Preheater (electric or hot water)	8
Constant pressure control	0 (supply air), 1 (extract air)
Digital control panel	Is automatically recognised

6 Initial commissioning

6.1 Safety notes regarding initial commissioning

Incorrect initial commissioning

 **WARNING!**

Risk to life from incorrect initial commissioning!

Incorrect initial commissioning can lead to potentially fatal situations and cause considerable damage to property.

- Only skilled qualified electricians must work on the electrical system and on motors.
- All other initial commissioning steps must be carried out by an HVAC technician.

Inspection access doors on the discharge side

 **CAUTION!**

Risk of injury from a strong airflow on the discharge side of fans!

When you open an inspection access door on the discharge side of the fan, the velocity and pressure of the airflow may cause the door to suddenly swing open until it is caught by the safety catch. You could be injured.

- Be careful when you open inspection access doors on the discharge side.

Sharp edges, sharp corners and thin sheet metal parts

 **CAUTION!**

Danger of injury from sharp edges, sharp corners and thin sheet metal parts!

Sharp edges, sharp corners and thin sheet metal parts of the heat exchanger or of the cooling or heating coil may cause cuts or grazes.

- Be careful when working on these components.
- Wear protective gloves, safety shoes and a hard hat.

Inspection access doors slamming shut

 **WARNING!**

Risk of crushing from doors slamming shut

Inspection access doors may slam shut by the wind or if someone pushes them inadvertently, resulting in serious injury to the head and limbs.

- Secure each inspection access door with a hold open device.
- Secure inspection access doors without a hold open device against closing by suitable means.
- Do not reach between the door and door frame.
- Wear protective gloves and a hard hat when you open an inspection access door.

Crushing hazard!

 **WARNING!**

Crushing hazard from movable parts!

There is an increased risk of crushing on casing units, doors, panels and components of the device.

- Never reach between moving parts.
- Be careful when carrying out any work.
- Wear protective gloves, safety shoes and a hard hat.

Damage to inspection access doors

 **NOTICE!**

Physical damage to inspection access doors

Do not open inspection access doors which are hinged on one side if their width is ≥ 1000 mm or more!

The closures can be damaged due to the weight and the leverage forces that occur.

In the case of inspection access doors from a width of ≥ 1000 mm, always open all closures and remove the door from the air handling unit.

Store doors safely where they are protected against damage!

6.2 Before initial commissioning

The air handling unit has been erected, assembled, and installed according to this manual.

Before initial commissioning, check the entire casing and the following parts for damage and correct position:

- Inspection access doors and openings
- Seals
- Handles and levers

- Connections
- Inspection window
- Panels

Before initial commissioning:

- Remove protective film, if any
- Check the unit for leakages
- Check inspection access doors and openings for function
- Set up the centrifugal fan, ↗ 'Setting up the centrifugal fan' on page 55 Set up the centrifugal fan,
- Insert the filters, ↗ 'Filters, inserting' on page 57
- Set up the heating coil/cooling coil, ↗ 'Commissioning the heating coil/cooling coil' on page 57
- Set up the multileaf dampers, ↗ 'Setting up multileaf dampers' on page 59
- Set up the sound attenuator, ↗ 'Setting up sound attenuators' on page 59
- Set up the rotary heat exchanger, ↗ 'Setting up the rotary heat exchanger' on page 60
- Set up the plate heat exchanger, ↗ 'Setting up the plate heat exchanger' on page 60
- Remove the protective cap from the condensate drains and connect the drain trap, ↗ Chapter 5.3 'Connecting the condensate drain' on page 35
- Clean the air handling unit, ↗ Operating manual, Chapter: Maintenance.

6.3 Setting up and adjusting AHU casing units

6.3.1 Ⓢ Centrifugal fan

Operating point

The control system calculates the operating point and sets the default setpoint value for the fan.

During commissioning ensure that the following values are not exceeded:

- Maximum fan speed
- Minimum fan speed
- Motor rating

Do not change the clearance between the rotor and the bellmouth inlet.

Setting up the centrifugal fan

WARNING!

Risk of injury from the incorrect handling and operation of fans!

Incorrect handling, e.g. reaching into rotating parts, can lead to serious injuries.

- Do not reach into the moving fan or tamper with it.
- The fan does not stop immediately! Check that no parts are moving before you open an inspection access door.
- Do not put a damaged or defective fan into operation.
- Do not exceed a fan's maximum capacity, e.g. when there are strong vibrations or against a closed multileaf damper.
- Switch off the AHU before you start working on movable fan parts and secure it against accidentally being switched on again. Wait until all parts have come to a standstill.

WARNING!

Risk of fire from damaged fan parts!

Grinding rotors or overheating bearings can cause a fire and eventually serious or even fatal injuries.

- Do not put a damaged or defective fan into operation.
- The power consumption must not exceed the specified nominal current.
- Make sure that the maximum motor speed is not exceeded.

Personnel:

- Skilled qualified electrician

Protective equipment:

- Protective clothing
- Hearing protection
- Industrial safety helmet
- Protective gloves
- Safety shoes

1. ▶ Remove the red transport protection devices from the fan.
2. ▶ Check the fan for shipping damage, imbalance, corrosion and contamination.
3. ▶ Check ducts and fan for foreign matter.

4. ▶ Turn the rotor manually to check that it moves freely.



The clearance between the rotor and the bell-mouth inlet may have changed due to vibrations during transport. Check before commissioning that the distance between the inner edge of the rotor and the outer surface of the bellmouth inlet is the same everywhere.

5. ▶ Tighten all fixing screws.
6. ▶ Check the bearings and relubricate them if necessary.
7. ▶ Make sure that the multileaf dampers are open, ↪ 'Setting up multileaf dampers' on page 59 .
8. ▶ Check the direction of rotation of the fan by switching on the motor for a moment.



Nominal motor power of 3 kW and higher: star delta start.



In units with a fan with asynchronous motor, the arrow indicating the direction of rotation can be found on the fan casing.

In units with an EC fan, the fan will automatically start in the correct direction of rotation.

9. ▶ You can change the direction of rotation by swapping the terminal connections.
- 10.▶ Ensure that the unit has been correctly earthed.
- 11.▶ Close all inspection access doors on the air handling unit ↪ Operating manual.
- 12.▶ Measure the current consumption with the inspection access doors closed and compare it with the nominal current.



If the current consumption exceeds the value given on the motor rating plate, switch off the fan immediately.

- 13.▶ Check the function of the anti-vibration elements.
- 14.▶ Moving towards all possible operating points, check whether the fan is running smoothly and with minimal vibration only.

! NOTICE!

Material damage due to strong vibrations or resonances!

Vibrations or resonances can cause considerable damage to the fan.

Therefore, a vibration check of the fans must be carried out before commissioning in order to exclude vibrations caused by unsteady running (imbalance), e.g., due to damage from transport or installation. We recommend a vibration test of the fans for mechanical vibrations in accordance with ISO 14694.

Be sure to take adequate precautions in the process:

- In the event of unusual oscillations, vibrations, temperatures or bearing noises, switch off the AHU immediately and inform ↪ *TROX Technical Service* .
- Check the system for resonances. If unacceptably high vibrations occur at the fan at an operating point, the system must not be put into operation or the critical speed range must be blocked. ↪ Fan manufacturer's documentation.
- For fans with frequency inverter (FI), also observe the fan manufacturer's documentation for commissioning!

- 15.▶ Measure the volume flow rate.
⇒ The centrifugal fan has been set up.

6.3.2 Filter unit

Filters, inserting

Personnel:

- HVAC technician

Protective equipment:

- Industrial safety helmet
- Protective clothing
- Protective gloves
- Safety shoes



- *Filters may become contaminated due to construction work in the building which is why we recommend that you replace all filters after the construction phase and initial commissioning.*
- *Do not operate the air handling unit without a filter.*
- *One spare filter element should always be available so that the air handling unit does not have to be switched off. Store filters in a dry place, free from dust, so that they will not be contaminated or damaged. Do not use filters beyond the use before date. Original TROX filters carry a sticker on the frame with both the use before date and information on how to order replacements.*

1. ▶ Ensure that the filters are intact.



Defective filters may become torn while in use and will then no longer be effective.

2. ▶ Remove any dust from all parts that are in upstream direction before the filter.



Clean the air handling unit and ventilation ducts before you install any filter of class F9 or higher.

3. ▶ Fit filters into the installation subframe and fix them with the clamping elements. Make sure that they are tightly seated.

⇒ The filter has been set up.

6.3.3 Heating coil/cooling coil

Heat transfer fluids with glycol



WARNING!

Health risk from heat transfer fluids that contain glycol!

The heat transfer fluids in the heating coil, cooling coil and run-around coil system contain glycol, which can cause serious health damage in the event of physical contact, swallowing or inhalation of aerosols.

- Avoid contact with heat transfer fluids that contain glycol.
- Work must only be carried out by qualified refrigeration technicians, HVAC technicians or the  TROX Technical Service .
- Do not eat, drink or smoke while handling heat transfer fluids that contain glycol.
- Wash your hands when you interrupt or finish your work.
- If you have come into contact with a heat transfer fluid that contains glycol, follow the first aid instructions given on the safety data sheet for the heat transfer fluid.
- When you have to handle a heat transfer fluid that contains glycol, wear the personal protective equipment specified in the safety data sheet for the heat transfer fluid.

Commissioning the heating coil/cooling coil

Personnel:

- HVAC technician

Protective equipment:

- Industrial safety helmet
- Protective clothing
- Protective gloves
- Safety shoes



Ensure that the maximum pressure values given in the technical data are not exceeded.

Use appropriate measures to protect the water system from frost. Frost protection can be achieved with a water glycol mixture or with a special anti-frost thermostat.

Optimum ventilation

For the best possible ventilation, we recommend installing on-site ventilation equipment at the highest point of the system; see  on page 37.

1. ▶ Ensure that the flow and return connections are correct.
2. ▶ Check that fittings are correctly installed.
3. ▶ Flush the system to remove any contamination.
4. ▶ Open vents (unless automatic vents have been installed).



Evaporators: As soon as you open the heat exchanger connection, the contained nitrogen shield gas content should escape with a hissing sound. The absence of this sound indicates a leak which has to be fixed before commissioning.

5. ▶



For glycol water mixtures we recommend ready-to-use formulations. See the order-specific air handling unit data sheet from TROX for the mixing ratio.

The correct mixing ratio is important:

- Too much glycol will impair performance
- Too little glycol may lead to frost damage

Only use one of the following glycols for the air handling unit:

- Propylene glycol
- Ethylene glycol

Slowly pour the heat transfer fluid into the heat exchanger at the lowest point in the system. As you fill the system, check that all external and internal screw joints and connections are tight.

6. ▶ Vent the heating coil/cooling by opening the upper spigot and the bleed screw.



If the air heater is not properly vented, air bubbles may form and impair the performance.

7. ▶ Close any vents.
8. ▶ Clean the condensate drip tray and drain.
9. ▶ Set up the droplet eliminator.
10. ▶ Fill the drain trap with water.

NOTICE!

Risk of damage to property!

- When you tighten thread connections, be sure to use a suitable tool (e.g. water pump pliers) to counter the tightening force as otherwise you may inadvertently damage the parts.

11. ▶ Check the flange screw joints and tighten them if necessary.

⇒ The heating coil/cooling coil has been set up.

6.3.4 Electric air heater

Personnel:

- Skilled qualified electrician

Protective equipment:

- Protective clothing
- Hearing protection
- Industrial safety helmet
- Protective gloves
- Safety shoes

In air handling units with X-CUBE Control (controls), both the temperature monitoring and the safety temperature limiter operate independently of one another to ensure that no inadmissible overheating occurs at the electric air heater.

For air handling units with on-site controls, on-site measures must be taken to prevent impermissible temperature excesses. The manufacturer documentation must be observed for this purpose, see attachment.

CAUTION!

Protection against overheating

The electric air heater must be installed so that the heating elements cannot start up before the intended air volume flow is reached. The electric air heater must be put out of operation as soon as the volume flow rate is reduced to a level that is not permitted or the fan is switched off.

To prevent a temperature excess that is not permitted, two temperature-limiting devices must be installed in the air handling unit independently of each other (temperature monitor and safety temperature limiter).

6.3.5 Multileaf dampers

Movable parts of multileaf dampers



WARNING!

Crushing hazard from movable parts!

Closing multileaf dampers may crush your hands and arms.

- Do not reach between the damper blades.
- Prevent access to crush points: Either install dampers on ducts or use fixed guards.
- Before you open an inspection access door, switch off the air handling unit and secure it against being switched on accidentally.

Setting up multileaf dampers

Set the AHU control system in such a way that the fan does not operate against a closed damper.

TROX does not accept liability for damages resulting from incorrect operation. To prevent damage due to pressure surges from fire dampers, pressure relief dampers should be installed.



TROX cannot guarantee leak-free dampers if the actuators are provided and installed by others.

Powered dampers

Personnel:

- HVAC technician

Protective equipment:

- Industrial safety helmet
- Protective clothing
- Protective gloves
- Safety shoes

- ▶ Adjust the linkage in such a way that the angle of rotation is 90° and the dampers close completely.

⇒ Powered multileaf dampers have been set up.

Coupled dampers (for plate heat exchanger)

Personnel:

- HVAC technician

Protective equipment:

- Industrial safety helmet
- Protective clothing
- Protective gloves
- Safety shoes

1. ▶ Check that the friction locking of the linkage is correct.

2. ▶ Check the direction of rotation direction and ensure that the blades fully open and close.
3. ▶ Check that all screw joints and connections are tight.
 - ⇒ The coupled multileaf dampers have been set up.

6.3.6 Sound attenuator

Setting up sound attenuators

The splitter filling is made of non-combustible absorption material to DIN 4102.

Personnel:

- HVAC technician

Protective equipment:

- Industrial safety helmet
- Protective clothing
- Protective gloves
- Safety shoes

- ▶ Check splitters for damage and contamination.

⇒ The sound attenuator has been set up.

6.3.7 Rotary heat exchanger



WARNING!

Risk of injury from rotating parts!

Incorrect handling, e.g. reaching into rotating parts, can lead to serious injuries.

Never reach into or tamper with the storage mass

- Switch off the system before you start working on movable parts of the rotary heat exchanger and secure it against accidentally being switched on again. Wait until all parts have come to a standstill.
- Do not put a damaged or defective rotary heat exchanger into operation.

Adjusting the rotary heat exchanger

The storage mass of the rotary heat exchanger is factory set. You may have to adjust the storage mass to the actual installation conditions, see the manufacturer's documentation.

Setting up the rotary heat exchanger

Personnel:

- HVAC technician

Protective equipment:

- Protective clothing
- Hearing protection
- Industrial safety helmet
- Protective gloves
- Safety shoes



Ensure that permitted values for parameters such as temperatures or differential pressure are not exceeded.

- ▶ Check whether the system has been correctly installed.
- ▶ Inspect the rotary heat exchanger for foreign matter.
- ▶ Check that the rotor moves freely.



See the manufacturer's documentation.

- ▶ Check the rotation direction of the rotor and change it on the motor controller, if necessary. Follow the manufacturer's operating instructions.



If the heat exchanger includes a purge sector, the rotating storage mass passes from the extract air via the purge sector to the supply air.

- ▶ Check that the control module functions correctly.
- ▶ Check the drive belt tension.
- ▶ Set up the drive equipment, ☞ 'Setting up the drive equipment' on page 60.
- ▶ Check that the seals are tight; readjust them, if necessary.



See the manufacturer's documentation.

⇒ The rotary heat exchanger has been set up.

Setting up the drive equipment

Personnel:

- Skilled qualified electrician

Protective equipment:

- Protective clothing
- Hearing protection
- Industrial safety helmet
- Protective gloves
- Safety shoes

We recommend that you check the tension of the drive belt regularly during the first 400 hours of operation.

- ▶ Open the inspection access panel on the indicated corner of the rotor casing.
- ▶ Check whether the drive belt has sufficient tension; if necessary, shorten the belt as follows:

Shortening the drive belt

- ▶ Open the lock.
- ▶ Shorten the belt as required.
- ▶ Close the lock.
- ▶ Close the inspection access panel.

Checking the motor

- ▶ Ensure that the motor is securely fixed.
⇒ The drive equipment has been set up.

6.3.8 ☒ Plate heat exchanger

Setting up the plate heat exchanger

Personnel:

- HVAC technician

Protective equipment:

- Industrial safety helmet
- Protective clothing
- Protective gloves
- Safety shoes

! NOTICE!

Risk of damage to property from extreme pressure drop!

An extreme pressure drop between the supply air and extract air flows can damage the heat exchanger.

- Ensure that the maximum differential pressure (approx. 1000 Pa, depending on unit design) is not exceeded.
- Check differential pressure on pressure monitors according to the specified intervals.

- ▶ Check and, if necessary, clean the plate heat exchanger to remove foreign matter and contamination.

⇒ The plate heat exchanger has been set up.

6.3.9 Electrical system

Personnel:

- Skilled qualified electrician

Protective equipment:

- Protective clothing
- Hearing protection
- Industrial safety helmet
- Protective gloves
- Safety shoes

Before commissioning, the electrical system has to be tested according to IEC 60364-6 (VDE 0100-600). As part of this test, all contacts have to be checked on site for tight fit. This applies in particular to motor terminal blocks, fuses, local isolators etc.

6.4 Starting the air handling unit

6.4.1 Before you start the AHU

Before you switch on the AHU, make sure that the following requirements have been met:

- Has the air handling unit been checked for damage?
- Have the transport protection devices been removed?
- Have the filters been inserted?
- Have all inspection access doors and openings been closed?
- Have all inspection access panels been closed?
- Have all air ducts in the AHU been connected?
- Have the AHU and the connected air ducts been tested for any leaks?
- Has the interior of the air handling unit been cleaned?
- Have all drain traps been filled with water?
- Are all requirements for the supply media met?
- Has all the safety equipment been installed? Does it work properly?
- Have all the electrical connections been made and secured according to the relevant national standards?
- Has the heating coil/cooling coil been correctly connected and filled?
- Has the centrifugal fan been set up?
- Have the multileaf dampers been set up?
- Has the sound attenuator been set up?
- Has the rotary heat exchanger been set up?
- Has the run-around coil system been correctly filled?
- Has the plate heat exchanger been set up?
- Are the operating conditions in accordance with the intended use?

6.4.2 Activating accessories



1. ▶ Use the supplied bus cable to connect the touch panel to the corresponding cable entry point, see the wiring diagram.
2. ▶ Switch on the power supply for the accessory.

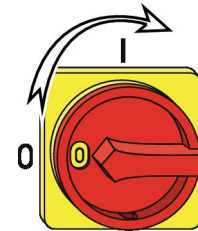

3. ▶ Turn the mains isolator of the compact unit to I/ON



4. ▶ Use the touch panel to activate accessories. For details on using the touch panel refer to the X-CUBE compact operating manual.



5. ▶ The unit recognises connected accessories automatically. After approx. 5-30 s a message is displayed on the touch panel (example shown).



6. ▶ Enter your password and confirm it with ✓.
Default password: 0022



7. ▶ To activate the accessory, press ✓.
⇒ Once an accessory has been activated, you can configure it. For details refer to the X-CUBE compact operating manual.

6.4.3 Deactivating accessories

Use the touch panel to deactivate accessories. For details on using the touch panel refer to the X-CUBE compact operating manual.



1. ▶ Select the 'Menu'.



2. ▶ Select 'Settings'.

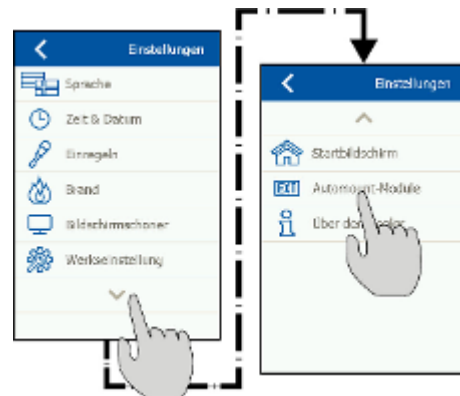

3. ▶ Select the arrow to display more settings, then select 'Automount modules'.



4. ▶ Select the accessory you want to deactivate.



- 5. ▶ Enter your password and confirm it with ✓.
Default password: 0022



- 6. ▶ Press ✓ to deactivate the accessory.
⇒ The accessory is now no longer active.

6.4.4 Switching on

Personnel qualified to start the air handling unit

Only specially trained individuals must start the air handling unit.

Follow the instructions in the operating manual for the air handling unit.

If the unit is not fitted with integral controls (MSR system), i.e. if the controls have been supplied by others, follow the instructions of the supplier.

6.5 Configuring the air handling unit

6.5.1 X-CUBE controller communication, setup

Personnel:

- HVAC technician

! NOTICE!

Risk of damage to property from incorrect use

The service interfaces of the touch panel (/4) and TCP/IP network (/5) are intended for temporary use (e.g. service).

When not in use, protect the service interfaces from the weather by fitting caps.

If the device is used for a long period of time, it may be damaged by moisture, especially if it is installed outdoors.

The permanent and professional installation of the bus connecting cables is carried out at the inputs and outputs of the control master using the existing cable penetrations as cable glands; see .



If any accessories have been installed be sure to follow the installation and commissioning instructions for those accessories before you start configuring the unit.

You can assign the X-CUBE controller a static IP address; as an alternative, the controller can receive a dynamic IP address (DHCP) via the network.



Default IP address:

192.168.2.1

If you intend to connect the air handling unit to a personal computer, you need to set the static IP address on the touch panel. If you intend to integrate the air handling unit with a network, you need to obtain the IP address dynamically (DHCP) from the network.

1. ▶ Start the air handling unit.
2. ▶ On the touch panel, select 'Menu → Settings → Language'.

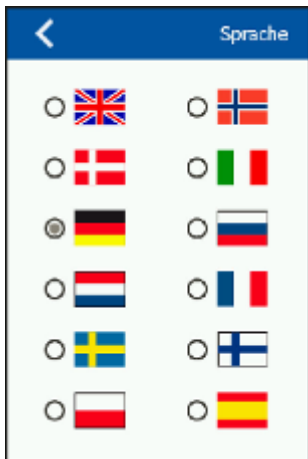

Fig. 47: 'Language' window

3. ▶ Select a language.
4. ▶ On the touch panel, select 'Menu → Communication'.

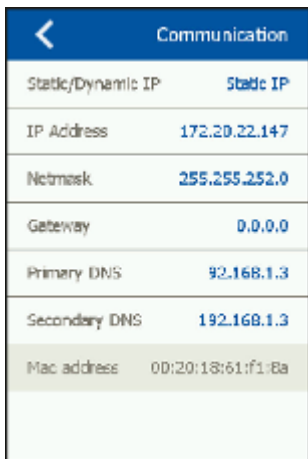

Fig. 48: 'Communication' window

5. ▶ Select 'Static IP/DHCP'.

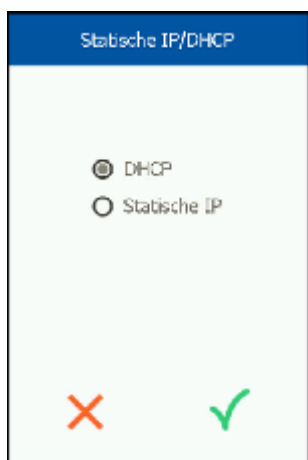

Fig. 49: DHCP or static IP

6. ▶ Set the static IP address or set dynamic assignment of the IP address (DHCP), then confirm your selection with ✓.

⇒ Communication for the X-CUBE controller has been set up.

6.5.2 Setting up network communication

Personnel:

- HVAC technician

If you want to use a PC to communicate with the air handling unit you have to set up the network connection. The following steps apply to a Windows PC.

1. ▶ On the desktop, select 'Start → Control Panel → Network and Internet → Network and Sharing Center'.

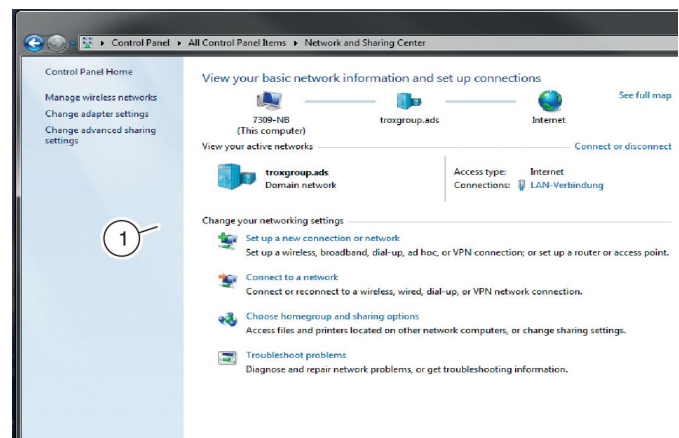

Fig. 50: Setting up a new connection or network

2. ▶ Select 'Set up a new connection or network' (Fig. 50 /1).

⇒ The 'Set up a connection or network' window opens.

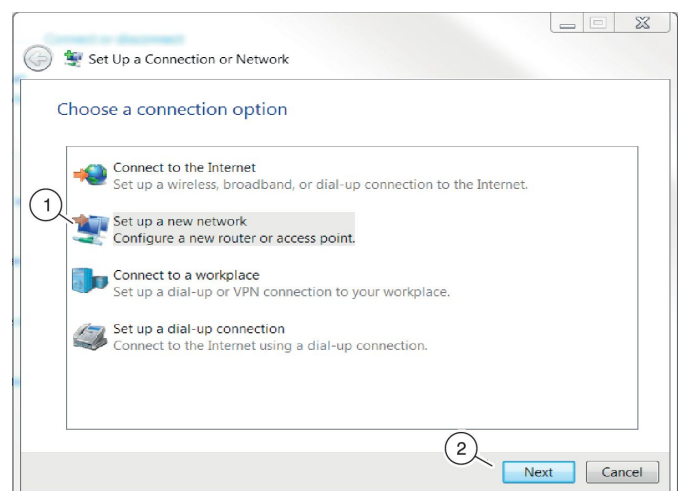

Fig. 51: Setting up a new network

3. ▶ Select 'Set up a new network' (Fig. 51 /1), then click 'Next' (Fig. 51 /2).

⇒ The software searches for an access point.

4. ▶ Select the air handling unit.

⇒ The 'Local Area Connection Status' window opens.

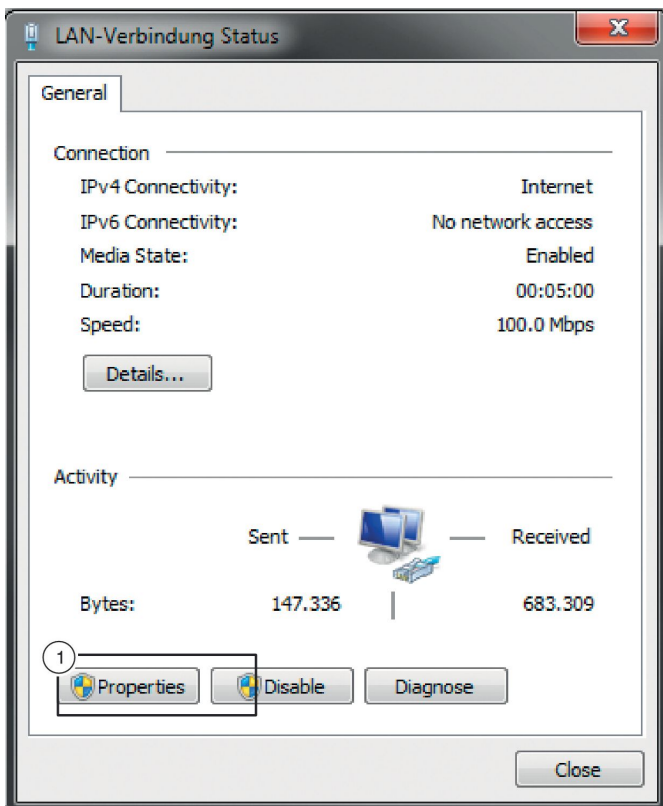

Fig. 52: LAN connection status

5. ▶ Select 'Properties' (Fig. 52 /1).

⇒ The 'Local Area Connection Properties' window opens.

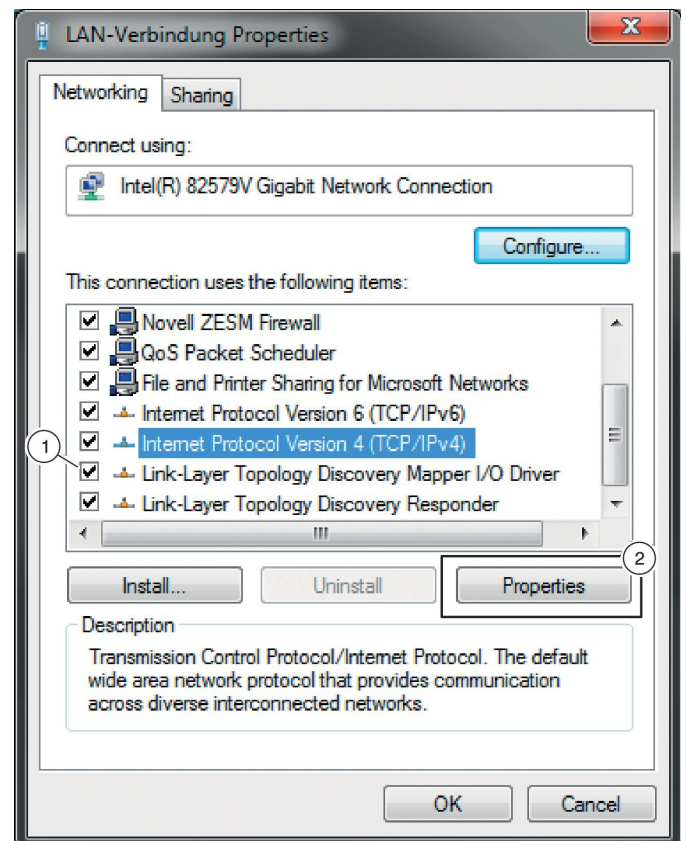

Fig. 53: LAN connection properties

6. ▶ Select 'Internet Protocol Version 4 (TCP/IPv4)' (Fig. 53 /1), then click on the 'Properties' (Fig. 53 /2) button.

⇒ The 'Internet Protocol Version 4 (TCP/IPv4) Properties' window opens.

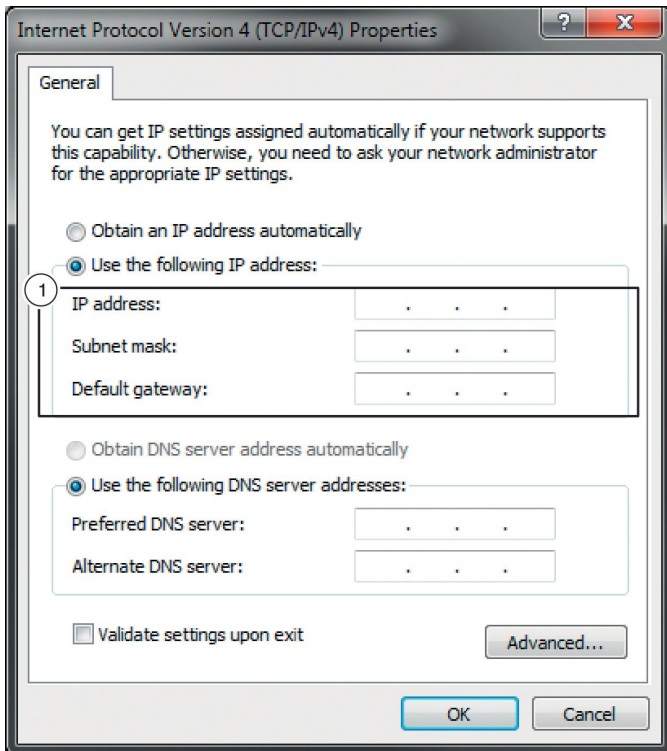

Fig. 54: Internet protocol properties

7. ▶ Select the 'Use the following IP address:' (Fig. 53 /1) option, enter the IP address, subnet mask and default gateway and confirm with 'OK'.
 - ⇒ The connection has been set up and the air handling unit can be operated using the web browser.

Restart the PC if necessary.

6.6 Logging in to the web server

Personnel:

- HVAC technician

There are three login levels to access the web server. Each level has different access rights for operating, maintenance or configuration functions.

Level	User name	Pass-word	Function
User	USER	0001	Setpoints
Installer	INSTALLER	0022	Setpoints and control settings

Level	User name	Pass-word	Function
Maintenance	SERVICE	0333	Service parameters

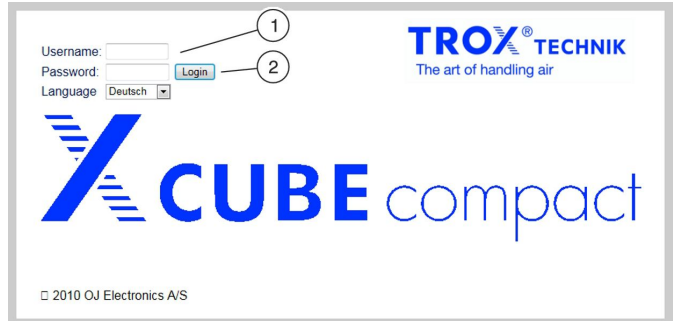

Fig. 55: Logging in to the web server

1. ▶ Enter your user name (Fig. 55 /1).
2. ▶ Enter your password.
3. ▶ Select 'Login' (Fig. 55 /2).
 - ⇒ You are now logged in to the web server.

7 Disassembly and disposal

7.1 Safety notes regarding disassembly and disposal

Incorrect disassembly

DANGER!

Risk to life from incorrect assembly and disassembly!

Incorrect assembly or disassembly can result in risks to life and limb and in environmental hazards.

- Before you start disassembly, professionally disconnect all electrical cables.
 - Only a skilled qualified electrician must disconnect the power supply.
 - Ensure that no voltage is present.
- Before you start disassembly, correctly drain all operating fluids.
 - Disconnect operating fluid pipes and hoses.
 - Ensure that operating fluids are disposed of correctly.
- If you have any questions regarding disassembly, refer to the assembly instructions in this manual. Pay attention to the component manufacturers' documentation.
- Only trained specialist personnel must remove any components.
- If necessary, use additional personal protective equipment for outdoor installations, e.g. a safety harness.

Improper transport equipment

WARNING!

Risk to life from using improper transport equipment!

If packages are lifted without adequate transport equipment and if they are not properly secured, they may fall off and lead to fatal injuries.

- Move components only in the position in which they are to be installed.
- Stand clear of suspended loads.
- Do not move additional loads on top of a package.
- Use only the intended lashing points.
- Make sure that no load is imposed on pipes, ducts or cables.
- Use only approved lifting gear and slings that are suitable and sufficient for the load to be carried.
- Do not tie ropes and chains or make knots or place them on sharp edges.
- Use lifting equipment only to lift packages or units, not to push or pull them.
- Ensure that ropes, belts and chains do not twist.
- Ensure that transport equipment has been correctly assembled, fastened and secured before you use it to lift anything.
- Secure all doors, dampers and panels.
- Move packages without any jerky movements and put them down when you leave your workplace.
- Lifting eyes are designed for one-time use only and not for permanently suspending loads.
- Transport tubes are designed for one-time use only and not for permanently suspending loads.

 2.3.1 'Residual risks' on page 11

Unbalanced loads and centre of gravity

WARNING!

Risk of injury from falling or toppling loads!

Loads may be unbalanced, i.e. the centre of gravity may not be obvious. If the load is not properly attached to the lifting equipment, it may topple and fall. Falling or toppling loads can cause serious injuries.

- When you use a crane to move loads, ensure that the centre of gravity of the load is directly beneath the crane hook.
- Lift any load carefully and keep an eye on it to see whether it will stay in place. If required, change the lashing point(s).

Crushing hazard!

 **WARNING!****Crushing hazard from movable parts!**

There is an increased risk of crushing on casing units, doors, panels and components of the device.

- Never reach between moving parts.
- Be careful when carrying out any work.
- Wear protective gloves, safety shoes and a hard hat.

Inspection access doors slamming shut

 **WARNING!****Risk of crushing from doors slamming shut**

Inspection access doors may slam shut by the wind or if someone pushes them inadvertently, resulting in serious injury to the head and limbs.

- Secure each inspection access door with a hold open device.
- Secure inspection access doors without a hold open device against closing by suitable means.
- Do not reach between the door and door frame.
- Wear protective gloves and a hard hat when you open an inspection access door.

Sharp edges, sharp corners and thin sheet metal parts

 **CAUTION!****Danger of injury from sharp edges, sharp corners and thin sheet metal parts!**

Sharp edges, sharp corners and thin sheet metal parts of the heat exchanger or of the cooling or heating coil may cause cuts or grazes.

- Be careful when working on these components.
- Wear protective gloves, safety shoes and a hard hat.

 **ENVIRONMENT!****Risk of harm to the environment due to incorrect disposal!**

Incorrect disposal may harm the environment.

- Have electronic waste, electronic components and operating fluids (refrigerant, compressor oil, lubricants etc.) disposed of by an approved specialist disposal company.

7.2 Dismantling

Personnel:

- HVAC technician
- Skilled qualified electrician

Protective equipment:

- Industrial safety helmet
- Protective clothing
- Hearing protection
- Protective gloves
- Safety shoes

1. ▶ Disconnect electrical cables.
Ensure that no voltage is present.
2. ▶ Remove all operating fluids.
Properly dispose of all operating fluids.
3. ▶ Disconnect operating fluid pipes and hoses.
4. ▶ Open all module connectors and base frame connectors.
5. ▶ Remove the various unit components.
Use suitable transport equipment to move unit components away from the site.

7.3 Disposal

If no return or disposal agreement is in place, any disassembled components should be disposed of by an approved specialist disposal company.

Components that are no longer required should be recycled:

- Scrap the metals.
- Take plastic parts to be recycled.
- Dispose of other components and waste in a suitable manner, i.e. depending on their material properties.

Electrical and electronic components

Electrical and electronic components can contain materials and substances that are hazardous to health and the environment and which must not get into household and commercial waste.

As electrical and electronic components may also contain recyclables (e.g. precious metals), they must be provided for recycling or disposal by a specialist disposal company.

Chemicals

Chemicals (solvents, cleaning agents, operating fluids, etc.) affect the air, soil, water, and human health in various ways. In some cases, valuable substances can be extracted from them.

Chemicals must therefore not get into the air, soil, sewerage system, surface water or groundwater.

Commission an approved specialist disposal company to recover or dispose of chemicals.

Refrigerant R-410A/R32

Refrigerants may contain substances that are toxic and hazardous to the environment, or which release hazardous decomposition products. These must not be released into the environment. Commission a specialist disposal company to dispose of hazardous substances and materials.

Coolant, glycol

Coolants may contain substances that are toxic and pose a hazard to the environment. They must not be released into the environment. Commission a specialist disposal company to dispose of hazardous substances and materials.

Batteries

Battery components are toxic and pose a hazard to the environment. Batteries must not be disposed of with domestic waste. Batteries must only be disposed of by locally approved specialist companies.

Lubricants

Lubricants such as greases and oils contain toxic substances. They must not be released into the environment. Commission a specialist disposal company to dispose of hazardous substances and materials.

Compressor oil

Compressor oil must not enter sewerage systems or bodies of water. Commission a specialist disposal company to dispose of hazardous substances and materials.

8 Glossary

Exhaust air – EHA

Air that flows from an internal space to the outside.

Extract air – ETA

Air that flows out of a conditioned room.

HVAC technician

HVAC technicians are individuals who have sufficient professional or technical training in the field they are working in to enable them to carry out their assigned duties at the level of responsibility allocated to them and in compliance with the relevant guidelines, safety regulations and instructions. HVAC technicians are individuals who have in-depth knowledge and skills related to HVAC systems; they are also responsible for the professional completion of the work under consideration.

Indoor air – IDA

Air in a conditioned internal space.

ODA – Outdoor air

Untreated air that flows through an inlet into the air handling unit or a building.

Recirculated air – RCA

Extract air that is reconditioned in the air handling unit and supplied to an internal space again.

Secondary air – SEC

Air that is conditioned and then supplied to the same room from which it was extracted.

Skilled qualified electrician

Skilled qualified electricians are individuals who have sufficient professional or technical training, knowledge and actual experience to enable them to work on electrical systems, understand any potential hazards related to the work under consideration, and recognise and avoid any risks involved.

Skilled qualified refrigeration technicians

Skilled qualified refrigeration technicians have been trained in the field of refrigeration engineering, and they know the relevant standards and guidelines. Evidence of the relevant experience claimed must be available. Skilled qualified refrigeration technicians are individuals who have sufficient professional or technical training, knowledge and actual experience to enable them to work on refrigeration systems, understand any potential hazards related to the work under consideration, and recognise and avoid any risks involved.

Supply air – SUP

Air that is supplied to a conditioned internal space; it is also conditioned air that enters an air handling unit.

Transfer air – TRA

Air that flows from one conditioned internal space to another conditioned internal space.

9 Index

A

Accident.....	13
Adjusting multileaf dampers.....	59
AHU	
Commissioning.....	54
Installing accessories.....	30
AHU casing units	
Applying sealing tape.....	28
Assembling AHU casing units for outdoor installation.....	28
Assembling the roof segments.....	28
Fixing.....	25
Installing ducts.....	29
Installing the noise insulating connector.....	27
Joining with screws/bolts.....	25
Seals, checking.....	23
Setup.....	23
Air handling unit	
Electrical connection.....	52
Applying sealing tape.....	28
Assembling the roof segments.....	28
Assembly	
Accessory module.....	30
AHU casing units for outdoor installation.....	28
Assembling AHU casing units.....	25
Ducts.....	29
Noise insulating connector.....	27
Roof segments.....	28

C

Calculate height of drain trap.....	35
Commissioning the centrifugal fan.....	55
Condensate drain.....	36
Connecting a drain trap.....	36
Cooling coil	
Commissioning.....	57
Installing.....	37
Copyright.....	3

D

Defects liability.....	3
Delivery of the air handling unit.....	14
Disassembly and disposal.....	68

E

Electric air heater	
Commissioning.....	58
Electrical connection.....	52
Electric current.....	12
Environmental protection	
Chemicals.....	69
Electrical and electronic components.....	68

F

Fan.....	12
Filters, inserting.....	57
Fire.....	13
First aid.....	13

H

Hazardous area.....	13
Heating coil	
Commissioning.....	57
Installing.....	37
Hotline.....	3

I

Improper transport equipment.....	15
Initial commissioning.....	54
Centrifugal fan.....	55
Electric air heater.....	58
Filters.....	57
Heating coil/cooling coil.....	57
Multileaf dampers.....	59
Plate heat exchanger.....	60
Rotary heat exchanger.....	60
Sound attenuator.....	59
Switching on.....	63

Installation

Calculate height of drain trap.....	35
Condensate drain.....	36
Connecting a drain trap.....	36
Connecting the heating coil/cooling coil.....	37
Connection to the central BMS.....	52
Network connection.....	52
Steam heat exchanger, connecting.....	39

Installation location, requirements

Installation room.....	22
Installing accessories.....	30
Installing ducts.....	29
IP address.....	63

L

Limitation of liability.....	3
Logging in to the web server.....	66

N

Noise.....	13
------------	----

O

Other applicable documentation.....	3
-------------------------------------	---

P

Packages	
Storage.....	18
Transport.....	16
Unpacking.....	19

Packaging, disposal.....	19	Switching on.....	61
Personnel.....	10	Symbols.....	4
Plate heat exchanger.....	60	On the packaging.....	14
Q		System owner.....	10
Qualification.....	10	System owner's obligations.....	10
R		T	
Requirements		Technical Service.....	3
Initial commissioning.....	54	Transport	
Installation.....	34	Crane and transport tubes.....	17
Switching on.....	61	Delivery.....	14
Requirements for the installation location		Delivery check.....	14
Foundation of the outdoor installation area.....	22	Forklift or pallet truck.....	16
Installation room.....	21	Transport damage.....	14
Installation room, foundation.....	21	Transport protection.....	19
Residual risks.....	11	Transport straps.....	19
Rotary heat exchanger.....	60	Transport tubes.....	19
Setting up the drive equipment.....	60	U	
S		Unpacking.....	19
Service.....	3	V	
Setting up network communication.....	64	Vibration insulation.....	22
Setup and assembly.....	20	W	
Sound attenuator.....	59	Warranty claims.....	3
Specific hazards.....	11	Wiring.....	40
Steam heat exchanger		X	
Installing.....	39	X-CUBE.....	6
Storage.....	18	X-CUBE components.....	6
Structure-borne sound decoupling.....	22	X-CUBE controller communication, setup.....	63
Suspended loads.....	11		

Appendix

A Circuit diagrams for electric air heaters

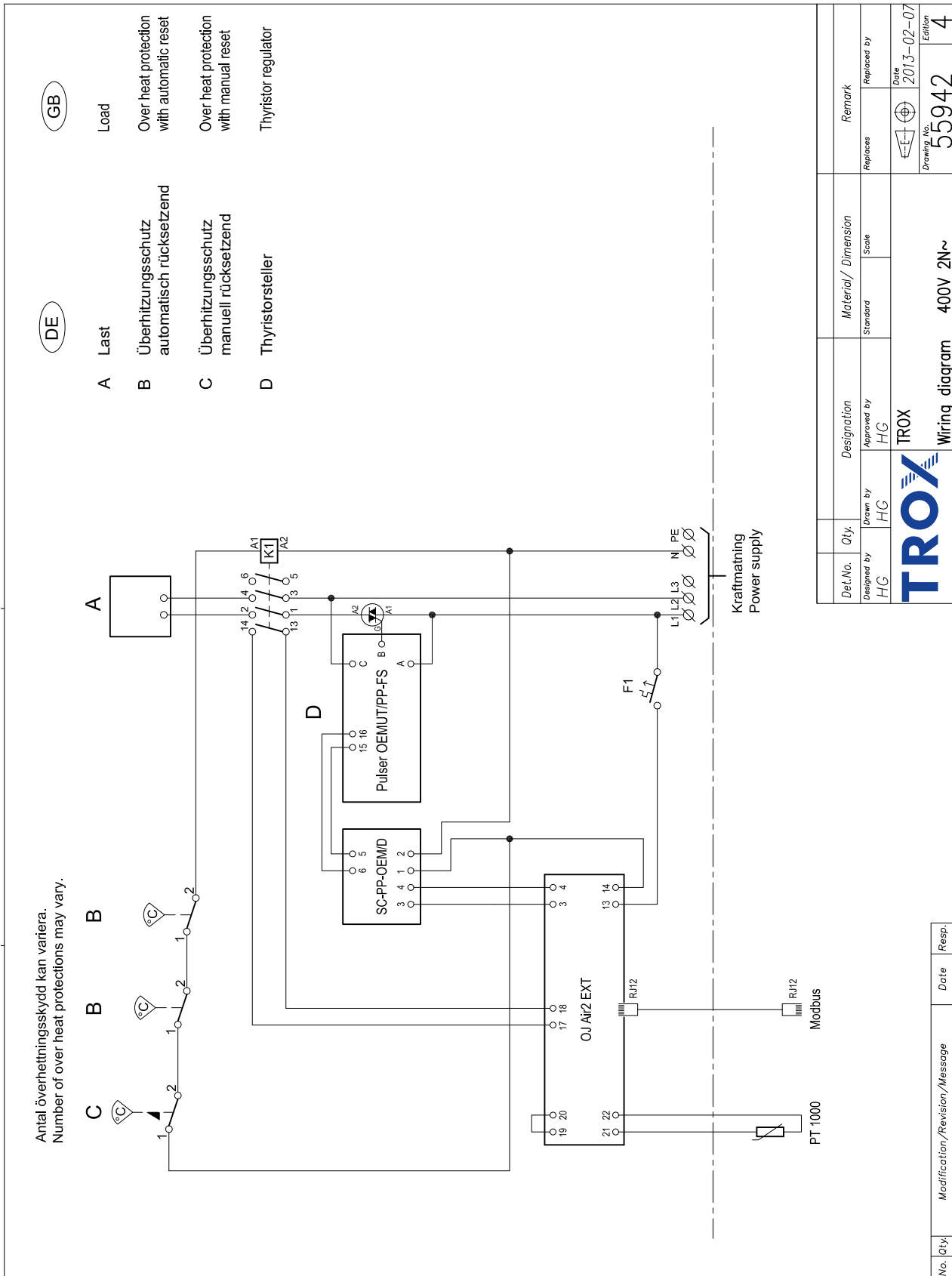
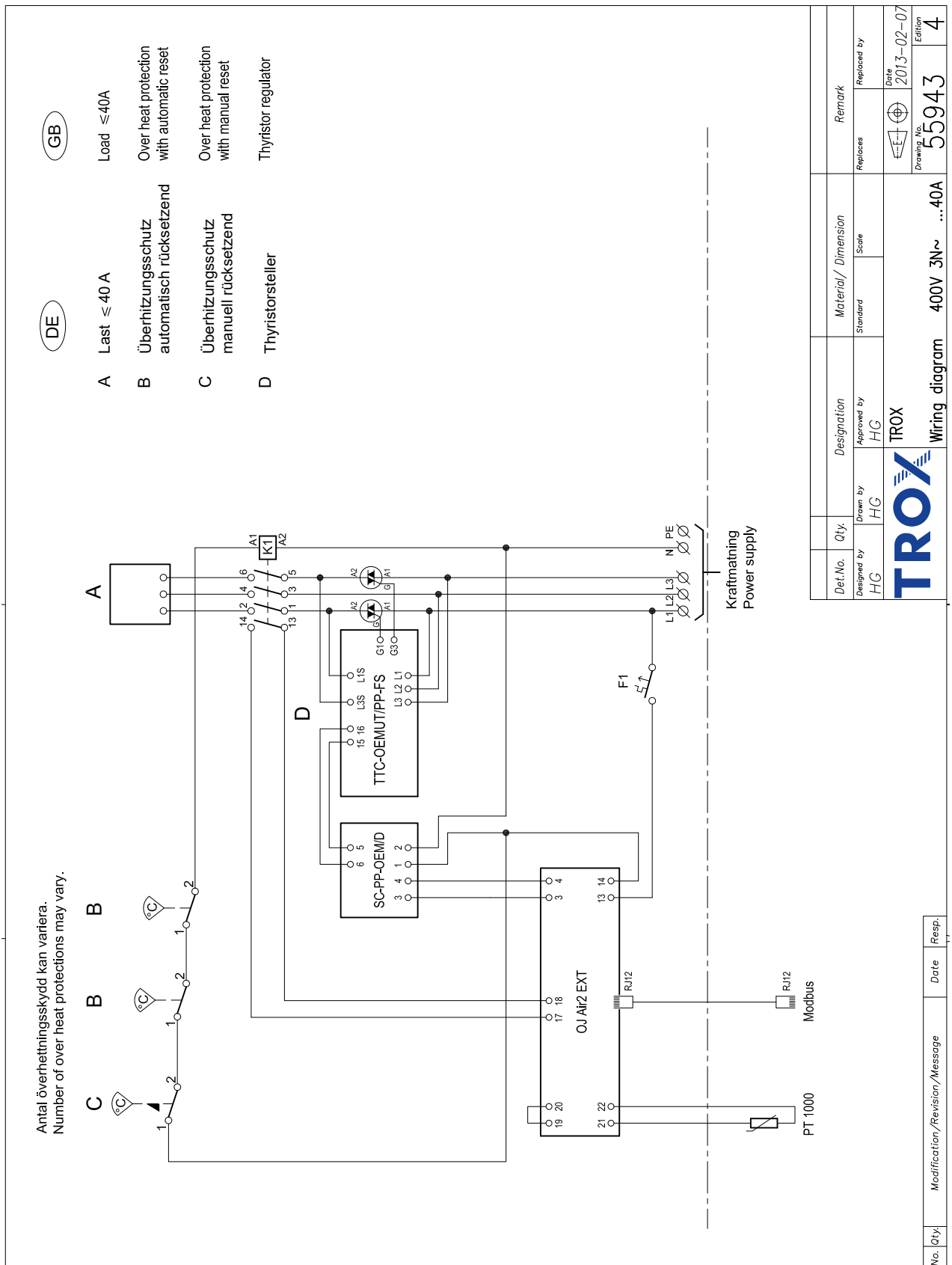

Fig. 56: Circuit diagram 55942



Det.No.	Qty.	Designation	Material/ Dimension	Remark
Designed by HG	Drawn by HG	Approved by HG	Standard	Replaces
			Scale	Date 2013-02-07
Wiring diagram			400V 3N~ ...40A	Drawing No. 55943
No. Qty.	Modification/Revision/Message	Date	Resp.	Edition 4

Fig. 57: Circuit diagram 55943

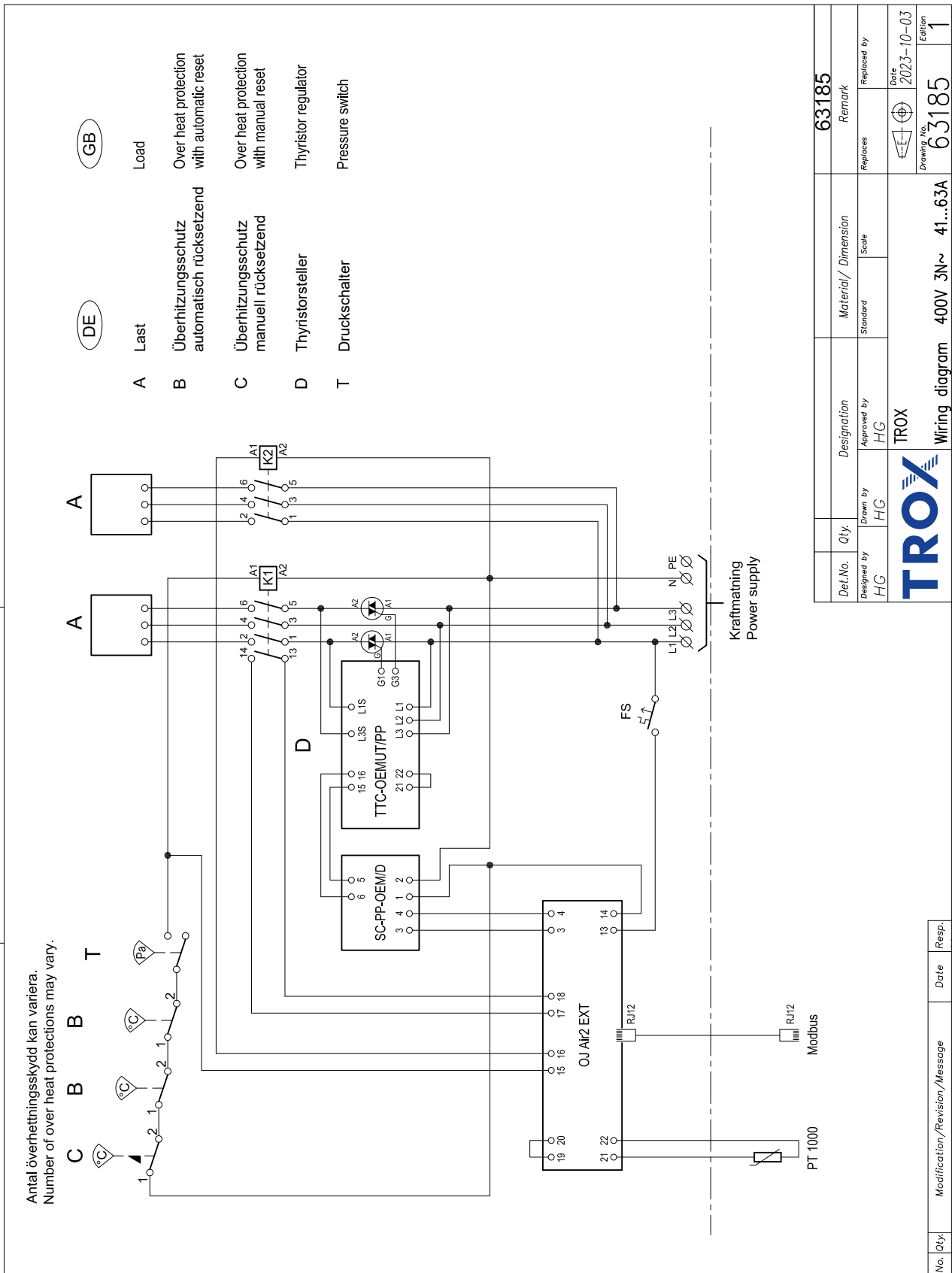

Fig. 58: Circuit diagram 63185

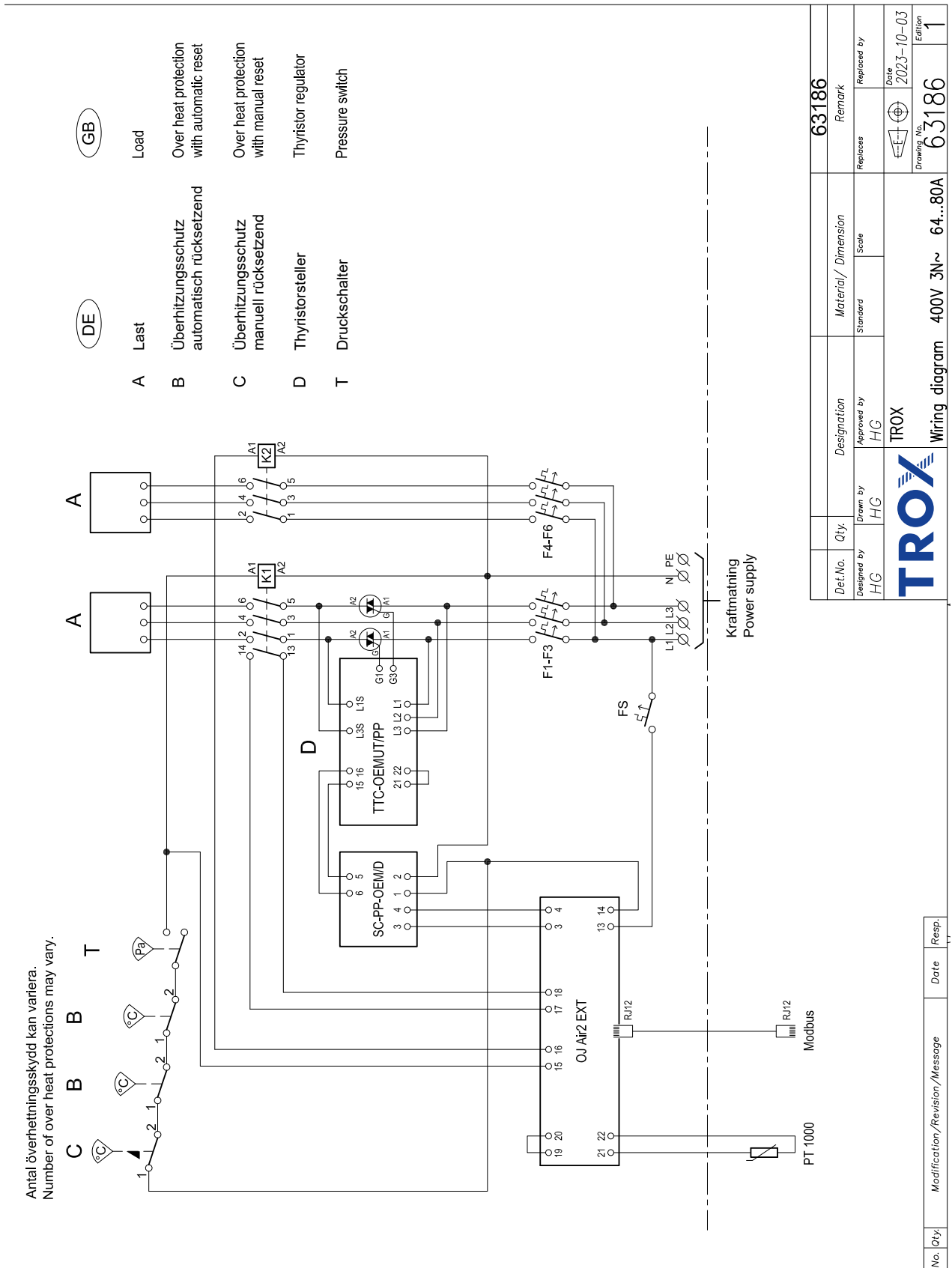

Fig. 59: Circuit diagram 63186

TROX[®] TECHNİK

The art of handling air

TROX GmbH
Heinrich-Trox-Platz
47504 Neukirchen-Vluyn
Germany

Phone: +49 2845 202-0
+49 2845 202-265
Email: trox-de@troxgroup.com
<http://www.troxtechnik.com>

© TROX GmbH 2022