

Thermal actuator with shape memory alloy



Discharge angle indicator



TJN with swirl unit and cap for throw distance reduction



TJN in white, similar to RAL 9010



TJN with outer casing

Nozzles

TJN

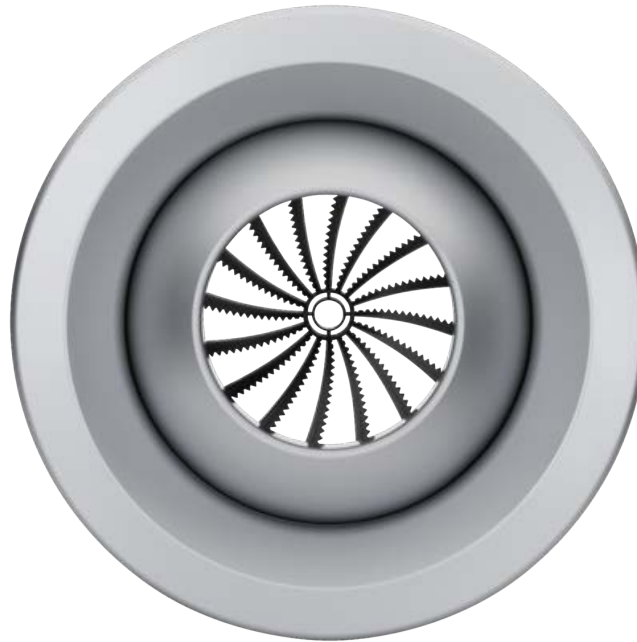

Jet nozzle made of plastic, acoustically and technically adjustable

The new TJN jet nozzle offers improved acoustic characteristics and is also more energy-efficient

- Nominal sizes: 160, 200, 250, 315 and 400 mm
- Volume flow rate range 20 – 1000 l/s or 72 – 3600 m³/h
- Visible parts made of high-grade polymer in white aluminium or pure white
- Optimised nozzle contours
- Discharge angle indication, discharge angle limiting and setting -30 – +30 on a concealed scale
- Easy-to-remove face cover ring with bayonet fixing

Optional equipment and accessories

- 5 nominal sizes, each with a circular spigot or, as an option, with a connection piece for circular or rectangular ducts
- Swirl unit with acoustically optimised air control blades with unique saw tooth edges and cap for two-step reduction of the throw distance
- External electric actuator of compact height
- Electric actuator allows for integration with the central BMS
- Internal thermal actuator with shape memory alloy for the self-powered adjustment of the discharge angle
- All variants also available with outer casing

General information	2	Variants	9
Function	3	Dimensions	15
Technical data	6	Product details	19
Quick sizing	6	Installation details	20
Specification text	7	Nomenclature	22
Order code	8		

General information

Application

- Jet nozzles as supply air diffuser, with a long throw distance
- For production halls, gymnasiums, theatres and conference rooms as well as for large internal spaces in airports, railway stations and shopping centres
- Attractive design element for building owners and architects with demanding aesthetic requirements
- For supply air to room air temperature differences from -12 – +20 K
- Adjustable discharge angle, from -30 - +30°, for switching between heating and cooling mode
- For push fitting directly onto circular ducts or as a branch off circular or rectangular ducts

Special characteristics

- Easy-to-remove face cover ring with bayonet fixing
- Swirl unit with acoustically optimised air control blades with unique saw tooth edges and cap for two-step reduction of the throw distance
- Discharge angle indication, discharge angle limiting and setting -30 – +30 on a concealed scale
- Electric or thermal actuator as options

Nominal sizes

- 160, 200, 250, 315, 400 mm

Variants

Connection

- Duct connection (direct connection)
- K: for rectangular ducts
- R: for circular ducts

Actuator

- Manual adjustment
- E*: electric actuator
- T1: thermal actuator

Parts and characteristics

- Nozzle with acoustically optimised contours and adjustable discharge angle from -30 - +30°, in increments of 5°
- Flange with position indicator (scale) and adjustable end positions, concealed by a face cover ring
- Spherical nozzle casing with spigot
- Outer casing (optional)
- Connection piece for circular and rectangular ducts (optional)
- Actuator (optional)

Attachments

- C: outer casing

Accessories

- Swirl unit and cap for throw distance reduction

Construction features

- Spigot suitable for circular ducts to EN 1506 or EN 13180
- Spigot with double lip seal

Materials and surfaces

- Flange frame, face cover ring, nozzle, swirl unit and cap made of ABS plastic, UL94, V-0, flame retardant
- Spherical nozzle casing made of galvanised sheet steel
- Connection pieces for circular and rectangular ducts made of galvanised sheet steel
- Double lip seal made of rubber
- Exposed surface is pure white, similar to RAL 9010
- S1: white aluminium, similar to RAL 9006

Standards and guidelines

- Sound power level of the air-regenerated noise measured according to EN ISO 5135

Maintenance

- Low-maintenance, as construction and materials are not subject to wear
- Inspection and cleaning to VDI 6022

Disclosure of Chemicals

- RoHS EU Directive 2011/65/EU (RoHS)
 - This product or single variants comply with EU Directive 2011/65/EU (RoHS) on the restriction of the use of certain hazardous substances in electrical and electronic equipment. For more information, please refer to our Environmental Product Declarations.
- REACH 1907/2006 (EC Regulation REACH)
 - This product or single variants comply with the provisions of EC Regulation No. 1907/2006, also known as REACH (Registration, Evaluation, Authorisation and Restriction of Chemicals). For more information, please refer to our Environmental Product Declarations.

Function

Jet nozzles are the preferred solution wherever the supply air has to travel large distances from the point of discharge to the occupied zone. It is possible to adapt the discharge angle, and consequently the direction of the airflow, to heating or cooling mode. The supply air to room air temperature difference can be -12 - +20 K.

Cooling mode

Cooling mode is possible with a positive discharge angle of up to 30°. The supply air jet is directed towards the ceiling, but the higher density of cold air results in an increasing deflection of the air jet towards the floor as the distance from the jet nozzle increases. When the supply air jet reaches the occupied zone, both the supply air to room air temperature difference and the airflow velocity have been reduced to comfortable levels. This principle of operation allows for long throw distances.

Heating mode

Heating operation is possible with a negative discharge angle of -30° or less. The supply air jet is directed towards the occupied zone. Due to the lower density of warm air, the jet becomes buoyant. When the supply air jet reaches the occupied zone, both the supply air to room air temperature difference and the airflow velocity should ideally have been reduced.

The discharge angle can be changed manually or with a thermal or electric actuator.

A swirl unit and cap (optional) allow for reducing the throw distance to 65 % or 75 %.

Schematic illustration of TJN

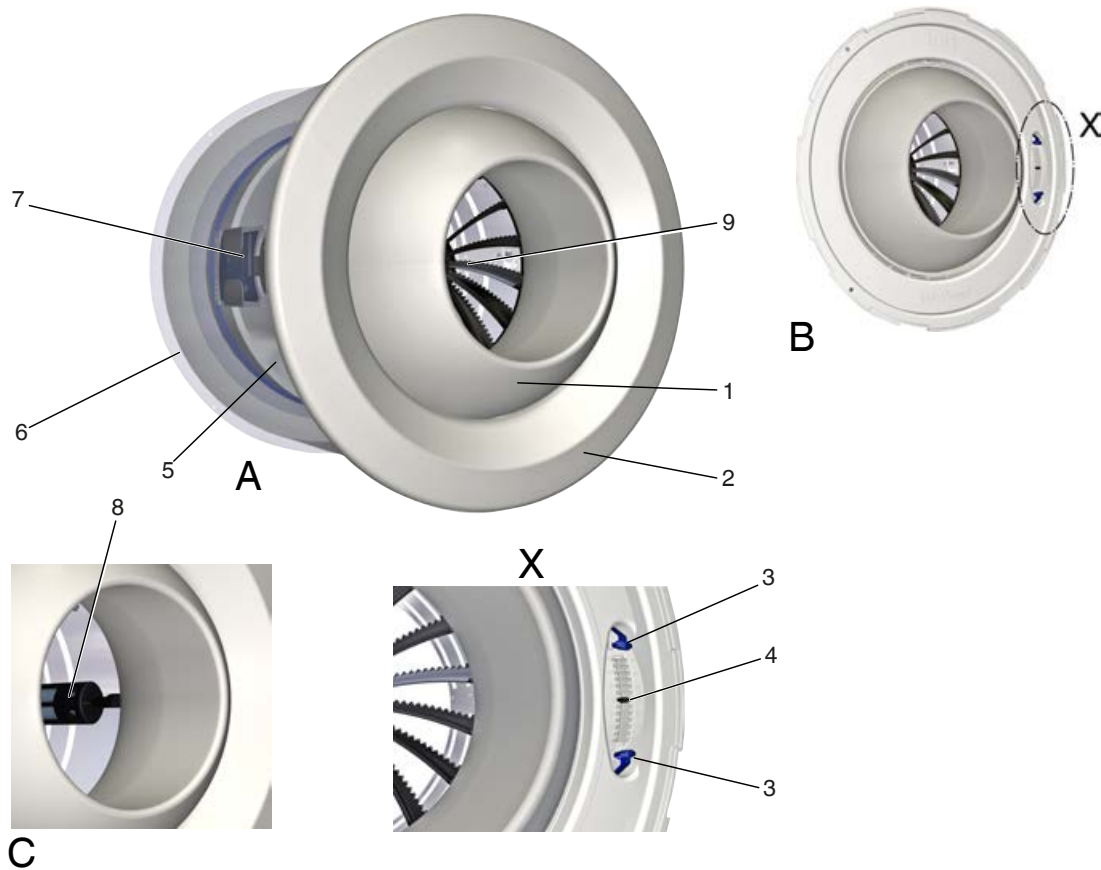

- A TJN-E*
- B TJN, with the face cover ring removed
- C TJN-T1
- 1 Nozzle
- 2 Face cover ring
- 3 End position, adjustable
- 4 Position indicator
- 5 Spherical nozzle casing

- Optional
- 6 Outer casing
- 7 Electric actuator
- 8 Thermal actuator
- 9 Swirl unit and cap

TJN air pattern in cooling mode

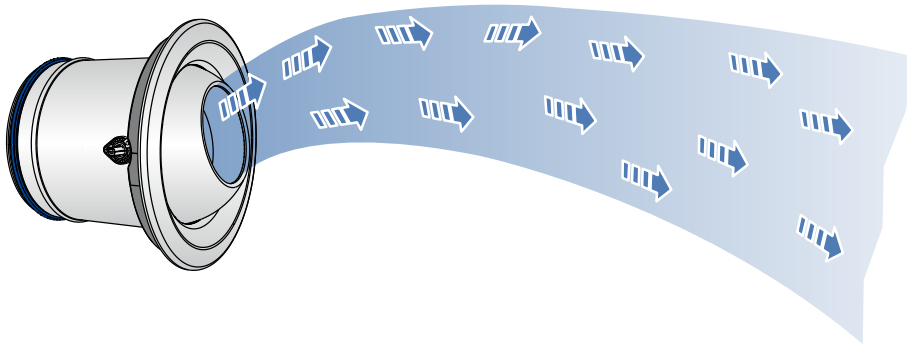

TJN air pattern in heating mode

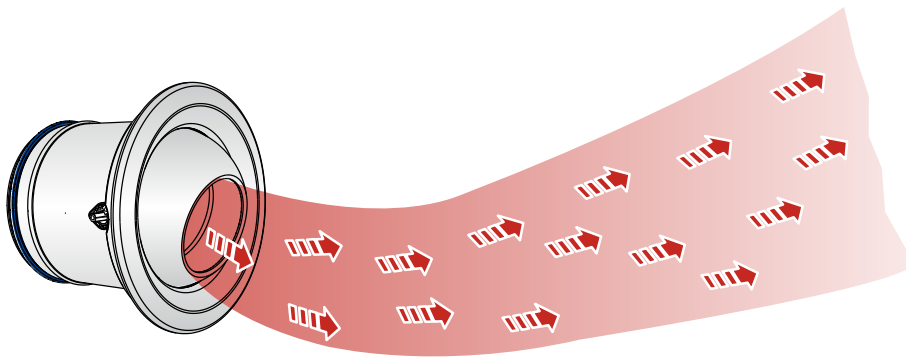

TJN air pattern with isothermal ventilation

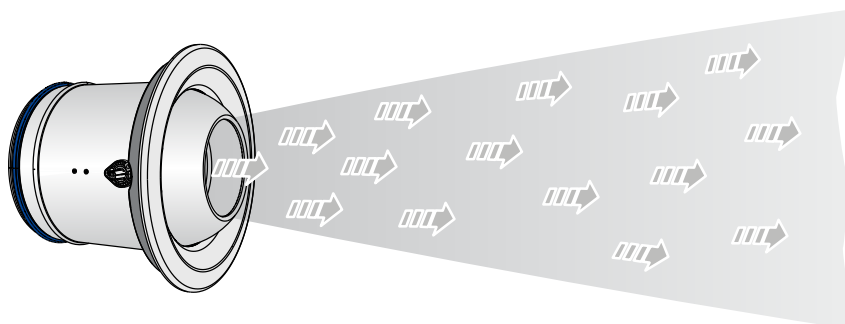

TJN air pattern with vertical discharge, heating mode

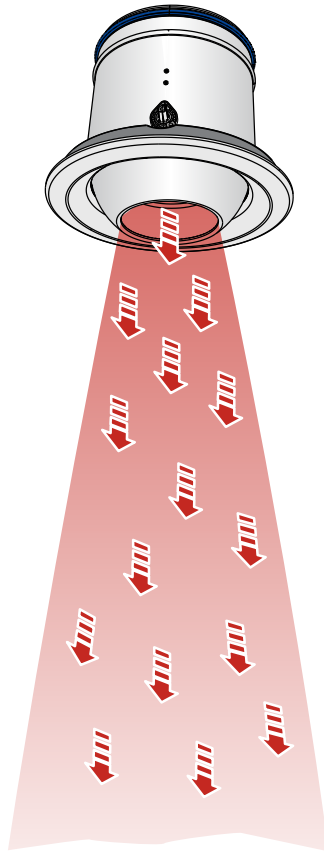

Technical data

Nominal sizes	160, 200, 250, 315, 400 mm
Volume flow rate range	20 – 1000 l/s or 72 – 3600 m ³ /h
Adjustable discharge angle	-30 – +30°
Supply air to room air temperature difference	-12 to +20 K

Quick sizing

Quick sizing tables provide a good overview of the volume flow rates and corresponding sound power levels and differential pressures.

Exact values for all parameters can be determined with our Easy Product Finder design program.

Sound power level and total differential pressure

NS	q _v [l/s]	q _v (m ³ /h)	Δp _t [Pa]	LWA [dB(A)]	v _L	
					0.5 m/s	1.0 m/s
					L [m]	L
160	20	72	9	< 15	< 5	< 5
	40	144	34	< 15	8	< 5
	60	216	76	15	13	6
	80	288	135	26	17	8
200	35	126	9	< 15	6	< 5
	70	252	35	< 15	11	6
	105	378	78	19	17	9
	140	504	138	30	23	11
250	55	198	8	< 15	7	< 5
	110	396	33	< 15	14	7
	165	594	75	21	21	11
	220	792	132	33	28	14
315	90	324	8	< 15	9	< 5
	185	666	35	< 15	18	9
	265	954	71	24	26	13
	360	1296	132	36	> 30	18
400	155	558	8	< 15	12	6
	310	1116	33	< 15	24	12
	465	1674	75	27	> 30	18
	620	2232	133	38	> 30	24

All values apply to discharge angle 0°

L: Throw distance with isothermal operation, no throw distance reduction

Specification text

This specification text describes the general properties of the product. Texts for variants can be generated with our Easy Product Finder design programme.

Adjustable jet nozzles for the ventilation of large internal spaces such as halls and assembly rooms. Air discharge with long throw distance, excellent acoustic properties. Nozzles tilt vertically from -30 - $+30^\circ$ for horizontal air discharge. Discharge angle indication, discharge angle limiting and setting on a concealed scale.

Consists of a casing for the spherical discharge nozzle, flange, face cover ring and nozzle.

For push fitting directly onto circular ducts or as a branch off circular or rectangular ducts.

Special characteristics

- Easy-to-remove face cover ring with bayonet fixing
- Swirl unit with acoustically optimised air control blades with unique saw tooth edges and cap for two-step reduction of the throw distance
- Discharge angle indication, discharge angle limiting and setting -30 – $+30$ on a concealed scale
- Electric or thermal actuator as options

Maintenance

- Low-maintenance, as construction and materials are not subject to wear
- Inspection and cleaning to VDI 6022

Materials and surfaces

- Flange frame, face cover ring, nozzle, swirl unit and cap made of ABS plastic, UL94, V-0, flame retardant
- Spherical nozzle casing made of galvanised sheet steel
- Connection pieces for circular and rectangular ducts made of galvanised sheet steel
- Double lip seal made of rubber
- Exposed surface is pure white, similar to RAL 9010
- S1: white aluminium, similar to RAL 9006

Life cycle assessment

A life cycle assessment is available for the product type in the form of an environmental product declaration (EPD), which has been checked and published by a programme holder.

Order code

TJN-R-E7/160-315/C/D/S1

1	2	3	4	5	6	7	8

1 Type

TJN Adjustable jet nozzle

2 Connection piece

No entry: without connection piece

K For rectangular ducts

R For circular ducts (saddle connector)

3 Actuator

No entry: manual adjustment

E7 230 V AC, 3-point

E8 24 V AC/DC, 3-point

E9 24 V AC/DC, modulating, 2 – 10 V DC

T1 thermal actuator

4 Nominal size [mm]

160, 200, 250, 315, 400

5 Duct diameter [mm]

Applies only to circular ducts

315 (nominal size 160 only)

500 (up to nominal size 315 only)

630

800

6 Attachments

No entry: without attachments

C Outer casing

7 Accessories

No entry: without accessories

D Swirl unit and cap for throw distance reduction

8 Exposed surface

No entry: similar to RAL 9010 (pure white)

S1 Similar to RAL 9006 (white aluminium)

Order example: TJN-R-E7/160-315/C/D/S1

Type	TJN
Connection piece	For circular ducts (saddle connector)
Actuator	230 V AC, 3-point
Nominal size [mm]	160
Duct diameter [mm]	315
Attachments	Outer casing
Accessories	Swirl unit and cap for throw distance reduction
Exposed surface	Similar to RAL 9006 (white aluminium)

Order example: TJN-K-E9/250/C/S1

Type	TJN
Connection piece	For rectangular ducts
Actuator	24 V AC/DC, modulating, 2 – 10 V DC
Nominal size [mm]	250
Duct diameter [mm]	-
Attachments	Outer casing
Accessories	Without accessories
Exposed surface	Similar to RAL 9006 (white aluminium)

Variants

General information

Together with renowned designers and architects we have developed ceiling, wall, staircase and floor diffusers and grilles that are not only aesthetic design elements, but also meet demanding ventilation and acoustic requirements.

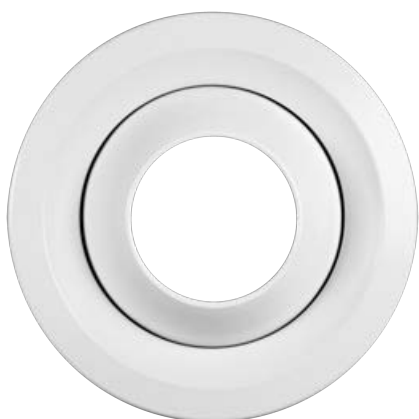
User interface
TJN

TJN in white, similar to RAL 9010

TJN/.../S1



TJN in white aluminium, similar to RAL 9006

Outer casing
TJN-K/.../C

TJN for connection to rectangular ducts, with outer casing

TJN-R/.../C



TJN for connection to circular ducts, with outer casing

Adjustment
TJN

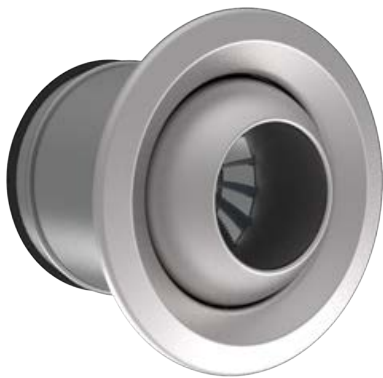

Manual adjustment

TJN-T1



Thermal actuator

TJN-E*



Electric actuator

Throw distance 100%

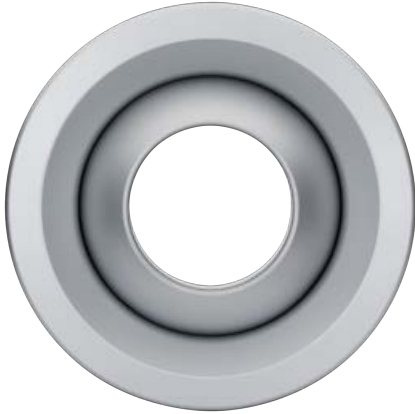

TJN without swirl unit

Throw distance 75%

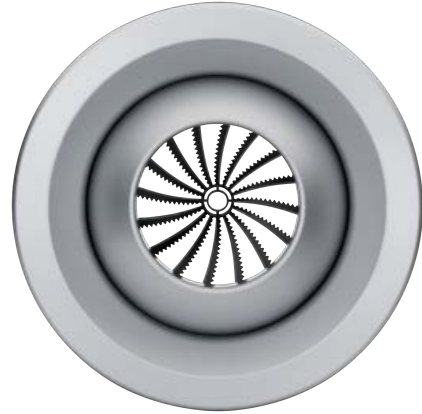

TJN with swirl unit for throw distance reduction

Throw distance 65%



TJN with swirl unit and cap for throw distance reduction

**Connection piece
TJN**

TJN for direct connection onto circular ducts

Variant

- Jet nozzle for the direct connection to circular ducts

Nominal sizes

- 160, 200, 250, 315, 400

Parts and characteristics

- Spherical nozzle casing for holding the nozzle with spigot

Construction features

- Spigot suitable for circular ducts to EN 1506 or EN 13180
- Spigot with double lip seal

TJN-K



TJN for connection to rectangular ducts, without outer casing

Variant

- Jet nozzle with connection piece for rectangular ducts

Nominal sizes

- 160, 200, 250, 315, 400

Parts and characteristics

- Connection piece for the connection to rectangular ducts

Construction features

- Connection piece with raised edges to be screw-fixed or riveted to the duct

TJN-R



TJN for connection to circular ducts

Variant

- Jet nozzle with connection piece for circular ducts

Nominal sizes

- 160, 200, 250, 315, 400

Parts and characteristics

- Connection piece (saddle connector) for the connection to circular ducts

Construction features

- Connection piece with raised edges to be screw-fixed or riveted to the duct
- Ducts with nominal diameter 315 can only be equipped with TJN nozzles size 160
- Ducts with nominal diameter 500 can only be equipped with TJN nozzles size up to an including 315

Dimensions

TJN

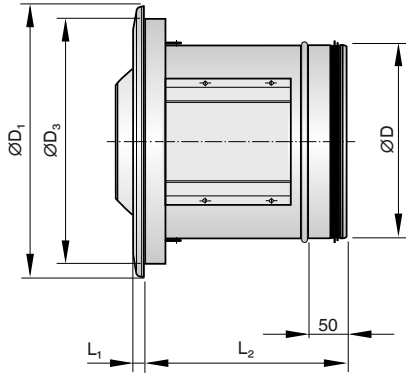

TJN

NS	TJN		TJN-E*		TJN-T1		ØD ₁	L ₁	ØD ₄	ØD	C
	L ₂	m [kg]	L ₂	m [kg]	L ₂	m [kg]					
160	242	1.9	242	2.1	302	2.3	258	15	227	158	50
200	250	2.3	250	2.5	310	2.8	298	14	263	198	50
250	260	3.1	260	3.3	320	3.7	348	14	315	248	50
315	275	4.0	275	4.2	335	4.8	413	15	379	313	50
400	285	4.6	285	4.8	345	5.5	501	16	468	398	50

TJN.../C

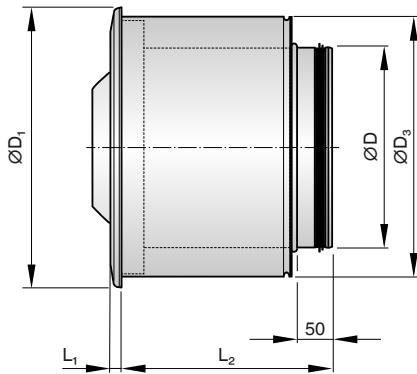

TJN.../C

NS	TJN.../C		TJN-E*.../C		TJN-T1.../C		ØD ₁	L ₁	ØD ₃	ØD	C
	L ₂	m [kg]	L ₂	m [kg]	L ₂	m [kg]					
160	242	2.7	242	2.9	302	3.4	258	15	228	158	50
200	250	3.4	250	3.6	310	4.2	298	14	265	198	50
250	260	4.4	260	4.6	320	5.3	348	14	316	248	50
315	275	5.8	275	6.0	335	7.0	413	15	381	313	50
400	285	8.0	285	8.2	345	9.5	501	16	469	398	50

TJN-K

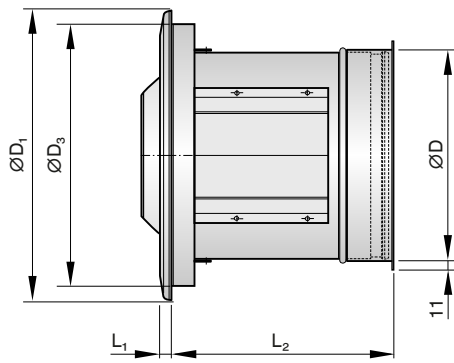

TJN-K

NS	TJN-K		TJN-K-T1		TJN-E*/.../C		$\varnothing D_1$	L_1	$\varnothing D_4$	$\varnothing D$	C
	L_2	m [kg]	L_2	m [kg]	L_2	m [kg]					
160	248	2.1	308	2.5	248	2.3	258	15	227	158	50
200	257	3.2	317	3.7	257	3.4	298	14	263	198	50
250	265	3.4	325	4.0	265	3.6	348	14	315	248	50
315	281	4.6	341	5.4	281	4.8	413	15	379	313	50
400	292	6.5	352	7.4	292	6.7	501	16	468	398	50

TJN-KI.../C

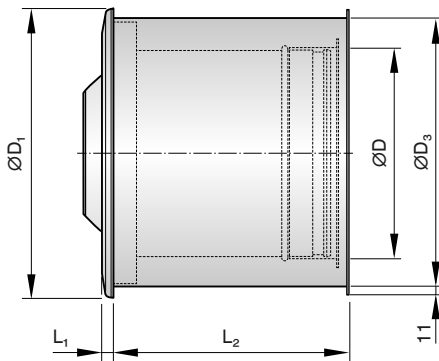

TJN-KI.../C

NS	TJN-KI.../C		TJN-K-E*/.../C		TJN-K-T1/.../C		$\varnothing D_1$	L_1	$\varnothing D_3$	$\varnothing D$	C
	L_2	m [kg]	L_2	m [kg]	L_2	m [kg]					
160	258	3.5	258	3.7	318	4.2	258	15	228	158	50
200	267	4.3	267	4.5	327	5.1	298	14	265	198	50
250	276	5.5	276	5.7	336	6.4	348	14	316	248	50
315	291	7.2	291	7.4	351	8.4	413	15	381	313	50
400	302	9.9	302	10.1	362	11.4	501	16	469	398	50

TJN-R

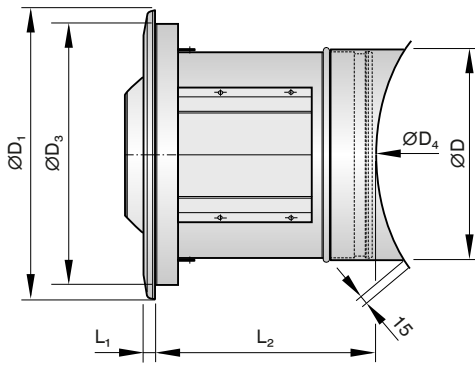

$\varnothing D_5$ Circular duct diameter

TJN-R

NS	TJN-R		TJN-R-E*		TJN-R-T1		$\varnothing D_1$	L_1	$\varnothing D_4$	$\varnothing D$	C
	L_2	m [kg]	L_2	m [kg]	L_2	m [kg]					
160	248	2.1	248	2.3	308	2.5	258	15	227	158	50
200	257	3.2	257	3.4	317	3.7	298	14	263	198	50
250	265	3.4	265	3.6	325	4.0	348	14	315	248	50
315	281	4.6	281	4.8	341	5.4	413	15	379	313	50
400	292	6.5	292	6.7	352	7.4	501	16	468	398	50

TJN-R/.../C

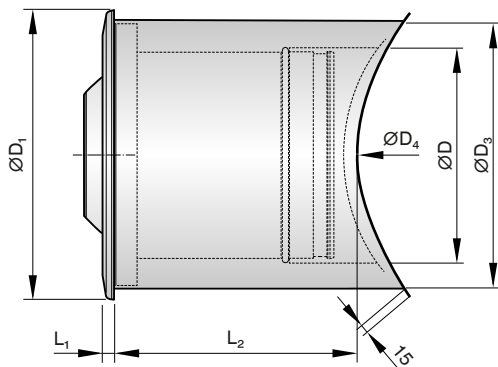

$\varnothing D_5$ Circular duct diameter

TJN-R/.../C

NS	TJN-R/.../C		TJN-R-E*/.../C		TJN-R-T1/.../C		$\varnothing D_1$	L_1	$\varnothing D_3$	$\varnothing D$	C
	L_2	m [kg]	L_2	m [kg]	L_2	m [kg]					
160	261	3.5	261	3.7	321	4.2	258	15	228	158	50
200	270	4.3	270	4.5	330	5.1	298	14	265	198	50
250	279	5.5	279	5.7	339	6.4	348	14	316	248	50
315	294	7.2	294	7.4	354	8.4	413	15	381	313	50
400	305	9.9	305	10.1	365	11.4	501	16	469	398	50

Circular duct dimensions ØD_s [mm]

NS	315	500	630	800
160	+	+	+	+
200		+	+	+
250		+	+	+
315		+	+	+
400			+	+

Product details

TJN front view

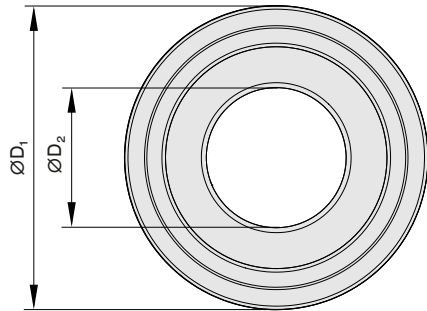

TJN

NS	ØD_1	ØD_2	$A_{\text{eff}} [\text{m}^2]$
160	258	82	0.00500
200	298	108	0.00850
250	348	136	0.0135
315	413	174	0.0225
400	501	231	0.0385

Installation details

Installation and commissioning

- The correct installation orientation is marked 'Top' on the flange
- Installation directly onto circular ducts or as a branch off circular or rectangular ducts
- If necessary, adjust the throw distance using the swirl unit, or the swirl unit and the cap

The illustrations are schematic and serve to create a better understanding of the installation details.

Installation in circular ducts, without outer casing

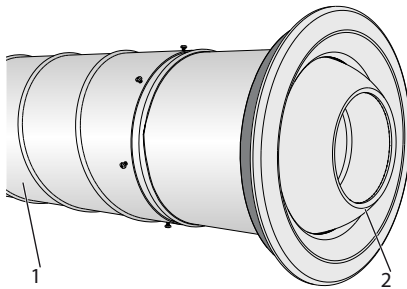

Installation in circular air ducts, with pipe connection spigot

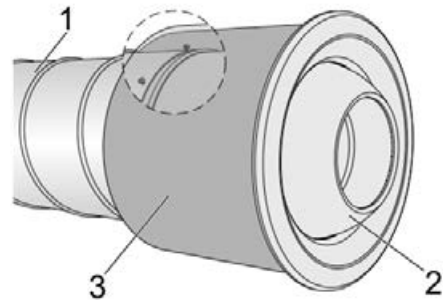

TJN, DUK-V

- 1 Circular duct
- 2 Jet nozzle

- 1 Circular duct
- 2 Jet nozzle
- 3 Spigot (axial)

Installation on rectangular ducts, without outer casing

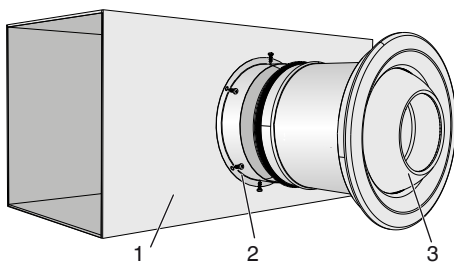

Installation on rectangular ducts, with outer casing

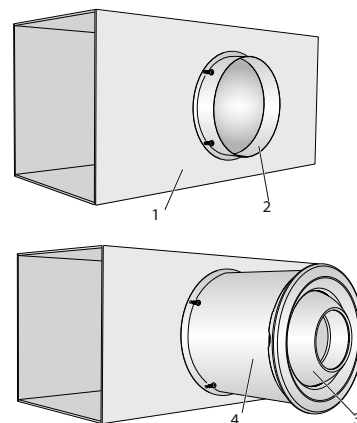

TJN-K, DUK-V-K

- 1 Rectangular duct
- 2 Spigot that fits onto rectangular ducts
- 3 Jet nozzle

TJN-K/.../C

- 1 Rectangular duct
- 2 Spigot that fits onto rectangular ducts
- 3 Jet nozzle
- 4 Outer casing

Installation on circular ducts, without outer casing

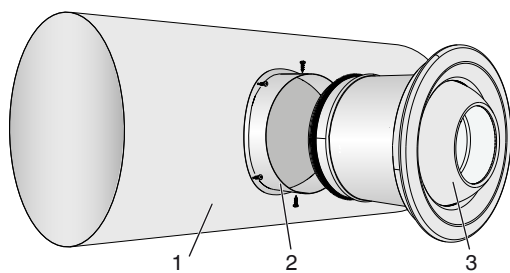

TJN-R, DUK-V-R

- 1 Circular duct
- 2 Saddle connector
- 3 Jet nozzle

Installation on circular ducts, with outer casing

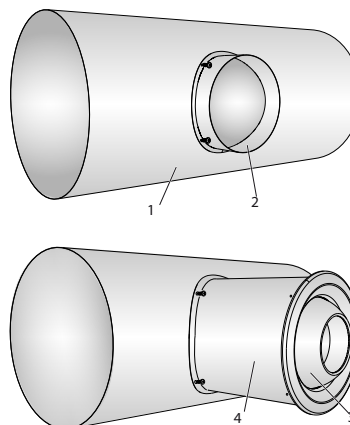

TJN-R/.../C

- 1 Circular duct
- 2 Saddle connector
- 3 Jet nozzle
- 4 Outer casing

Installation on a plane surface

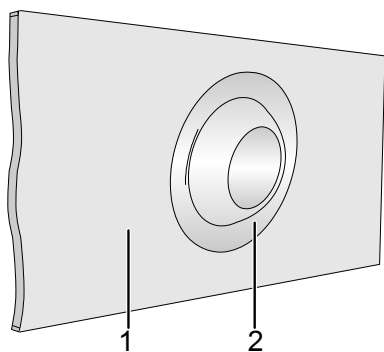

TJN, DUK-V

- 1 Plane installation surface
- 2 Jet nozzle

Nomenclature

 $\varnothing D_1$ [mm]

Outer diameter of the face cover ring

 $\varnothing D_2$ [mm]

Smallest nozzle diameter (at the discharge opening)

 $\varnothing D_3$ [mm]

Diameter of the nozzle casing

 $\varnothing D_4$ [mm]

Nominal width of the circular duct, for nozzles with saddle connector

 L_1 [mm]

Length of the face cover ring

 L_2 [mm]

Casing length

 m [kg]

Weight

 L_{WA} [dB(A)]

A-weighted sound power level of air-regenerated noise

 q_v [m³/h]; [l/s]

Volume flow rate

 Δt_z [K]

Supply air to room air temperature difference, i.e. supply air temperature minus room temperature

 Δp_t [Pa]

Total differential pressure

 v_L [m/s]

Air velocity at throw distance L (measured at the centre of the airflow)

 L [m]

Throw distance with isothermal operation, no throw distance reduction

 A_{eff} [m²]

Effective air discharge area

All sound power levels are based on 1 pW.

Lengths

All lengths are given in millimetres [mm] unless stated otherwise.