

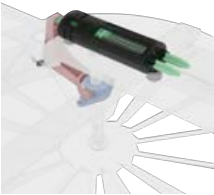

Circular diffuser face



Circular plenum



Internal thermal actuator

Ceiling Swirl Diffusers

RFD-V



With low sound power level for comfort and industrial zones, with fixed air control blades and variable internal geometry

- Circular swirl diffusers for exposed installation
- Nominal sizes 160, 200, 250, 315
- Volume flow rate range 9l/s – 195l/s or 32m³/h – 702m³/h
- For variable and constant volume flows
- Available in RAL CLASSIC colours
- Horizontal duct connection
- Plenum box with damper blade and pressure tap
- Internal thermal actuator

General information	2	Order code	6
Function	3	Dimensions	7
Technical data	4	Product details	8
Quick sizing	4	Nomenclature	11
Specification text	5		

General information

Application

Type RFD-V ceiling swirl diffusers are used as supply or extract air diffusers for comfort and industrial zones

Attractive design element for building owners and architects with demanding aesthetic requirements

Horizontal 360° supply air discharge for mixed flow ventilation

The efficient swirl creates high induction levels, thereby rapidly reducing the temperature difference and airflow velocity (supply air)

Designed for freely suspended applications

For variable and constant volume flows

For supply air to room air temperature differences -10 to +15 K

- P2: Powder-coated RAL9006, white aluminium, gloss level 30%
 - P4: Powder-coated RAL9005, jet black, gloss level 20%
 - P6: Powder-coated in any other RAL CLASSIC colour, gloss level 30%
- Plenum finish
- 0: Natural (unpainted)
 - P3: Powder-coated RAL9010, pure white, gloss level 20%
 - P2: Powder-coated RAL9006, white aluminium, gloss level 30%
 - P4: Powder-coated RAL9005, jet black, gloss level 20%
 - P6: Powder-coated in any other RAL CLASSIC colour, gloss level 30%

Special characteristics

Low sound power level, ideal for comfort zones

Fixed blades

Diaphragm for volume flow determination

Optional internal lining, closed or open cell

Internal thermal actuator (supply only)

Material and surfaces

- Diffuser face made of galvanised steel
- Discharge nozzle made of aluminium
- Plenum box, non-visible adjustment mechanism and cross bar made of galvanised sheet steel

Nominal sizes

160, 200, 250, 315

Standards and guidelines

- Sound power level of the air-regenerated noise measured according to EN ISO 5135

Construction

Diffuser face finish

P3: Powder-coated RAL9010, pure white, gloss level 20%

Maintenance

- Low maintenance as construction and materials are not subject to wear
- Inspection and cleaning to VDI 6022

Function

Ceiling diffusers direct the air from air conditioning systems into the room. The resulting airflow induces high levels of room air, thereby rapidly reducing the airflow velocity and the temperature difference between supply air and room air. Ceiling diffusers allow for large volume flow rates. The result is a mixed flow ventilation in comfort zones, with good overall room ventilation, creating only very little turbulence in the occupied zone.

Type RFD-V ceiling diffusers have fixed blades and an adjustable internal sleeve, allowing for horizontal and vertical air discharge. During cooling air discharge is horizontal and radial, in heating air discharge is vertical. The internal sleeve is controlled with a thermal actuator. The supply air to room air temperature difference may range from -10 to +15K. To give rooms an aesthetic, uniform look, type RFD-V diffusers may also be used for extract air.

Schematic illustration of the RFD-V

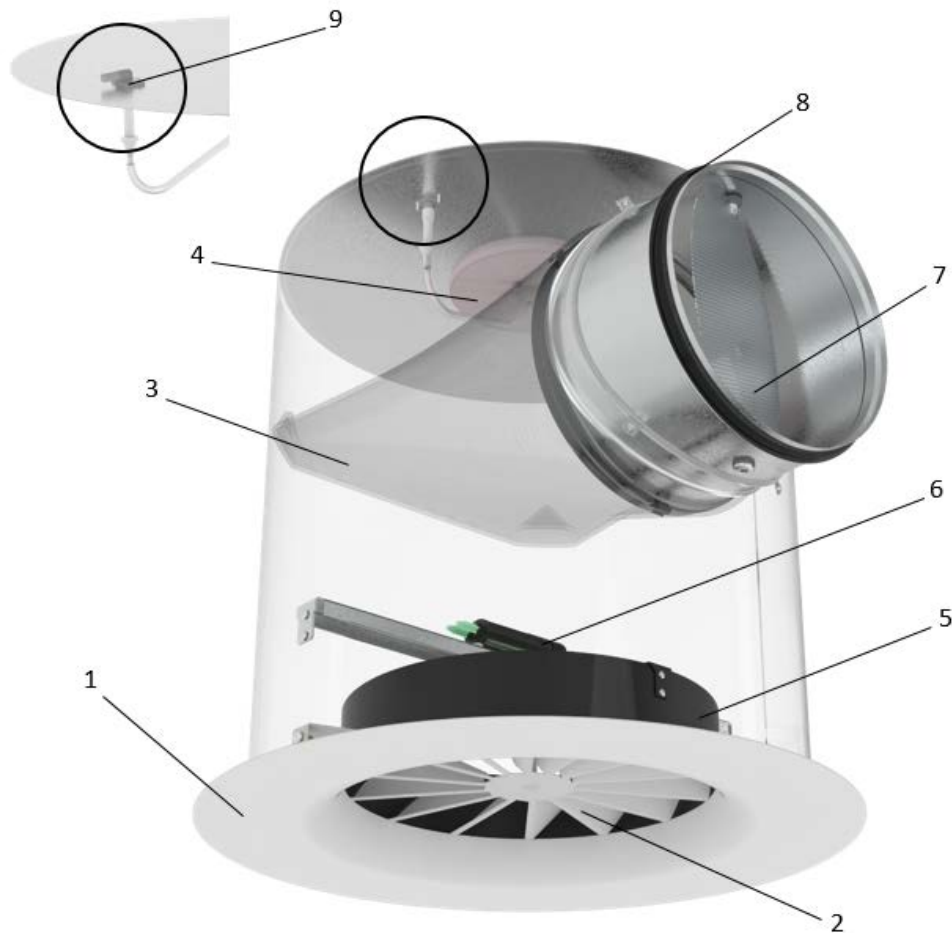

- 1 Discharge nozzle
- 2 Swirl element
- 3 Air distribution element
- 4 Pressure Diaphragm
- 5 Retractable sleeve
- 6 Thermal actuator
- 7 Spigot damper
- 8 Lip seal
- 9 Pressure tap

Technical data

Nominal diffuser sizes	160, 200, 250, 315
Minimum volume flow rate, with $\Delta t_z = -8K$	9l/s - 32l/s or 32m ³ /h - 307m ³ /h
Maximum volume flow rate with $L_{WA} \approx 50dB(A)$	64l/s - 195l/s or 230m ³ /h - 702m ³ /h

Usage instructions

Please note that the minimum volume flows are not valid for free hanging or exposed installation. For these types of installation the minimum recommended flow rate is equivalent to an effective discharge velocity of 3.5m/s

Quick sizing

Quick sizing tables provide a good overview of the volume flow rates and corresponding sound power levels and differential pressures. The minimum volume flow rates apply to a supply air to room air temperature difference of -6 K. The maximum volume flow rates apply to a sound power level of approx. 50 dB (A) with damper blade position 0°.

RFD-V... (supply air), sound power level and total differential pressure.

Nominal size	q_v [l/s]	q_v [m ³ /h]	Ø Spigot	Damper blade position					
				0°		45°		90°	
				Δp_t [Pa]	L_{WA} [dB(A)]	Δp_t [Pa]	L_{WA} [dB(A)]	Δp_t [Pa]	L_{WA} [dB(A)]
160	20	72	158	6	17	7	16	10	17
160	33	118.8	158	15	31	19	31	27	31
160	47	169.2	158	31	41	38	41	56	41
160	60	216	158	51	48	61	48	91	48
200	30	108	198	5	17	7	17	9	17
200	50	180	198	14	32	18	32	26	32
200	70	252	198	28	42	36	42	51	42
200	90	324	198	46	50	60	50	85	50
250	50	180	248	5	20	7	20	10	20
250	80	288	248	14	34	19	34	26	34
250	110	396	248	26	43	36	43	50	43
250	140	504	248	41	50	58	51	81	50
315	70	252	313	5	20	6	20	9	19
315	110	396	313	12	34	16	33	23	33
315	150	540	313	23	43	30	43	42	42
315	190	684	313	36	50	48	50	67	49

Specification text

This specification text describes the general properties of the product. Texts for variants can be generated with our Easy Product Finder design programme.

Specification text

Swirl diffusers with circular diffuser face. Supply and extract air variants for comfort zones and industrial zones. Diffuser face with fixed control blades and variable internal geometry controlled via thermal actuator. In cooling supply air will discharge in a horizontal swirling pattern creating high induction levels. In heating supply air will switch to vertical discharge to penetrate into the occupied zone. For installation into all types of suspended ceilings and rooms without suspended ceilings. Ready-to-install component which consists of the diffuser face with radially arranged fixed air control blades and a plenum box with side entry, and suspension holes or suspension lugs. The diffuser face is fixed to the cross bar with a central screw. Thermal Actuator temperature range 18 °C to 32 °C. Spigot suitable for ducts to EN 1506 or EN 13180. Sound power level of the air-regenerated noise measured according to EN ISO 5135.

Note: Cooling supply air temperature of <22°C required to reset the thermal actuator

Note: Vertical heating requires supply air temperature of >28°C

Parts and characteristics

- Circular diffuser face
- Diffuser with radially arranged fixed air control blades
- Simple installation of the diffuser due to central rivnut

- Damper blade for volume flow rate balancing

Materials and surfaces

- Diffuser face made of galvanised steel
- Discharge nozzle made of aluminium
- Plenum box, non-visible adjustment mechanism and cross bar made of galvanised sheet steel
- P2: Powder-coated RAL 9006: 30 %
- P3: Powder-coated RAL 9010: 20 %
- P4: Powder-coated RAL 9005: 20 %
- P6: Powder-coated RAL CLASSIC colour 30 % gloss

Technical data

- Nominal diffuser sizes: 160, 200, 250, 315
- Minimum volume flow rate, with $\Delta t_z = -8K$: 9l/s – 32l/s or 32m³/h – 307m³/h
- Maximum volume flow rate with LWA $\approx 50dB(A)$: 64l/s – 195l/s or 230m³/h – 702m³/h

Usage instructions

- Please note that the minimum volume flows are not valid for free hanging or exposed installation. For these types of installation, the recommended minimum flow rate is equivalent to an effective discharge velocity of 3.5m/s

Order code

RFD-V – Z – DX – D12 – M – L – ADE / 200 × 198 / SB / P3 – P6 - RAL 9016
 1 2 3 4 5 6 7 8 9 10 11 12

1 Type

RFD-V Swirl diffuser

2 System

Z Supply air
 A Extract air

3 Construction

DX Standard

4 Inner lining (insulation)

No entry: without lining
 D06 inner lining 6 mm thick
 D12 inner lining 12 mm thick

5 Spigot damper for flow rate balancing

M with damper screen

6 Lip seal

No entry: without lip seal
 L with lip seal

7 Air distribution element

No entry: without air distribution element
 ADE with air distribution element

8 Nominal size [mm]

160, 200, 250, 315

9 Spigot diameter [mm]

158 (only for nominal size 160)
 198 (only for nominal size 200, 250)
 248 (only for nominal size 200, 250, 315)
 313 (only for nominal size 315)

10 Plenum box fixing

No entry: central threaded rod
 SB Fixing bracket

11 Exposed surface of diffuser face

P2 powder-coated RAL 9006 (white aluminium)
 P3 powder-coated, RAL 9010 (pure white)
 P4 powder-coated, RAL 9005 (deep black)
 P6 powder-coated, specify RAL CLASSIC colour

12 Surface plenum box

No entry: without surface finish
 P2 powder-coated RAL 9006 (white aluminium)
 P3 powder-coated, RAL 9010 (pure white)
 P4 powder-coated, RAL 9005 (deep black)
 P6 powder-coated, specify RAL CLASSIC colour

Gloss level
 RAL 9006 GU 30
 RAL 9010 and RAL 9005 GU 20
 All other RAL colours GU 30

Order example: RFD-V-Z-DX-D12-M-L/200×198/SB/P3-P6-RAL9016

Type	RFD-V – swirl diffuser
System	supply air
Construction	standard
Inner lining (insulation)	inner lining 12 mm thick
Spigot damper for volume flow rate balancing	with spigot damper
Lip seal	with lip seal
Air distribution element	with air distribution element
Nominal size [mm]	200
Spigot diameter [mm]	198
Plenum box fixing	fixing brackets
Exposed surface of diffuser face	powder-coated, RAL 9010 (pure white)
Surface plenum box	powder-coated, RAL 9016 (traffic white)

Dimensions

Circular diffuser face with plenum box for horizontal duct connection

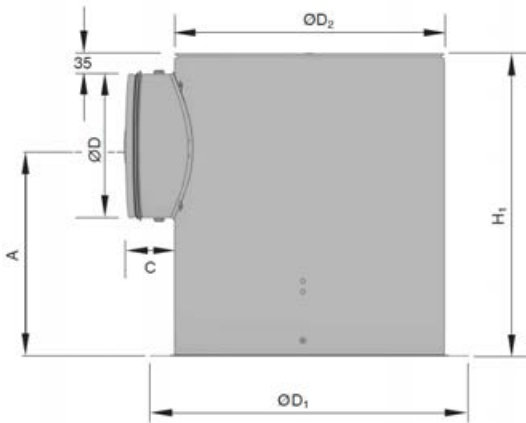

RFD-V...

Nominal size [mm]	ØD [mm]	H ₁ [mm]	A [mm]	ØD ₁ [mm]	ØD ₂ [mm]	C [mm]	Weight [kg]
160	158	346	232	350	269	76	4.1
200	198	451	317	400	316	76	6.0
200	248	451	292	400	316	76	6.3
250	198	451	317	450	367	76	7.2
250	248	451	292	450	367	76	7.4
315	248	521	362	550	466	76	10.5
315	313	521	330	550	466	76	10.7

Product details

Freely suspended installation of RFD-V

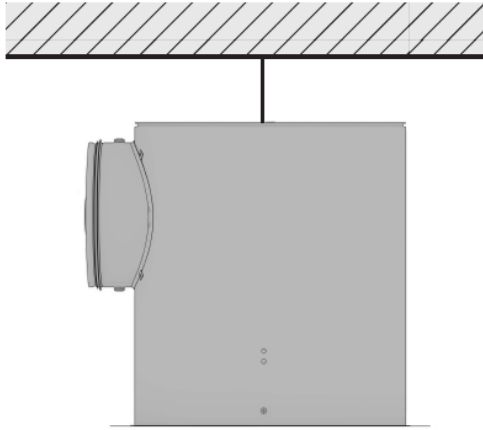

Freely suspended installation of RFD-V with SB fixing

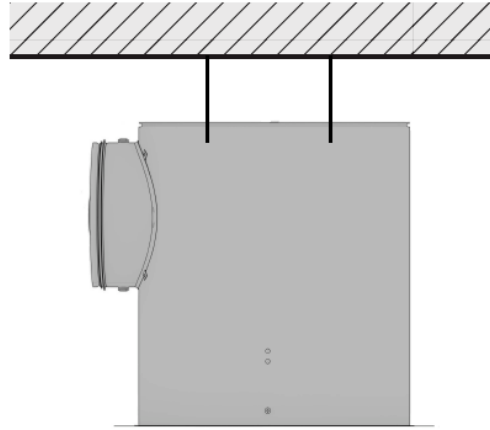

Three plenum support brackets provided on plenum body

M8 Captive nut provided in top of plenum

Flush ceiling installation of RFD-V

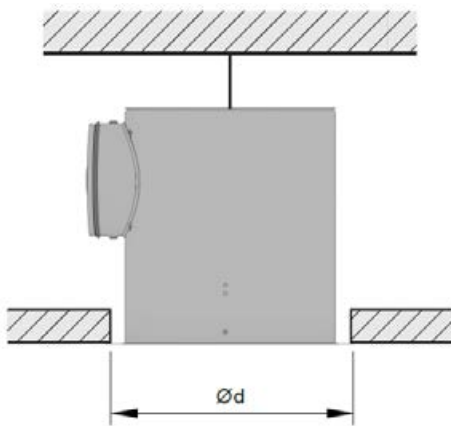

These are only schematic diagrams to illustrate installation details

RFD-V NS	160	200	250	315
Ceiling cutout Ød [mm]	299	346	397	551

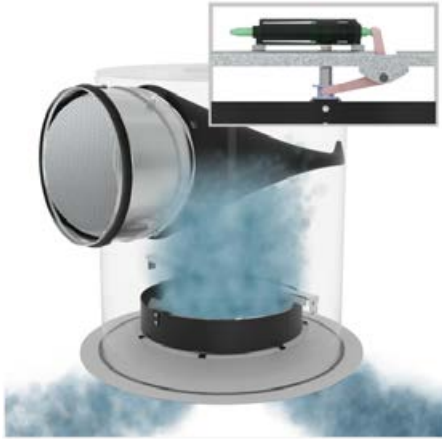
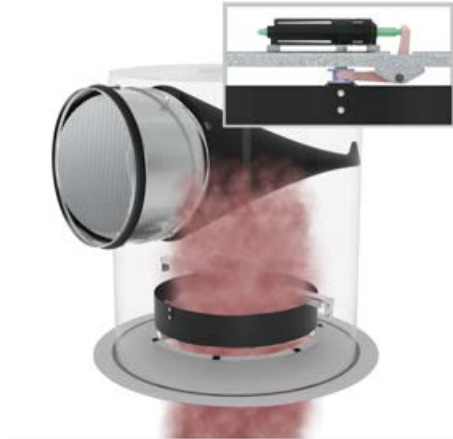
Horizontal radial air discharge in cooling**Vertical air discharge in heating****Thermal actuator function**

The RFD-V switches between horizontal and vertical discharge depending on supply air temperature, via a thermal actuator. When the supply air temperature rises above 28°C, the diffuser will enter heating mode and discharge vertically. When the supply air temperature falls below 22°C, the diffuser will switch back into cooling mode and discharge horizontally.

Volume flow rate balancing

When several diffusers are connected to just one volume flow controller, it may be necessary to balance the volume flow rates. Ceiling diffusers with plenum box and damper blade

The diffuser face can be removed to access the damper blade

The damper blade can then be set to any position between 0 and 90°, the damper blade can also be adjusted externally using the cam on the spigot.

Volume flow rate measurement

Ceiling diffusers with horizontal plenum box, damper blade and pressure diaphragm allow for volume flow rate balancing with the diffuser face in place.

Connect the pressure tap to the digital manometer

Read the effective pressure

Read the volume flow rate off the characteristic or calculate it

If necessary, adjust the damper blade position

Volume flow calculations

$$\textcircled{1} \quad q_v = C \times \sqrt{\Delta p_w}$$

$$\textcircled{2} \quad q_v = C \times \sqrt{\Delta p_w} \times \sqrt{\frac{1.2}{\rho}}$$

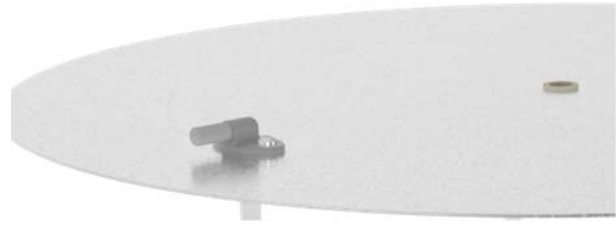

Please contact TROX UK for the required 'C' factors

Pressure tap on lid of plenum box

Nomenclature

$\varnothing D$ [mm]

Outer diameter of the spigot

$\varnothing D_1$ [mm]

Outer diameter of a circular diffuser face

$\varnothing D_2$ [mm]

Diameter of a circular plenum box

$\varnothing d$ [mm]

Ceiling cutout diameter

H, [mm]

Height of a plenum box

A [mm]

Position of the spigot, defined by the distance of the spigot centre line to the lower edge of the diffuser face

C [mm]

Length of the spigot

L_{WA} [dB(A)]

A-weighted sound power level of air-regenerated noise

q_v [m³/h]; [l/s]

Volume flow rate

Δt_z [K]

Supply air to room air temperature difference, i.e. supply air temperature minus room temperature

Δp_t [Pa]

Total differential pressure