

Ceiling swirl diffusers

Type VD

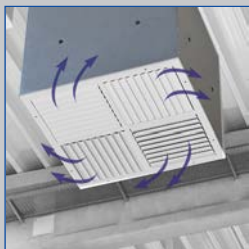

Horizontal swirling air discharge



Vertical air discharge



Protective cage



Extended border

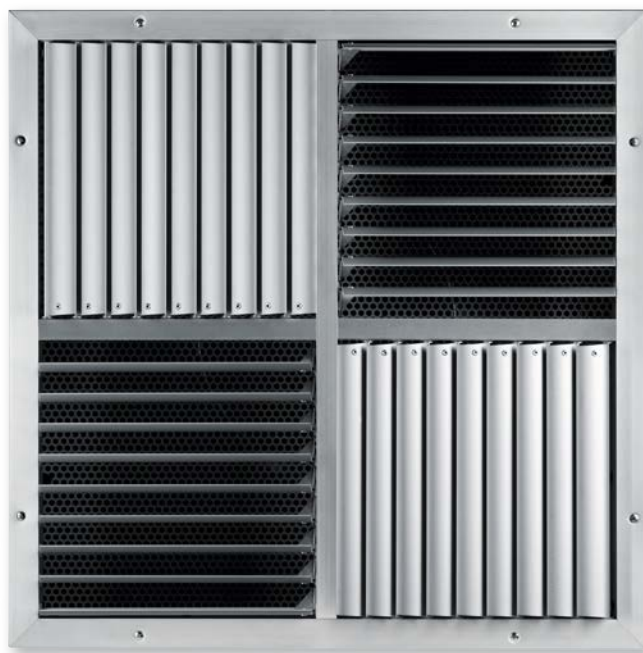

For high rooms, with adjustable air control blades

Square ceiling swirl diffusers, with manual or motorised adjustment of the air pattern to ensure draught-free ventilation of the occupied zone both in heating and cooling modes

- Nominal sizes 425, 600, 775, 1050
- Volume flow rate range 95 – 1490 l/s or 342 – 5364 m³/h
- Diffuser face made of aluminium with anodised finish
- For supply air
- For variable and constant volume flows
- High induction results in a rapid reduction of the temperature difference and airflow velocity
- Discharge direction can be adjusted manually or with an actuator
- Ideal for high rooms

Optional equipment and accessories

- Exposed diffuser face available in RAL CLASSIC colours
- Horizontal or vertical duct connection
- An extended border improves the horizontal air discharge in cooling mode
- Protective cage for use in gymnasiums
- Actuators for adjusting the air discharge direction

Type		Page		Page
VD	General information	VD – 2	Accessories	VD – 10
	Function	VD – 3	Dimensions and weight	VD – 12
	Technical data	VD – 5	Product details	VD – 13
	Quick sizing	VD – 6	Installation examples	VD – 14
	Specification text	VD – 7	Installation details	VD – 15
	Order code	VD – 8	Basic information and nomenclature	VD – 17
	Variants	VD – 9		

Application

Application

- Type VD ceiling swirl diffusers are used as supply air diffusers for high rooms in comfort and industrial zones
- For production halls, gymnasiums, theatres and conference rooms as well as for large internal spaces in airports, railway stations and shopping centres
- For mixed flow ventilation with different air patterns in heating and cooling modes
- Horizontal swirling supply air discharge in cooling mode
- The efficient swirl creates high induction levels, thereby rapidly reducing the temperature difference and airflow velocity
- Angled or vertical air discharge in heating mode

- For variable and constant volume flows
- For supply air to room air temperature differences from –12 to +15 K
- For room heights exceeding 3.8 m
- With freely suspended installation, an extended border supports the horizontal air discharge in cooling mode

Special characteristics

- With adjustable air control blades for high rooms
- The air pattern can be adjusted manually or with an actuator
- Horizontal or vertical duct connection

Nominal sizes

- 425, 600, 775, 1050

Description

Variants

- Diffuser face only

Connection

- H: Horizontal duct connection
- V: Vertical duct connection

Parts and characteristics

- Square diffuser face with four sections of blades
- Diffuser face with blades that can be adjusted simultaneously, for air discharge from horizontal (0°) to vertical (90°)
- Plenum box for horizontal or vertical duct connection

Accessories

- Electric actuators for adjusting the air discharge direction
- Extended border and protective cage

Useful additions

- TDC temperature difference control module

Construction features

- Spigot suitable for circular ducts to EN 1506 or EN 13180

Materials and surfaces

- Diffuser face made of extruded aluminium sections
- Plenum box, cross bar and extended border made of galvanised sheet steel
- Protective cage made of steel mesh

- Diffuser face with anodised finish, E6-C-0, natural colour
- Protective cage powder-coated RAL 9010, pure white
- Extended border powder-coated RAL 9006, white aluminium
- P1: Powder-coated, RAL CLASSIC colour

Standards and guidelines

- Sound power level of the air-regenerated noise measured according to EN ISO 5135

Maintenance

- Maintenance-free as construction and materials are not subject to wear
- Inspection and cleaning to VDI 6022

Disclosure of Chemicals

- RoHS EU Directive 2011/65/EU (RoHS)
 - This product or single variants comply with EU Directive 2011/65/EU (RoHS) on the restriction of the use of certain hazardous substances in electrical and electronic equipment. For more information, please refer to our Environmental Product Declarations.
- REACH 1907/2006 (EC Regulation REACH)
 - This product or single variants comply with the provisions of EC Regulation No. 1907/2006, also known as REACH (Registration, Evaluation, Authorisation and Restriction of Chemicals). For more information, please refer to our Environmental Product Declarations.

Functional description

Ceiling swirl diffusers in air conditioning systems create a swirl to supply air to rooms. The resulting airflow induces high levels of room air, thereby rapidly reducing the airflow velocity and the temperature difference between supply air and room air. Ceiling swirl diffusers allow for large volume flow rates. The result is a mixed flow ventilation in comfort zones, with good overall room ventilation, creating only very little turbulence in the occupied zone.

Type VD ceiling swirl diffusers have adjustable air control blades. Different air patterns allow for cooling or heating mode, or for the adjustment to varying loads. Horizontal air discharge is omnidirectional. Vertical air discharge is possible in heating mode. The supply air to room air temperature difference may range from -12 to +15 K.

An actuator (optional) adjusts the blades based on demand.

Schematic illustration of the VD, with plenum box for horizontal duct connection

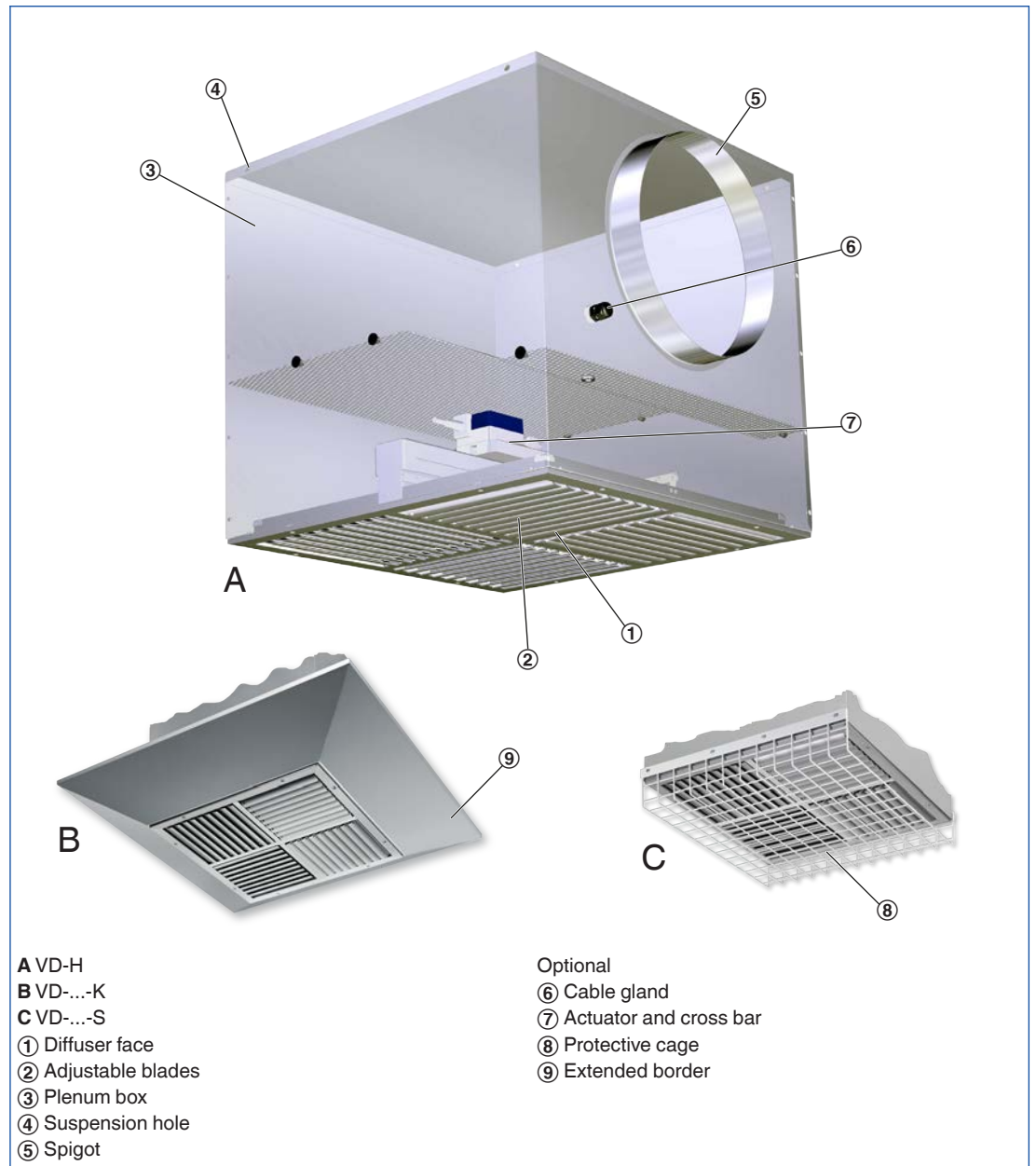

Air patterns

Horizontal omni directional air discharge



Vertical air discharge



Nominal sizes	425, 600, 775, 1050 mm
Minimum volume flow rate	95 – 675 l/s or 342 – 2430 m ³ /h
Maximum volume flow rate, with $L_{WA} \cong 50$ dB(A)	280 – 1490 l/s or 1008 – 5364 m ³ /h
Supply air to room air temperature difference	-12 to +15 K

Quick sizing tables provide a good overview of the volume flow rates and corresponding sound power levels and differential pressures.

The maximum volume flow rates apply to a sound power level of approx. 50 dB (A) with damper blade position 0°.

Exact values for all parameters can be determined with our Easy Product Finder design programme.

VD-H, sound power level and total differential pressure

Nominal size	\dot{V}		Δp_t Pa	L_{WA} dB(A)
	l/s	m ³ /h		
425	95	342	6	21
	150	540	15	32
	215	774	31	42
	280	1008	52	50
600	210	756	9	28
	310	1116	20	37
	410	1476	35	44
	510	1836	54	50
775	375	1350	8	26
	510	1836	14	34
	660	2376	23	41
	885	3186	42	50
1050	675	2430	13	36
	825	2970	19	41
	975	3510	27	46
	1120	4032	35	50

VD-V, sound power level and total differential pressure

Nominal size	\dot{V}		Δp_t Pa	L_{WA} dB(A)
	l/s	m ³ /h		
425	95	342	6	17
	175	630	19	31
	260	936	41	41
	340	1224	70	50
600	210	756	7	19
	355	1278	21	32
	410	1476	28	36
	660	2376	75	50
775	375	1350	6	22
	545	1962	14	32
	715	2574	24	42
	885	3186	38	50
1050	675	2430	11	30
	950	3420	22	38
	1225	4410	37	44
	1490	5364	55	50

This specification text describes the general properties of the product. Texts for variants can be generated with our Easy Product Finder design programme.

Ceiling swirl diffusers with square diffuser face for high rooms in comfort and industrial zones. For supply air only. Blades in diagonally opposed sections can be adjusted for air discharge from horizontal (0°) to vertical (90°). Horizontal air discharge with high induction. For freely suspended installation or for suspended ceilings of all types.

Ready-to-install component which consists of the diffuser face with four equal blade arrays, a cross bar for fixing the actuator, a plenum box with side entry or top entry spigot, and suspension holes. The diffuser face is fixed to the plenum box with a screw.

Spigot suitable for ducts to EN 1506 or EN 13180. Sound power level of the air-regenerated noise measured according to EN ISO 5135.

Special characteristics

- With adjustable air control blades for high rooms
- The air pattern can be adjusted manually or with an actuator
- Horizontal or vertical duct connection

Materials and surfaces

- Diffuser face made of extruded aluminium sections
- Plenum box, cross bar and extended border

- made of galvanised sheet steel
- Protective cage made of steel mesh
- Diffuser face with anodised finish, E6-C-0, natural colour
- Protective cage powder-coated RAL 9010, pure white
- Extended border powder-coated RAL 9006, white aluminium
- P1: Powder-coated, RAL CLASSIC colour

Technical data

- Nominal sizes: 425, 600, 775, 1050 mm
- Minimum volume flow rate: 95 – 675 l/s or 342 – 2430 m³/h
- Maximum volume flow rate, with $L_{WA} \cong 50$ dB(A): 280 – 1490 l/s or 1008 – 5364 m³/h
- Supply air to room air temperature difference: -12 to +15 K

Sizing data

- \dot{V} _____
[m³/h]
- Δp_t _____
[Pa]
- Air-regenerated noise
- L_{WA} _____
[dB(A)]

VD

VD – V – E1 – K / 600 / P1 – RAL ...					
↓	↓	↓	↓	↓	↓
1	2	3	4	5	6

1 Type

VD Swirl diffuser

2 Connection

No entry: diffuser face only

H Horizontal, with plenum box

V Vertical, with plenum box

3 Adjustment

No entry: manual

Electric actuator

E1 230 V AC, 3-point

E2 24 V AC/DC, 3-point

E3 24 V AC/DC, modulating 2 – 10 V DC

4 Accessories

Only for connections H and V
supplied separately

K Extended border

S Protective cage

K and S cannot be combined

Order example: VD-V-E1-K/600/P1-RAL 9016

Connection	Vertical
Adjustment	Electric actuator 230 V AC
Attachment	Extended border
Nominal size	600 mm
Exposed surface of diffuser face	RAL 9016, traffic white, gloss level 70 %

5 Nominal size [mm]

425

600

775

1050

6 Exposed surface of diffuser face

No entry: anodised, natural colour,
E6-C-0

P1 Powder-coated, specify RAL CLASSIC
colour

Gloss level

RAL 9010 50 %

RAL 9006 30 %

All other RAL colours 70 %

VD-H

Variant

- Ceiling swirl diffuser with square diffuser face
- With plenum box for horizontal duct connection

Nominal sizes

- 425, 600, 775, 1050

Parts and characteristics

- Square diffuser face with four sections of

blades

- Diffuser face with blades that can be adjusted simultaneously, for air discharge from horizontal (0°) to vertical (90°)
- Plenum box for horizontal duct connection

Construction features

- Spigot suitable for circular ducts to EN 1506 or EN 13180

VD-V

Variant

- Ceiling swirl diffuser with square diffuser face
- With plenum box for vertical duct connection

Nominal sizes

- 425, 600, 775, 1050

Parts and characteristics

- Square diffuser face with four sections of

blades

- Diffuser face with blades that can be adjusted simultaneously, for air discharge from horizontal (0°) to vertical (90°)
- Plenum box for vertical duct connection

Construction features

- Spigot suitable for circular ducts to EN 1506 or EN 13180
-

VD-V-K



VD-* -K

Accessories

- Extended border

Nominal sizes

VD-* -K

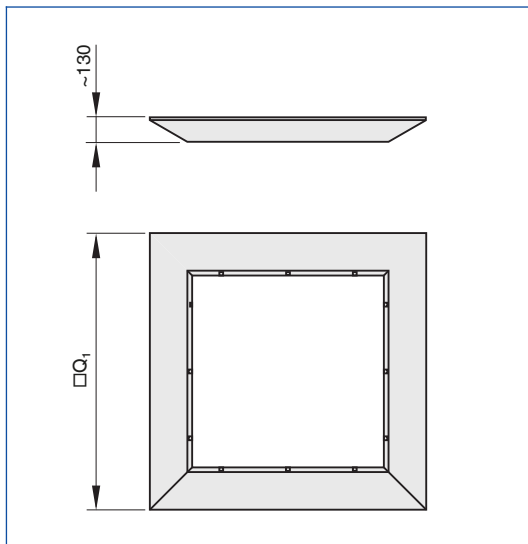

- 425, 600, 775, 1050

Parts and characteristics

- An extended border supports the horizontal air discharge in cooling mode

VD-* -K

Nominal size	□Q ₁	m	
	mm		kg
425	833		5
600	1003		6
775	1171		8
1050	1451		10

VD-V-S



VD-*-S

Accessories

- Protective cage

Nominal sizes

VD-*-S

- 425, 600, 775, 1050

Parts and characteristics

- A protective cage protects the blades, e.g. in gymnasiums

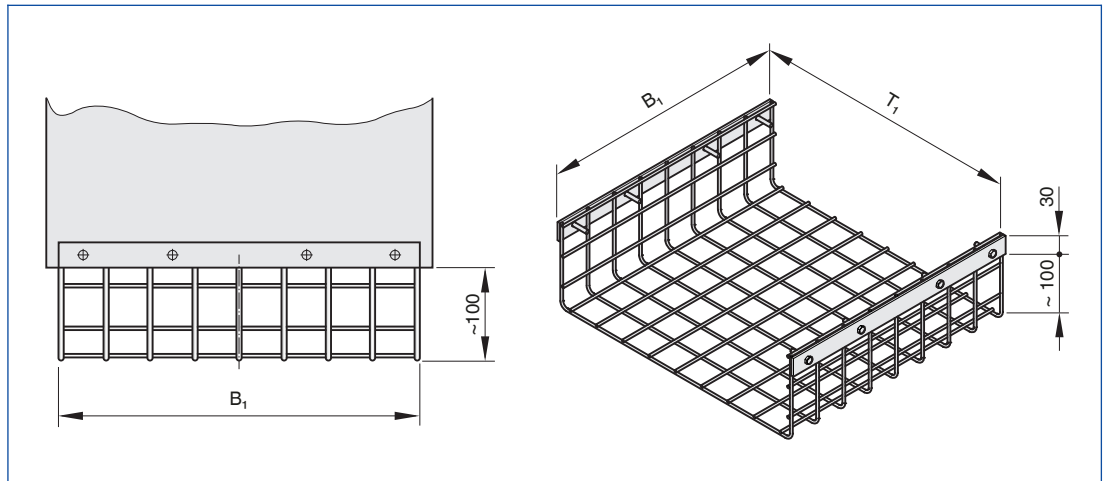

VD-*-S

Nominal size	B ₁	T ₁	m
	mm	mm	kg
425	404	449	3
600	604	624	4
775	754	799	6
1050	1054	1074	9

VD-H

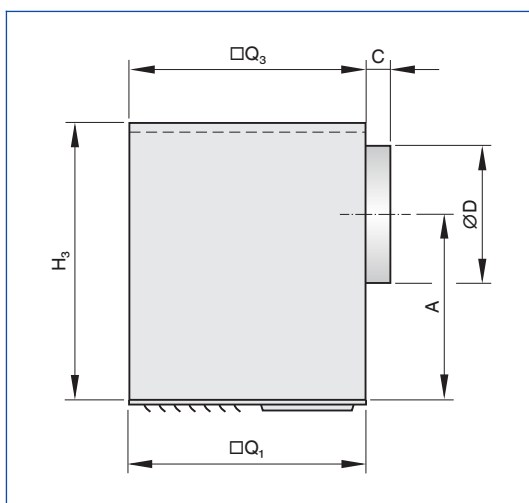

VD-H

Nominal size	□Q ₁	□Q ₃	H ₃	ØD	A	C	m
	mm	mm	mm	mm	mm	mm	kg
425	425	425	500	248	335	46	11
600	595	600	550	313	353	48	19
775	763	775	750	448	498	60	34
1050	1043	1050	800	498	523	60	57

Weights apply to the variant with actuator

VD-V

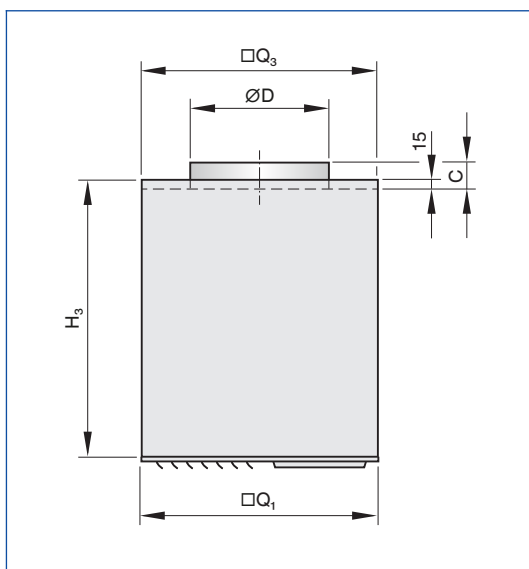

VD-V

Nominal size	□Q ₁	□Q ₃	H ₃	ØD	C	m
	mm	mm	mm	mm	mm	kg
425	425	425	500	248	46	11
600	595	600	550	313	48	19
775	763	775	550	448	60	29
1050	1043	1050	600	498	60	51

Weights apply to the variant with actuator

Diffuser face VD

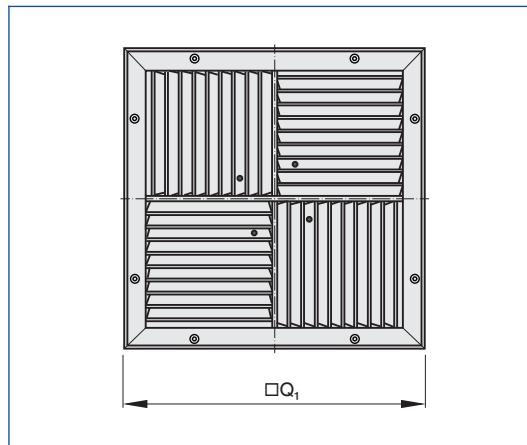

VD

Nominal size	$\square Q_1$	A_{eff}	A_{eff} vertical air discharge
	mm	m ²	m ²
425	425	0.0307	0.0781
600	595	0.0685	0.1819
775	763	0.1242	0.3405
1050	1043	0.2247	0.6358

Freely suspended installation



Installation and commissioning

- Preferably for rooms with a clear height from 3.8 m
- Flush ceiling installation
- VD-...-K: Also freely suspended installation
- VD-V: Ceiling distance of at least 300 mm allows for continuous adjustment of the air pattern
- Horizontal or vertical duct connection

Installation information

- Installation can be flush with the ceiling or freely suspended
- If the VD is mounted flush with an open cell ceiling, the resulting air pattern is the same as with freely suspended installation
- Continuous adjustment of the air pattern using an actuator is only possible with freely suspended installation, installation flush with an open cell ceiling, or installation with the diffuser protruding from an open cell ceiling
- Installation and making connections to be performed by others

These are only schematic diagrams to illustrate installation details.

Flush ceiling installation

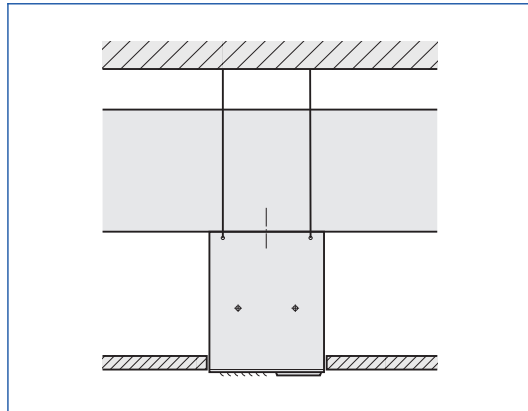

- Two discharge directions, horizontal and vertical
- Horizontal or vertical duct connection

Protruding installation

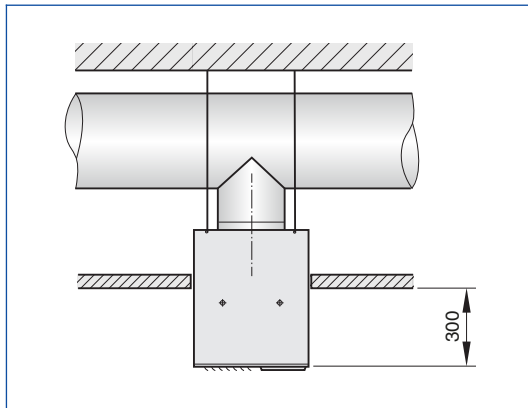

- Continuous adjustment of the discharge direction
- Vertical duct connection
- 300 mm minimum distance to the suspended ceiling

Freely suspended installation

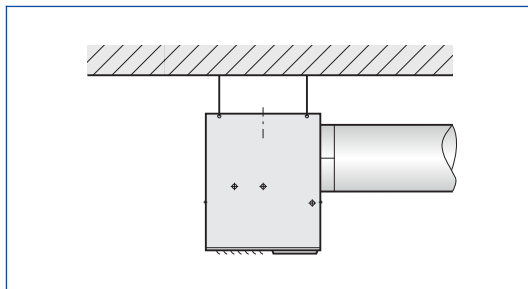

- Continuous adjustment of the discharge direction
- Horizontal or vertical duct connection
- Preferably for industrial zones

Freely suspended installation of VD-...-K

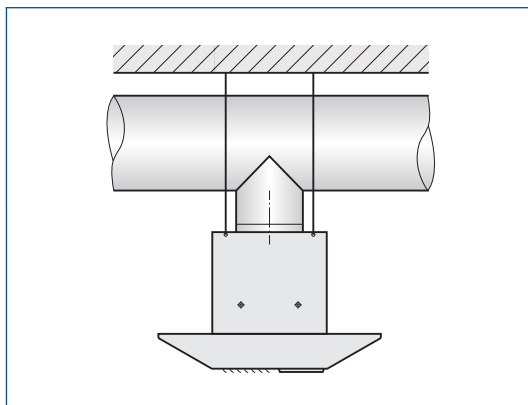

- Two discharge directions, horizontal and vertical
- An extended border supports the horizontal air discharge
- Horizontal or vertical duct connection
- Preferably for comfort zones

Principal dimensions

$\varnothing D$ [mm]

Outer diameter of the spigot

$\varnothing D_1$ [mm]

Outer diameter of a circular diffuser face

$\varnothing D_2$ [mm]

Diameter of a circular diffuser face style

$\varnothing D_3$ [mm]

Diameter of a circular plenum box

$\square Q_1$ [mm]

Outer diameter of a square diffuser face

$\square Q_2$ [mm]

Dimensions of a square diffuser face style

$\square Q_3$ [mm]

Dimensions of a square plenum box

H_1 [mm]

Distance (height) from the lower edge of the

suspended ceiling to the lower edge of the diffuser face

H_2 [mm]

Height of a ceiling diffuser, from the lower edge of the suspended ceiling to the upper edge of the spigot

H_3 [mm]

Height of a ceiling diffuser with plenum box, from the lower edge of the suspended ceiling to the upper edge of the plenum box or of the spigot

A [mm]

Position of the spigot, defined by the distance of the spigot centre line to the lower edge of the suspended ceiling

C [mm]

Length of the spigot

m [kg]

Weight

Nomenclature

L_{WA} [dB(A)]

A-weighted sound power level of air-regenerated noise

\dot{V} [m^3/h] and [l/s]

Volume flow rate

Δt_z [K]

Supply air to room air temperature difference, i.e.

supply air temperature minus room temperature

Δp_t [Pa]

Total differential pressure

A_{eff} [m^2]

Effective air discharge area

All sound power levels are based on 1 pW.