

Disc valves

Z-LVS



For supply air

Circular disc valves with manually adjustable annular gap

- Nominal sizes 100, 125, 160, 200 mm
- Volume flow rate range 10 – 90 l/s or 36 – 324 m³/h
- Diffuser face made of formed sheet steel, powder-coated
- For variable and constant volume flows
- For ceiling and wall installation
- Easy to install
- Volume flow rate balancing by simply turning the valve disc
- Inexpensive solution for small rooms

General information	2	Order code	6
Function	3	Dimensions	7
Technical data	4	Product details	8
Quick sizing	4	Nomenclature	9
Specification text	5		

General information

Application

- Disc valves are used as supply air devices in small rooms
- Horizontal radial supply air discharge
- For variable and constant volume flows
- For room heights up to 4 m (lower edge of suspended ceiling)
- For walls and suspended ceilings

Special characteristics

- Continuous volume flow rate balancing by turning the valve disc
- Easy to install

Nominal sizes

- 100, 125, 160, 200

Parts and characteristics

- Valve disc with threaded spindle and lock nut
- Valve casing including cross bar with orifice for the threaded spindle
- Installation subframe that accommodates the disc valve

Material and surfaces

- Valve casing and valve disc made of sheet steel
- Installation subframe, threaded spindle and lock nut made of galvanised steel
- Foam seal
- Valve casing and valve disc powder-coated, similar to RAL 9010

Standards and guidelines

- Sound power level of the air-regenerated noise measured according to EN ISO 5135

Maintenance

- Low maintenance as construction and materials are not subject to wear
- Inspection and cleaning to VDI 6022

Disclosure of Chemicals

- RoHS EU Directive 2011/65/EU (RoHS)
 - This product or single variants comply with EU Directive 2011/65/EU (RoHS) on the restriction of the use of certain hazardous substances in electrical and electronic equipment. For more information, please refer to our Environmental Product Declarations
- REACH 1907/2006 (EC Regulation REACH)
 - This product or single variants comply with the provisions of EC Regulation No. 1907/2006, also known as REACH (Registration, Evaluation, Authorisation and Restriction of Chemicals). For more information, please refer to our Environmental Product Declarations

Function

Supply air valves direct the air from air conditioning systems into the room. The resulting airflow induces high levels of room air, thereby rapidly reducing the airflow velocity and the temperature difference between supply air and room air. The result is a mixed flow ventilation in comfort zones, with good overall room

ventilation, creating only very little turbulence in the occupied zone. Type Z-LVS disc valves have a valve disc that can be turned. Horizontal air discharge is radial. This valve disc facilitates volume flow rate balancing for commissioning.

Schematic illustration

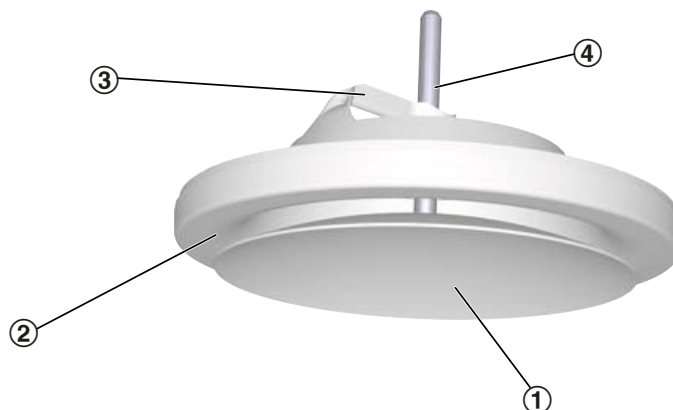

- ① Valve disc
- ② Valve casing
- ③ Cross bar
- ④ Threaded spindle with lock nut

Horizontal air discharge

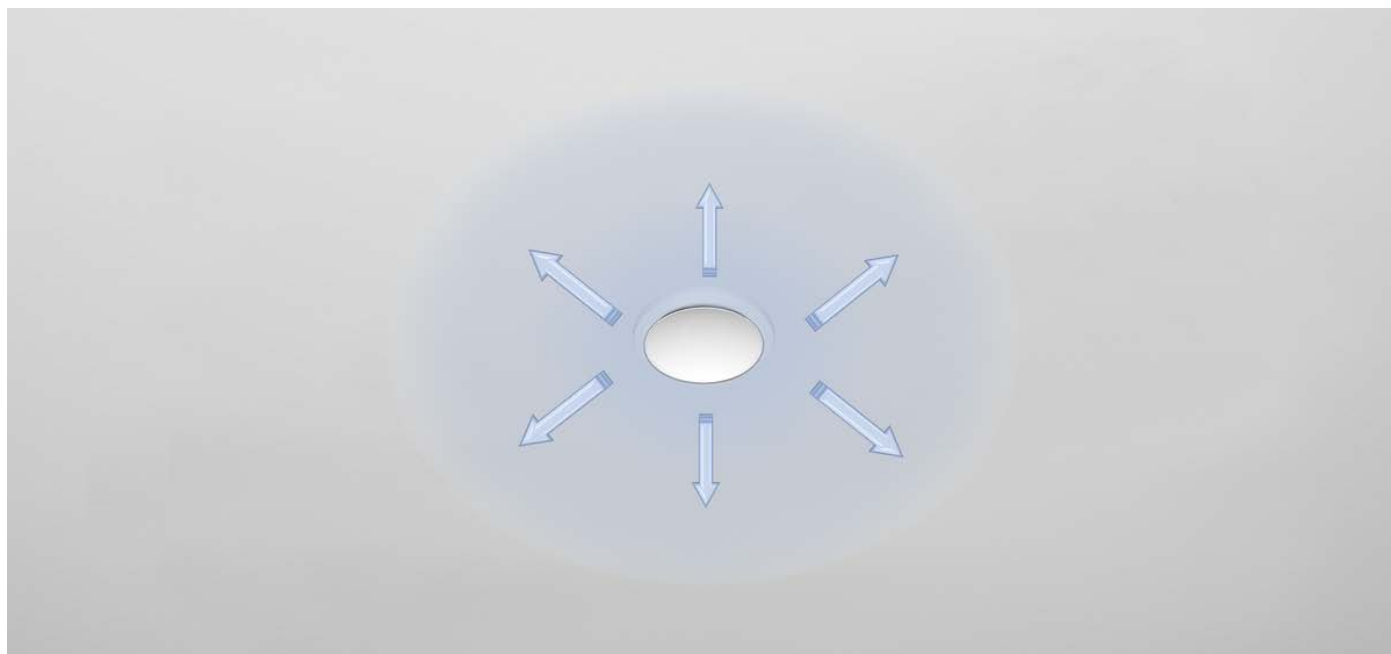

Technical data

Nominal sizes	100, 125, 160, 200 mm
Minimum volume flow rate	10 – 30 l/s from 36 – 108 m ³ /h
Maximum volume flow rate	25 – 90 l/s from 90 – 324 m ³ /h

Quick sizing

Quick sizing tables provide a good overview of the volume flow rates and corresponding sound power levels and differential pressures.

Z-LVS/100, Z-LVS/125, sound power level and total differential pressure

NS			Airway width = 12 mm		Airway width = 10 mm		Airway width = 8 mm	
	Q _v [litres per second]	Q _v [m ³ /h]	Δp _t [Pa]	LWA [dB(A)]	Δp _t [Pa]	LWA [dB(A)]	Δp _t [Pa]	LWA [dB(A)]
100	10	36	9	<15	11	<15	14	<15
100	15	54	20	23	24	24	32	27
100	20	72	35	31	42	33	57	36
100	25	90	54	38	66	40	89	43
125	10	36	5	<15	7	<15	11	<15
125	15	54	10	<15	15	<15	24	17
125	20	72	18	17	27	21	43	26
125	25	90	28	23	43	28	67	33

Z-LVS/160, Z-LVS/200, sound power level and total differential pressure

NS			Airway width = 20 mm		Airway width = 15 mm		Airway width = 10 mm	
	Q _v [litres per second]	Q _v [m ³ /h]	Δp _t [Pa]	LWA [dB(A)]	Δp _t [Pa]	LWA [dB(A)]	Δp _t [Pa]	LWA [dB(A)]
160	20	72	4	<15	6	<15	13	19
160	30	108	8	<15	15	21	30	32
160	40	144	15	24	26	30	54	42
160	50	180	23	31	41	38	84	49
200	30	108	4	<15	8	<15	14	<15
200	50	180	12	<15	21	19	40	26
200	70	252	24	25	41	30	78	36
200	90	324	40	33	68	38	129	44

Sizing example

Given data

q_v = 20 l/s (72 m³/h)

Supply air valve

Maximum sound power level 32 dB(A)

Quick Sizing

Type Z-LVS

Selectable nominal sizes: 100, 125, 160

Selected: Z-LVS/125

Specification text

This specification text describes the general characteristics of the product. Texts for variants can be generated with our Easy Product Finder design program.

Specification text

Circular disc valves as supply air devices, preferably for small rooms. For installation into walls and suspended ceilings. Ready-to-install component which consists of a valve casing with cross bar, a valve disc with threaded spindle, and an installation subframe.

The valve disc can be turned for volume flow rate balancing. The valve setting can be fixed with a lock nut.

Spigot suitable for ducts to EN 1506 or EN 13180.

Sound power level of the air-regenerated noise measured according to EN ISO 5135.

Special characteristics

- Continuous volume flow rate balancing by turning the valve disc
- Easy to install

Material and surfaces

- Valve casing and valve disc made of sheet steel
- Installation subframe, threaded spindle and lock nut made of galvanised steel
- Foam seal
- Valve casing and valve disc powder-coated, similar to RAL 9010

Technical data

- Nominal sizes: 100, 125, 160, 200 mm
- Minimum volume flow rate: 10 – 30 l/s or 36 – 108 m³/h
- Maximum volume flow rate: 25 to 90 l/s or 90 to 324 m³/h

Sizing data

- Volume flow rate q_v [m³/h] (information required for sizing)

Order code

Z-LVS / 160

| |
1 2**1 Type**

Z-LVS Disc valve

2 Nominal size [mm]

100, 125, 160, 200

Order example: Z-LVS/160

Nominal size

160

Dimensions

Z-LVS

Installation subframe for LVS and Z-LVS

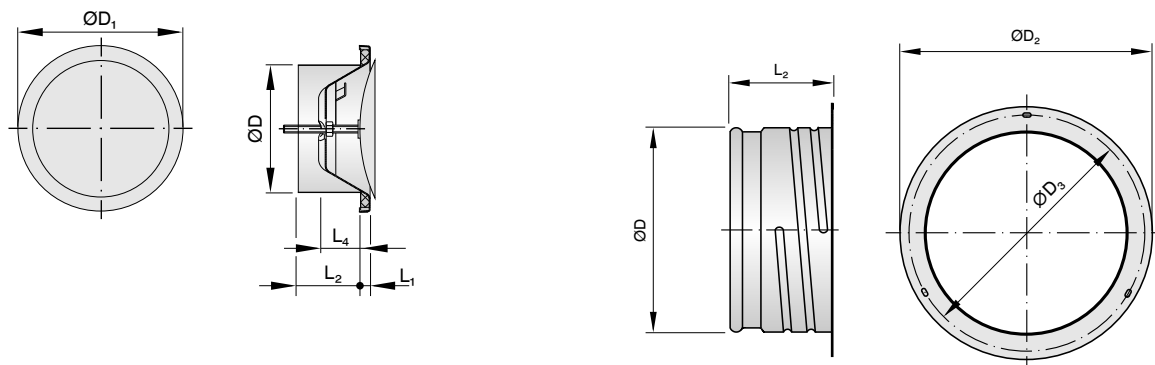

NS	ØD ₁	L ₁	L ₂	L ₄	ØD	ØD ₂	ØD ₃	M
	mm	mm	mm	mm	mm	mm	mm	kg
100	132	8	50	32	99	122	114	0.23
125	162	9	50	38	124	148	140	0.32
160	192	10	50	43	159	184	176	0.5
200	245	11	50	52	199	225	217	0.67

Product details

Installation and commissioning

- Installation flush with the wall or ceiling
- Perform volume flow rate balancing by turning the valve disc, then tighten the lock nut to fix the valve disc in the required position

These are only schematic diagrams to illustrate installation details.

Installation flush with the wall or ceiling, with installation subframe

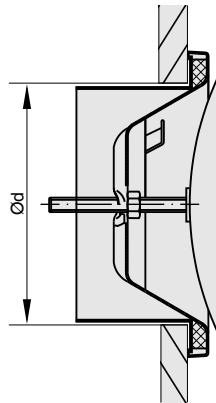

Installation opening

NS	$\varnothing d$ mm
100	104
125	129
160	164
200	204

Setting range

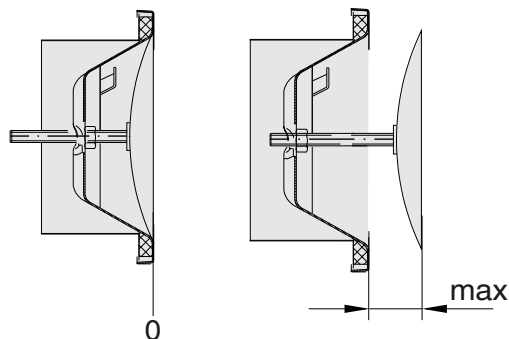

Nominal size 100: max = 12 mm

Nominal size 125: max = 15 mm

Nominal size 160, 200: max = 20 mm

Nomenclature

NS [mm]
Nominal size

ØD [mm]
Outer diameter of the spigot

ØD₁ [mm]
Outer diameter of a circular diffuser face

L₁ [mm]
Length of the face cover ring

L₂ [mm]
Installed length

m [kg]
Weight

L_{WA} [dB(A)]
A-weighted sound power level of air-regenerated noise

q_v [m³/h]; [l/s]
Volume flow rate

Δt_z [K]
Supply air to room air temperature difference, i.e. supply air temperature minus room temperature

Δp_t [Pa]
Total differential pressure

All sound power levels are based on 1 pW.