



Air handling unit

X-CUBE



TROX

TROX SE

Heinrich-Trox-Platz

47506 Neukirchen-Vluyn

Germany

Telephone: +49 (0) 2845 202-0

Fax: +49 (0) 2845 202-265

E-Mail: trox-de@troxgroup.com

Internet: www.troxtechnik.com

A00000044678, 12, GB/en

08/2025

© TROX SE 2016

About this manual

This transport and installation manual enables operating or service personnel to use the X-CUBE air handling unit (AHU) safely and efficiently.

The manual must be kept near the unit to be available for use at all times.

This transport and installation manual is intended for use by fitting and installation companies, operators, in-house technicians, technical staff or instructed persons, and skilled qualified electricians or air conditioning technicians.

It is essential that these individuals read and fully understand this manual before starting any work. The basic prerequisite for safe working is to comply with the safety notes and all instructions in this manual.

The local regulations for health and safety at work and the general safety regulations for the area of application of the air handling unit also apply.

Illustrations in this transport and installation manual are mainly for information and may differ from the actual design of the air handling unit.

Other applicable documentation

In addition to these instructions, the following documents apply:

- Order-specific approval drawing
- Order-specific air handling unit data sheet from TROX
- Data sheets for components from other suppliers, if any
- Circuit diagram for air handling unit with controls
- Additional drawings, if any
- X-CUBE operating manual

TROX contact information

To ensure that your request is processed as quickly as possible, please have the following information available:

- Product name
- TROX order number and line number
- Delivery date
- Brief description of fault or issue

Online	www.troxtechnik.com
Phone	+49 2845 202-0

Copyright

This document, including all illustrations, is protected by copyright and pertains only to the corresponding product.

Any use without our consent may be an infringement of copyright, and the violator will be held liable for any damage.

This applies in particular to:

- Publishing content
- Copying content
- Translating content
- Microcopying content
- Saving content to electronic systems and editing it

Limitation of liability

The information in this manual has been compiled with reference to the applicable standards and guidelines, the state of the art, and our expertise and experience of many years.

The manufacturer does not accept any liability for damages resulting from:

- Non-compliance with this manual
- Incorrect use
- Operation or handling by untrained individuals
- Unauthorised modifications
- Technical changes
- Use of non-approved replacement parts

The actual scope of delivery may differ from the information in this manual for bespoke constructions, additional order options or as a result of recent technical changes.

The obligations agreed in the order, the general terms and conditions, the manufacturer's terms of delivery, and the legal regulations in effect at the time the contract is signed shall apply.

We reserve the right to make technical changes.

Claims for material defects

Claims for material defects are subject to the seller's terms of delivery.

Safety notes

Symbols are used in this manual to alert readers to areas of potential hazard. Signal words express the degree of the hazard.

Comply with all safety instructions and proceed carefully to avoid accidents, injuries and damage to property.

DANGER!

Imminently hazardous situation which, if not avoided, will result in death or serious injury.

WARNING!

Potentially hazardous situation which, if not avoided, may result in death or serious injury.

CAUTION!

Potentially hazardous situation which, if not avoided, may result in minor or moderate injury.

NOTICE!

Potentially hazardous situation which, if not avoided, may result in property damage.

ENVIRONMENT!

Environmental pollution hazard.







Tips and recommendations



Useful tips and recommendations as well as information for efficient and fault-free operation.





Specific safety notes

The following symbols are used in safety notes to alert you to specific hazards:

Warning signs	Type of danger
	Warning - danger of crushing.
	Warning – hand injuries.
	Warning – high-voltage.
	Warning – danger of falling.
	Warning – suspended load.
	Warning – danger zone.

Additional markers

In order to highlight instructions, results, lists, references and other elements, the following markers are used in this manual:

Marker	Explanation
 1., 2., 3. ...	Step-by-step instructions
	Results of actions
	References to sections in this manual and to other applicable documents
	Lists without a defined sequence
[Switch]	Operating elements (e.g. push buttons, switches), display elements (e.g. LEDs)
'Display'	Screen elements (e.g. buttons or menus)

1	Overview	6	5.8	Connecting the AHU to the power supply	52
2	Safety	7	5.9	Integrating the air handling unit with the MCE	52
	2.1 System owner's responsibility	7	5.10	Connecting the measuring and control technology to the on-site PC or on-site network	53
	2.2 Personnel requirements	7			
	2.3 Personal protective equipment	8			
	2.4 Dangers when handling the AHU	8			
	2.5 Behaviour in the event of hazardous situations or accidents	10	6	Initial commissioning	54
3	Transport and storage	11	6.1	Safety notes regarding initial commissioning	54
	3.1 Delivery of the air handling unit	11	6.2	Before initial commissioning	54
	3.1.1 Delivery type	11	6.3	Setting up AHU casing units	55
	3.1.2 Symbols on the packaging	11	6.3.1	Inspection doors	55
	3.2 Delivery check	11	6.3.2	☉ Centrifugal fan	55
	3.3 Transporting packages	12	6.3.3	➡ Filter unit	58
	3.3.1 Safety notes regarding transport	12	6.3.4	☒ Heating coil/cooling coil	58
	3.3.2 Transporting packages with a forklift or pallet truck	13	6.3.5	Electric air heater	59
	3.3.3 Transporting packages with a crane	14	6.3.6	☒ Run-around coil system	59
	3.4 Storage and functional integrity	19	6.3.7	☒ Multileaf dampers	61
	3.4.1 Storage	19	6.3.8	☒ Sound attenuator	61
	3.4.2 Functional integrity of components	19	6.3.9	☒ Rotary heat exchanger	61
	3.5 Unpacking	20	6.3.10	☒ Plate heat exchanger	62
	3.5.1 Removing transport locks	20	6.3.11	☒ Humidifier	63
4	Setup and installation	22	6.3.12	Electrical system	63
	4.1 Safety instructions	22	6.4	Starting the air handling unit	63
	4.2 Requirements for the installation location	23	6.4.1	Before you start the AHU	63
	4.2.1 Requirements for indoor installation	23	6.4.2	Switching on	64
	4.2.2 Requirements for outdoor installation	23	7	Removal and disposal	65
	4.3 Preventing vibration and structure-borne noise	24	7.1	Safety notes regarding disassembly and disposal	65
	4.4 Setting up and assembling the AHU/ components	24	7.2	Disassembly	66
	4.4.1 Setting up the AHU/AHU casing units	25	7.3	Disposal	66
	4.4.2 Assembling AHU casing units	26	8	Glossary	68
	4.4.3 Installing the plate heat exchanger	30	9	Index	69
	4.4.4 Additional assembly steps for outdoor units	37			
	4.4.5 Installing accessories	40			
5	Installation	41			
	5.1 Safety notes regarding installation	41			
	5.2 Before installation	41			
	5.3 Sizing and connecting the condensate drain	42			
	5.4 ☒ Connecting the heating coil/cooling coil	45			
	5.5 ☒ Connecting the steam heat exchanger	46			
	5.6 ☒ Connecting the run-around coil system	47			
	5.7 Wiring	50			

1 Overview



Fig. 1: X-CUBE overview

An X-CUBE air handling unit is shipped either fully assembled or in parts, depending on its size. The following table lists the components, or casing units, that can make up an air handling unit. The components actually used for a particular air handling unit are listed in the order-specific technical data sheet.

AHU casing units

Symbol	Meaning	Symbol	Meaning
	Heating coil		Multileaf dampers
	Cooling coil		Humidifier
	Filter		Run around coil system
	Centrifugal fan		Hydraulic unit for run around coil system
	Rotary heat exchanger		Plate heat exchanger
	Sound attenuator		Controls
			Touch panel (MMI)

2 Safety

2.1 System owner's responsibility

System owner

The system owner is a natural or legal person who for commercial or business purposes owns or manages the air handling unit or allows third parties to use or operate it, but continues to bear legal responsibility for the safety of users, staff or third parties while the product is in use.

System owner's obligations

The unit is intended for commercial use. The system owner is therefore subject to the legal obligations of occupational health and safety regulations.

In addition to the safety notes in this manual, the applicable regulations for safety, accident prevention and environmental protection must also be complied with.

In particular:

- The system owner must establish on site a coherent fire protection strategy and include the air handling unit in this strategy.
- The system owner must establish on site a coherent lightning protection strategy and include the air handling unit in this strategy.
- The system owner must name responsible persons for transport, storage, assembly, installation, commissioning, transfer, disassembly and removal of the unit.
- The system owner must commission a skilled qualified electrician to create equipotential bonding.
- The system owner has to ensure that all individuals who handle or use the air handling unit have read and understood this manual.
- The system owner must provide the employees with the required personal protective equipment.
- The system owner must have all safeguards tested regularly to ensure that they are functional and complete.
- The system owner must ensure compliance with the national legal provisions.
- The system owner must have technical and hygiene tests carried out and documented before commissioning the air handling unit for the first time. The tests have to be repeated at regular intervals.

2.2 Personnel requirements



WARNING!

Danger of injury or risk of damage to property due to insufficiently qualified individuals!

Insufficiently qualified individuals are not aware of the risks involved in working with the air handling unit and are hence likely to put themselves or others into danger, causing severe or fatal injuries.

- Have any work carried out only by qualified personnel.
- Keep insufficiently qualified individuals away from the work area.

Crane driver

Crane drivers are physically and mentally able to operate a crane on their own.

Crane drivers are qualified to operate a crane and have proven the required skillset to the system owner.

Crane drivers are commissioned by the system owner to move units from the delivery truck to the installation location. Crane drivers are commissioned in writing if the crane is a mobile crane.

Crane drivers have to be at least 18 years old.

Forklift driver

Forklift drivers are qualified to operate driver-operated forklift trucks; they are commissioned in writing by the system owner to operate such a truck.

Forklift drivers are responsible for moving pallets.

HVAC technician

HVAC technicians are individuals who have sufficient professional or technical training in the field they are working in to enable them to carry out their assigned duties at the level of responsibility allocated to them and in compliance with the relevant guidelines, safety regulations and instructions. HVAC technicians are individuals who have in-depth knowledge and skills related to HVAC systems; they are also responsible for the professional completion of the work under consideration.

HVAC technicians are individuals who have sufficient professional or technical training, knowledge and actual experience to enable them to work on HVAC systems, understand any potential hazards related to the work under consideration, and recognise and avoid any risks involved.

Skilled qualified electrician

Skilled qualified electricians are individuals who have sufficient professional or technical training, knowledge and actual experience to enable them to work on electrical systems, understand any potential hazards related to the work under consideration, and recognise and avoid any risks involved.

2.3 Personal protective equipment

Description of personal protective equipment

Hearing protection



Hearing protection protects against hearing damage resulting from noise exposure.

Industrial safety helmet



Industrial safety helmets protect the head from falling objects, suspended loads, and the effects of striking the head against stationary objects.

Protective clothing



Protective clothing is close-fitting, with low tear resistance, close-fitting sleeves, and no projecting parts.

Protective gloves



Protective gloves protect hands from friction, abrasions, punctures, deep cuts, and direct contact with hot surfaces.

Safety harness



A safety harness protects people from a fall when they are working at height. You are at risk from a fall if the task is at height and if there is no railing in place.

When you put on a safety harness, connect it via an energy-absorbing lanyard to a suitable anchor point.

Safety harnesses must only be used by individuals who have been specifically trained to use them.

Safety shoes



Safety shoes protect the feet against crushing, falling parts, and from slipping on slippery ground.

2.4 Dangers when handling the AHU

Suspended loads

DANGER!

Danger of death due to suspended loads!

Falling loads may cause serious injury or death.

Therefore:

- Never walk under suspended loads.
- Only move loads under supervision.
- Observe the specifications for the intended lashing points.
- Do not attach the lifting gear to protruding machine parts or lugs on attached components
- Ensure that the lifting gear is secure.
- Only use approved hoisting devices and lifting gear with sufficient load-bearing capacity.
- Do not use any frayed or worn ropes and belts.
- Do not place ropes or belts near sharp edges or corners; do not knot or twist.
- Place the load on the ground before leaving the workplace.

Industrial trucks

WARNING!

Danger to life from industrial trucks!

Objects and other loads could fall in an uncontrolled manner from industrial trucks during transport and cause serious injuries or even death. There is also the risk that people will not be seen and could thus be run over by the vehicle driver.

- Industrial trucks may only be operated by trained vehicle drivers (e.g. forklift drivers).
- People should only pass industrial trucks when the vehicle driver has signalled that they have seen them.
- Only approved industrial trucks with sufficient load-bearing capacity may be used.
- Materials should never be transported in the vicinity of people or the zones occupied by people.

Electric current

DANGER!

Danger of death due to electric current!

Danger of electric shock! Do not touch any live components! Damaged insulation or damaged parts are a life threatening hazard.

- Have work on the electrical system carried out only by skilled qualified electricians.
- Have work on the electrical system carried out only by skilled qualified electricians.
- If the insulation is damaged, disconnect the power supply immediately and have the insulation repaired.
- Before you start working on electric systems and equipment, switch off the supply voltage and secure it against being switched on accidentally. Comply with the 5 safety rules:
 - Disconnect.
 - Secure it against being switched on accidentally.
 - Ensure that no voltage is present.
 - Connect to the earth; short circuit connection.
 - Either cover nearby parts that carry a voltage or install barriers.
- Do not bypass or disable any circuit breakers. Be sure to maintain the correct current rating when you replace a circuit breaker.
- Ensure that live parts do not come into contact with moisture. Moisture can cause a short circuit.

Dirt and objects lying around

CAUTION!

Risk of injury from falling as a result of dirt or objects lying around!

Dirt and objects lying around can lead to the risk of slipping and tripping. Injuries can be caused by falling.

- Work areas should always be kept clean.
- Objects that are no longer required should be removed from the work area, particularly those that are near the floor.
- Tripping hazards that cannot be avoided should be marked with yellow and black marking tape.

Tools

CAUTION!

Risk of injury as a result of the negligent handling of tools!

Negligent handling of tools can lead to crushing or cuts.

- Tools must be handled carefully and as intended.
- The weight must be taken into account when transporting tools.
- Protective gloves and safety shoes should be worn.

Rotating parts

WARNING!

Risk of injury from rotating parts!

Rotating parts in the fan can cause serious injuries.

- Do not reach into or tamper with the moving fan wheel during operation.
- Do not open inspection access doors and covers during operation.
- Ensure that the fan wheel is not accessible during operation.
- The fan does not stop immediately! Check that no parts are moving before you open an inspection access door.
- Switch off the system before you start working on movable fan parts and secure it against accidentally being switched on again. Wait until all parts have come to a standstill.

Noise

WARNING!

Hearing damage due to noise!

The noise level in the work area can cause severe hearing damage.

- Always wear hearing protection while working.
- Only remain in the hazardous area if absolutely necessary.

Crushing hazard!

WARNING!

Crushing hazard from movable parts!

There is an increased risk of crushing on casing units, doors, panels and components of the device.

- Never reach between moving parts.
- Be careful when carrying out any work.
- Wear protective gloves, safety shoes and a hard hat.

Inspection access doors slamming shut

WARNING!

Risk of crushing from doors slamming shut

Inspection access doors may slam shut by the wind or if someone pushes them inadvertently, resulting in serious injury to the head and limbs.

- Secure each inspection access door with a hold open device.
- Secure inspection access doors without a hold open device against closing by suitable means.
- Do not reach between the door and door frame.
- Wear protective gloves and a hard hat when you open an inspection access door.

2.5 Behaviour in the event of hazardous situations or accidents

Preventive measures

- Always be prepared for accidents or fire!
- Keep first aid equipment (first aid kit, blankets, etc.) and fire extinguishers close at hand.
- Familiarise personnel with accident reporting, first aid and rescue equipment.
- Keep access paths for rescue vehicles clear.

Measures in the event of accidents

- Trigger an emergency stop immediately, and put the isolator into the “0” position if necessary.
- Implement first aid measures.
- Rescue individuals from the hazardous area.
- Inform the responsible person at the operation site.
- Notify the emergency services.
- Clear access paths for rescue vehicles.

3 Transport and storage

3.1 Delivery of the air handling unit

3.1.1 Delivery type

Depending on its size, the AHU is delivered either completely assembled or in individual components according to the delivery division on square transport timbers or bolted to one-way pallets. The number of parts is shown on a drawing on the package.



To protect against collisions with transport loops, externally assembled components are sometimes delivered loose. These components have to be properly installed and sealed by others.

3.1.2 Symbols on the packaging

The packaging carries the following marks and symbols. Be sure to follow them when you are moving the unit.



The packaging may also carry other symbols, notes, and information. These must also be followed.

Accessories



Fig. 2: Accessories

Packages with this sticker contain AHU accessories.

3.2 Delivery check

Check delivered items immediately after arrival for transport damage and completeness. In case of any damage or an incomplete shipment, contact the shipping company and your supplier immediately. If any parts are missing, have the driver confirm them on the consignment note.

Otherwise the manufacturer will not accept any liability.



See the notes on shipping damage on the packaging or in the shipping papers.

For any claims it is necessary that you follow the procedure below. In each of the following cases do contact TROX before you start installing a unit.

The packaging has been damaged

- Unpack the goods in the presence of the person who has delivered the goods and have them confirm the damage on the shipping order.
- Photograph the damage.
- Report the damage to TROX immediately.

No external damage to packaging, contents damaged.

- Photograph the damage.
- Report the damage to TROX immediately in writing.
- Note that shipping damage must be reported within four days of delivery.

3.3 Transporting packages

3.3.1 Safety notes regarding transport

Improper transport equipment

! WARNING!

Risk to life from using improper transport equipment!

If packages are lifted without adequate transport equipment and if they are not properly secured, they may fall off and lead to fatal injuries.

- Move components only in the position in which they are to be installed.
- Stand clear of suspended loads.
- Do not move additional loads on top of a package.
- Use only the intended lashing points.
- Make sure that no load is imposed on pipes, ducts or cables.
- Use only approved lifting gear and slings that are suitable and sufficient for the load to be carried.
- Do not tie ropes and chains or make knots or place them on sharp edges.
- Use lifting equipment only to lift packages or units, not to push or pull them.
- Ensure that ropes, belts and chains do not twist.
- Ensure that transport equipment has been correctly assembled, fastened and secured before you use it to lift anything.
- Secure all doors, dampers and panels.
- Move packages without any jerky movements and put them down when you leave your workplace.
- Lifting eyes are designed for one-time use only and not for permanently suspending loads.
- Transport tubes are designed for one-time use only and not for permanently suspending loads.

🔗 2.4 'Dangers when handling the AHU' on page 8

Warning: AHU casing units may tip over



! WARNING!

Risk of injury from AHU casing units tipping over!

Tall AHU casing units with a small footprint, e.g. rotary heat exchangers, may easily tip over and therefore pose an increased risk during unloading, transportation and installation.

Be sure to take adequate precautions:

- Use additional means to secure the casing units, e.g. ratchet straps (by others).
- Use only lifting and transport gear designed for the required load.
- Keep the casing units secured against shifting and tipping over until installation is complete.

Unbalanced loads and centre of gravity

! WARNING!

Risk of injury from falling or toppling loads!

Loads may be unbalanced, i.e. the centre of gravity may not be obvious. If the load is not properly attached to the lifting equipment, it may topple and fall. Falling or toppling loads can cause serious injuries.

- Note that the centre of gravity is marked on each package.
- When you use a crane to move loads, ensure that the centre of gravity of the load is directly beneath the crane hook.
- Lift any load carefully and keep an eye on it to see whether it will stay in place. If required, change the lashing point(s).

Sticker indicating the centre of gravity

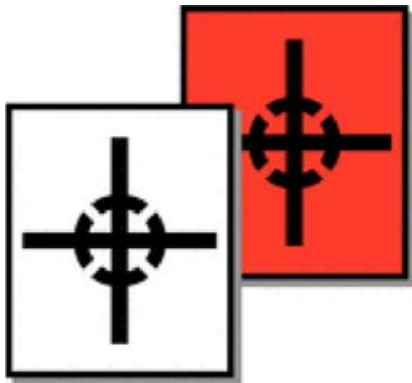

Fig. 3: Shipping stickers

Stickers on the packaging indicate the centre of gravity (Fig. 3).

Sharp edges, sharp corners and thin sheet metal parts

! CAUTION!

Danger of injury from sharp edges, sharp corners and thin sheet metal parts!

Sharp edges, sharp corners and thin sheet metal parts of the heat exchanger or of the cooling or heating coil may cause cuts or grazes.

- Be careful when working on these components.
- Wear protective gloves, safety shoes and a hard hat.

Damage to goods being moved

! NOTICE!

Risk of damage to property due to the incorrect handling or lifting of units!

If you handle or move packages incorrectly, they may topple or fall. This can cause considerable damage to property.

- Do not put down packages hard and do not knock against them with force. Watch out for protruding parts.
- When you are moving units for outdoor installation, be careful that the thin metal roof is not damaged by the lifting gear.

- Forklift driver

Protective equipment:

- Industrial safety helmet
- Protective clothing
- Protective gloves
- Safety shoes

! NOTICE!

Risk of damage to property from forklifts or pallet trucks!

Take proper precautions when you use a forklift or pallet truck to move or lift parts or components of an air handling unit as otherwise they may be damaged.

- If you want to use a forklift to lift a package without a base frame, you need to protect the casing units properly.



Fig. 4: Carrying load with a forklift

- 1 ▶ Drive the forklift forward until the forks (Fig. 4 /3) are fully between the square edge timber sections of the pallet (Fig. 4 /2) and protrude from underneath the base frame (Fig. 4 /1) on the opposite side.
- 2 ▶ Ensure that the load cannot tip.
- 3 ▶ Slowly lift the load and start moving.

3.3.2 Transporting packages with a forklift or pallet truck

Air handling units differ in weight and may have different lashing points. See the order-specific technical documents for details.

Personnel:

3.3.3 Transporting packages with a crane

Lashing points

The AHU casing units have lashing points for crane transport; these lashing points differ depending on the casing unit weight and installation location.

Always move AHU casing units with the transport straps/transport locks in place. Remove straps or transport locks only when the unit has reached its final position.

Casing unit weight	Installation location	Lashing point	Details
≤1500 kg	Inside	Lifting eyes	↻ 15
≤1000 kg	Outside	Eye nuts	↻ 16
>1000 kg ≤3000 kg	Inside or outside	Transport tubes	↻ 17

Lashing points are part of the supply package. If several AHU units are to be moved, you will have to reuse lifting eyes or transport tubes.

Use only the factory lashing points to move AHU casing units. If a unit has to be moved with different equipment, contact TROX beforehand to discuss the details.

Transport straps and transport locks

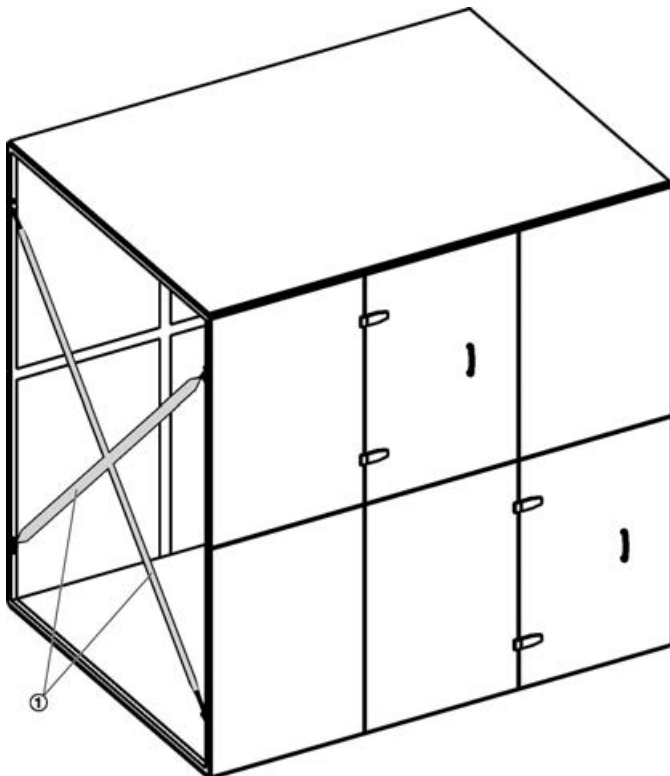

Fig. 5: Transport straps

AHU casing units may be factory-fitted with transport straps (Fig. 5 /1) for extra stability during transport. In addition, the device may also be fitted with inside transport locks.

Using lifting eyes

Personnel:

- Crane driver

Protective equipment:

- Industrial safety helmet
- Protective clothing
- Protective gloves
- Safety shoes



WARNING!

Danger of death from the fall of AHU casing units.

If you overload lashing points or lifting gear, the load may fall down. You or others could be killed.

- Use lifting eyes only to move AHU casing units up to a maximum weight of 1500 kg.
- Use all the lashing points provided.
- Use only adequate lifting gear and slings.
- Stand clear of suspended loads.

- Maintain an angle greater than 45° between the sling and the top of the unit.
- Do not spread slings by more than 60°.
- Ensure that the slings cannot damage the AHU casing unit.
- Suspend (distribute) the load symmetrically, i.e. in such a way that its centre of gravity is beneath the crane hook.



We recommend using a chain hoist and spreader beam in the following cases:

- If the correct angles for the slings cannot be maintained.
- If there are more than four lashing points on a package.

- 4 ▶ Slowly lift the load and start moving.

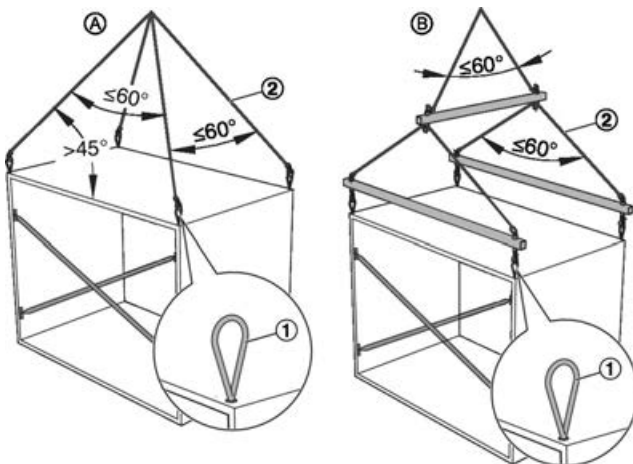

Fig. 6: Using lifting eyes for moving units with a crane

AHU casing unit maximum weight: 1500 kg

- (A) Moving units with ropes/chains
- (B) Moving units with a spreader beam
- (1) Lifting eye
- (2) Slings

- 1 ▶ Remove the covers from the threaded holes in the top corners of the AHU casing unit.
- 2 ▶ Insert all lifting eyes (Fig. 6 /1) completely into the threaded holes.



Several lifting eyes are part of the supply package; if you have used them for moving other AHU casing units, you can reuse them.

- 3 ▶ Hook the slings (Fig. 6 /2) into the lifting eyes.

Note:

Using eye nuts

Personnel:

- Crane driver

Protective equipment:

- Industrial safety helmet
- Protective clothing
- Protective gloves
- Safety shoes

WARNING!

Danger of death from the fall of AHU casing units.

If you overload lashing points or lifting gear, the load may fall down. You or others could be killed.

- Use eye nuts only to move AHU casing units up to a maximum weight of 1000 kg.
- Use all the lashing points provided.
- Use only adequate lifting gear and slings.
- Stand clear of suspended loads.

- Suspend (distribute) the load symmetrically, i.e. in such a way that its centre of gravity is beneath the crane hook.



We recommend using a chain hoist and lifting beam in the following cases:

- If the correct angles for the slings cannot be maintained.
- If there are more than four lashing points on a package.

- ▶ Slowly lift the load and start moving.

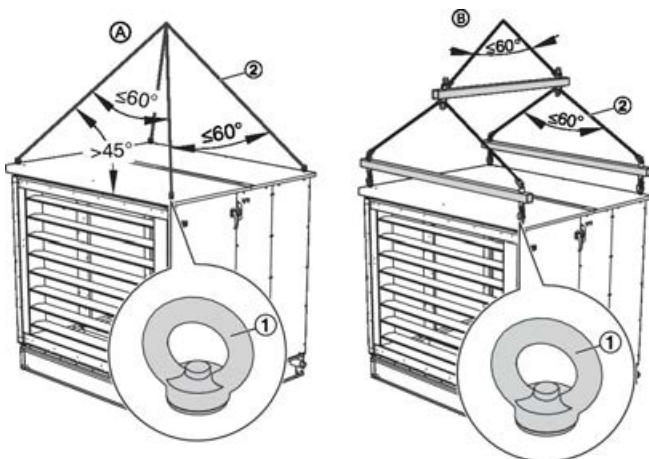

Fig. 7: Using eye nuts for moving units with a crane

AHU casing unit maximum weight: 1000 kg

- (A) Moving units with ropes/chains
- (B) Moving units with a lifting beam
- (1) Eye nut
- (2) Slings

1 ▶



AHU casing units with a roof are factory fitted with eye nuts.

- ▶ Hook the slings (Fig. 7 /2) into the eye nuts.

Note:

- Maintain an angle greater than 45° between the sling and the top of the unit.
- Do not spread slings by more than 60° .
- Ensure that the slings cannot damage the AHU casing unit.

Using transport tubes

AHU casings or casing units that cannot be moved using lifting eyes or eye nuts have to be moved with transport tubes. Transport tubes are part of the supply package. If several AHU units are to be moved, you will have to reuse the transport tubes.

If you have to move AHU casing units at a later stage and do not have the original transport tubes any more, you may use other tubes with the following properties:

Seamless steel tube, S235JR+AR (St 37-2, EN 10025), wall thickness of 5 mm.

Select the right transport tubes for the casing unit weight and width using the tables below.

Diameter of the transport tubes

Outer diameter [mm]	Weight of AHU casing unit [kg]	
	Europe	United Kingdom
48.3	≤ 1500	≤ 960
60.3	≤ 2000	≤ 1590
76.1	≤ 3000	≤ 2650

Weights apply to two transport tubes.

Use more tubes for higher component weights.

Length of the transport tubes

Width of AHU casing unit (inside dimension) [mm]	Length of transport tubes [mm]
612	1058
918	1364
1224	1670
1530	1976
1836	2282
2142	2588
2448	2894
2754	3200
3060	3506
3366	3812
3672	4118
3978	4424
4284	4730
4590	5036
4896	5342

Personnel:

- Crane driver

Protective equipment:

- Industrial safety helmet
- Protective clothing
- Safety shoes
- Protective gloves

WARNING!

Danger to life from falling AHU components!

AHU components can fall down due to overloaded lashing points or lifting gear. There is danger to life.

- When you use transport tubes, be sure to use tubes with the correct diameter for the weight to be moved
 ↪ ‘Using transport tubes’ on page 17 .
- Use all the lashing points provided.
- Use only adequate lifting gear and slings.
- Stand clear of suspended loads.

The number of drilled holes in the base frame (Fig. 8 /6) indicates the number of transport tubes (Fig. 8 /1) to be used.

- Select the lashing points based on the number of transport tubes used, Fig. 8

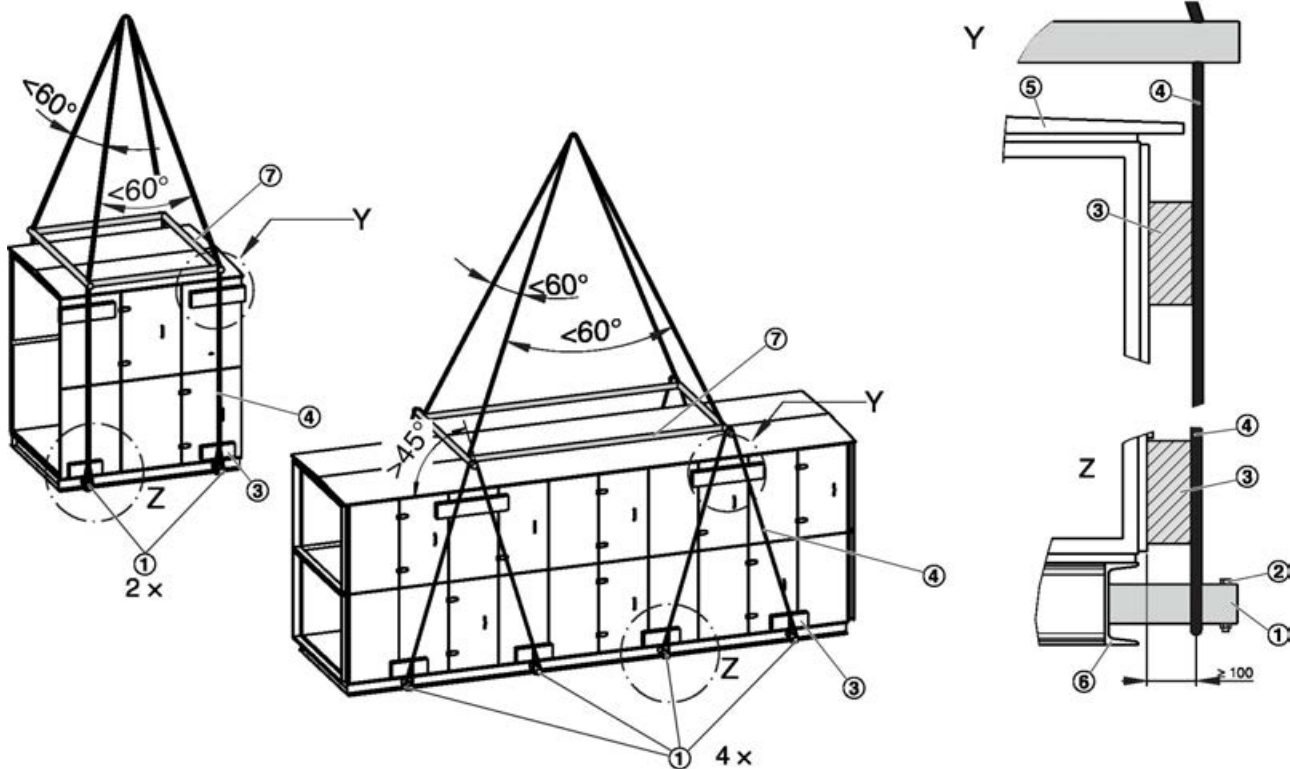

Fig. 8: Lashing points with two or four transport tubes

- 1 ▶ Push transport tubes (Fig. 8 /1) through the drilled holes in the base frame.
 Secure the transport tubes with screws (Fig. 8 /2).

- 2 ▶ Place the slings (Fig. 8 /4) around the ends of the transport tubes.

Position slings between the base frame (Fig. 8 /6) and the screws (Fig. 8 /2).

Protect the edges with wood blocks (Fig. 8 /3). If a unit with a roof (Fig. 8 /5) is to be moved, use wood blocks that are thick enough to provide a distance of 100 mm between the sling and the casing unit.

Spread the slings near the roof with a suitable device (Fig. 8 /7), e.g. a spreader beam.

Note:

- Do not spread slings by more than 60°.
- Ensure that the slings cannot damage the AHU casing unit.
- Suspend (distribute) the load symmetrically, i.e. in such a way that its centre of gravity is beneath the crane hook.

! NOTICE!

Risk of damage to property due to the incorrect handling or lifting of units!

Take proper precautions when using a crane to move or lift parts of an AHU as otherwise they may be damaged.

- Protect the edges of the AHU units with wood blocks.
- Spread the slings (wire ropes or chains) near the roof with a suitable device, e. g., a spreader beam.

- 3 ▶ Slowly lift the AHU load and start moving.

3.4 Storage and functional integrity

3.4.1 Storage

! NOTICE!

Risk of damage to property due to corrosion!

Insufficient ventilation due to film packaging can result in condensation and, hence, oxidation on galvanised surfaces, e.g. white rust.

- Remove film packaging immediately after delivery.
- Store all units in a dry, well-ventilated place.

In the case of Sendzimir-galvanised units, corrosion may occur on the cut edges. Reddish or whitish discolouration of the cut edge does not indicate problematic corrosion. Corrosion protection is still guaranteed. This does not indicate a reduction in quality and there are no grounds for complaint.

Please note the following storage conditions:

- Do not store outdoors.
- Store in a dry and dust-free place that is not exposed to sunlight.
- Storage temperature: -10 °C to +50 °C; avoid sudden/major fluctuations in temperature.
- Provide unpackaged units with protective packaging and ensure sufficient ventilation in order to prevent condensation.
- Seal openings in the units to ensure that no dust or vermin can get inside.

- Do not expose the units to aggressive operating fluids.
- The storage location must be level and have sufficient load-bearing capacity.
- If storing the units for more than 3 months, refer to the information on functional integrity.  on page 19

Note!

If there are storage instructions on the packaging, these instructions must be followed as well.

3.4.2 Functional integrity of components

When storing or shutting down the units or if commissioning is to be carried out at a later date (units out of operation for more than 3 months), take the following measures to ensure their functional integrity.

- Rotating or moving components such as fans, rotary heat exchangers, multileaf dampers, actuators, valves or pumps should be rotated/moved on a monthly basis.
- For belt-driven components, slacken the belts.
- Check the general condition of all parts and of the packaging. Refresh corrosion protection, if necessary.
- Documentation of the measures carried out.

For frequency inverters, EC controllers (period without supply voltage >1 year), additional measures may be necessary. Please refer to the relevant manufacturer documentation.

3.5 Unpacking

Packaging

The packaging depends on how the packages are being shipped. Only environmentally-friendly materials have been used for the packaging.

The packaging is intended to protect the components from damage, including transport damage, and corrosion. Do not destroy the packaging and do not remove it until you are ready to install the components.

ENVIRONMENT!

Note on disposing of single-use packaging

The packaging is purely transport packaging, which has been reduced to the absolute minimum with regard to transport and unloading.

Packaging materials can, in many cases, be reconditioned and recycled.

- Dispose of packaging materials in an environmentally friendly manner in accordance with the local waste disposal regulations.
- If necessary, employ a specialist disposal company to dispose of the packaging.

Transport protection for AHU casing units

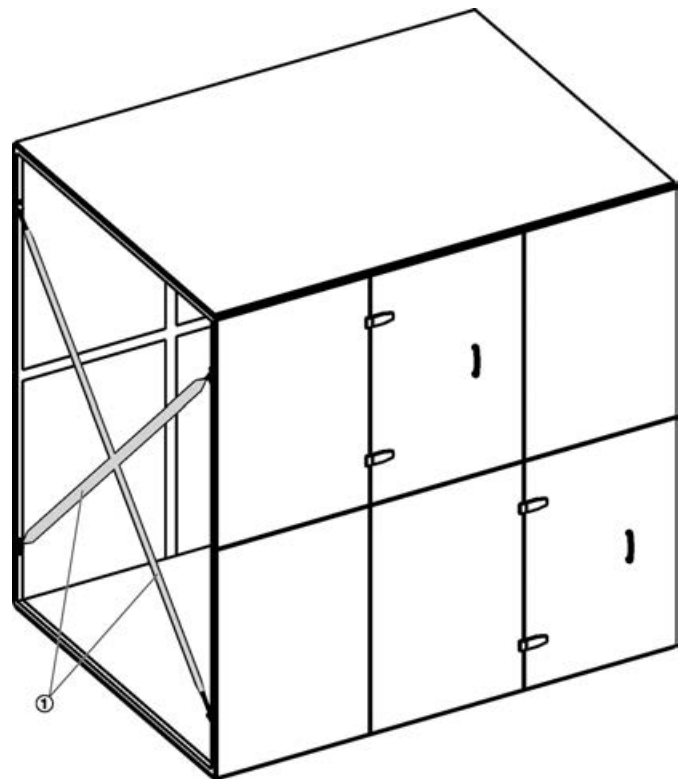

Fig. 9: Transport straps

- 1 ▶ Cut the transport straps (Fig. 9 /1) and remove them completely.

3.5.1 Removing transport locks

Always move AHU casing units with the transport protection devices in place; remove transport protection devices only when the unit has reached its final position.

Transport tubes

If the AHU was transported with transport tubes, these must be pulled out of the base frame.

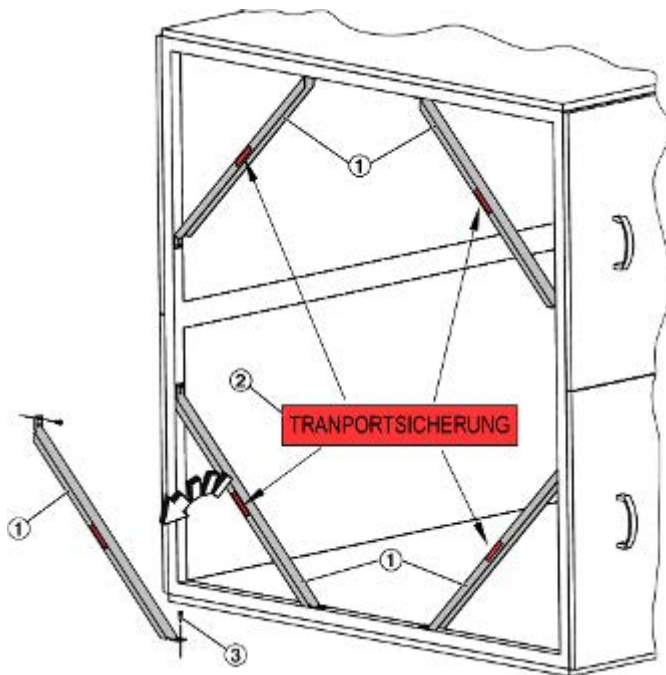

Fig. 10: Cross bars

- 1 ▶ Remove the cross bars (Fig. 10 /1) that are marked with a red sticker (Fig. 10 /2).

Note: Do not remove any of the painted cross bars that do not carry a sticker!

- 2 ▶ Then close the drilled holes in the frame with screws (Fig. 10 /3).

Transport protection device for the fan

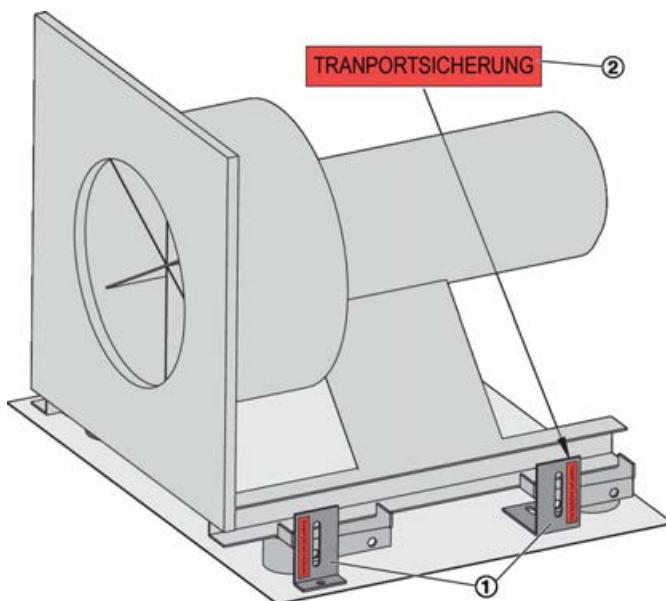

Fig. 11: Transport protection brackets

- 1 ▶ Remove the brackets (Fig. 11 /1) that are marked with a red sticker (Fig. 11 /2).
- 2 ▶ Then close the drilled holes in the floor of the AHU casing with screws and washers.

4 Setup and installation

If an air handling unit is shipped in several parts, you have to erect and assemble it on site. The arrangement of the AHU casing units is given on the order-specific approval drawing.

Conformity assessment

If components or devices which cannot in themselves perform a specific application (partly completed machinery) are incorporated into fully functional machinery, the individual who performs the incorporation or assembly is responsible for the conformity assessment, for creating the declaration of conformity and for attaching the CE mark.

4.1 Safety instructions

Setup and assembly

WARNING!

Risk to life from incorrect setup and assembly!

The incorrect setup and assembly of AHU casing units can lead to potentially fatal situations and cause considerable damage to property. Incorrect setup and assembly will also impair the function of the unit.

- Air handling units must only be set up and assembled by HVAC technicians.

Working at height

WARNING!

Risk of a fall when you work at height!

Working at height without using any fall protection equipment, or using unsuitable or damaged equipment to get up to where you work at height, may lead to yourself or others falling from height; people on the ground may be at risk from falling parts or tools. This can cause serious or even fatal injuries.

- Only use equipment that is suitable, stable and strong enough for the job, maintained and checked regularly.
- Stop materials or objects from falling.
- Wear safety shoes, protective clothing and a hard hat.
- Wear a safety harness.

Interconnecting units and systems

WARNING!

Risk of injury from interconnecting different units or systems!

Connecting an air handling unit to other units or systems (e.g. ductwork, pumps, refrigeration systems) can lead to dangerous situations and eventually cause serious or even fatal injuries.

- If you have to connect other units or systems to the air handling unit, connect them professionally.
- The system owner/HVAC contractor is responsible for the planning and installation of any additional safeguards.

Sharp edges, sharp corners and thin sheet metal parts

CAUTION!

Danger of injury from sharp edges, sharp corners and thin sheet metal parts!

Sharp edges, sharp corners and thin sheet metal parts of the heat exchanger or of the cooling or heating coil may cause cuts or grazes.

- Be careful when working on these components.
- Wear protective gloves, safety shoes and a hard hat.

Inspection access doors slamming shut

WARNING!

Risk of crushing from doors slamming shut

Inspection access doors may slam shut by the wind or if someone pushes them inadvertently, resulting in serious injury to the head and limbs.

- Secure each inspection access door with a hold open device.
- Secure inspection access doors without a hold open device against closing by suitable means.
- Do not reach between the door and door frame.
- Wear protective gloves and a hard hat when you open an inspection access door.

Crushing hazard!**WARNING!****Crushing hazard from movable parts!**

There is an increased risk of crushing on casing units, doors, panels and components of the device.

- Never reach between moving parts.
- Be careful when carrying out any work.
- Wear protective gloves, safety shoes and a hard hat.

4.2 Requirements for the installation location**DANGER!****Risk of injury from an unsuitable installation location!**

Do not install the AHU in a location that can be accessed by everybody.

AHUs may have lockable doors, yet a risk of injury, vandalism, burglary etc. remains.

Install the AHU in a location that can only be accessed by authorised persons.

4.2.1 Requirements for indoor installation**Installation room**

Air handling units designed for indoor installation have to be installed in a room that meets the following requirements:

- The room has been designed in compliance with the applicable building regulations and is suitable for the technical systems to be installed. National standards for plant rooms may also apply.
- The installation room has to be
 - clean
 - dry
 - free from conductive dust particles
 - free from strong electromagnetic fields
 - free from aggressive atmospheres
 - free from frost
 - fitted with a functioning drainage system
- There is sufficient clearance for installing, operating, servicing, and repairing the AHU and all its parts.
 - The maintenance access has to be at least as deep as the unit.
 - The maintenance access must be wide enough so that all inspection access doors can be opened with an opening angle of 90°.
- The structure on which the air handling unit is to be installed must be suitable for the weight and have a level surface (see the order-specific data sheet for the air handling unit).

- Do not use the air handling unit as a structural element or as a roof for a building.
- Do not use the air handling unit in potentially explosive atmospheres.

Escaping water**NOTICE!****Risk of damage to property from escaping water!**

If the water system is not tight, water may escape and cause considerable damage to property.

- Ensure that liquids are channelled away and to a collection device.

Installation room foundation

The installation room foundation must fulfil the following requirements:

- It is horizontal, flat and robust, made of concrete; alternatively, a supporting structure made of steel may be used.
- The frequency of the supporting structure, particularly of a steel structure, is sufficiently different from the excitation frequency of movable components, such as fans, motors, pumps or refrigerant condensers.
- For air handling units with a condensate drain, the supporting structure is at least as high as the drain trap, see [Chapter 5.3 'Sizing and connecting the condensate drain'](#) on page 42
- If additionally structure-borne noise is to be attenuated (e.g. by rubber or elastomer sheets underneath the air handling unit), be sure to exactly align all AHU casing units (check for door closure, properly sealed joints).

4.2.2 Requirements for outdoor installation**Installation location**

For outdoor installation please note:

- Do not use the air handling unit in potentially explosive atmospheres.
- The installation location has to be
 - free from conductive dust particles
 - free from strong electromagnetic fields
 - free from aggressive atmospheres
 - fitted with a functioning drainage system
- The structure on which the air handling unit is to be installed must be suitable for the weight and have a level surface (see the order-specific data sheet for the air handling unit).

- There is sufficient clearance for installing, operating, servicing, and repairing the AHU and all its parts. The maintenance access has to be at least as deep as the unit.
- Make sure that the installation location meets local regulations to prevent the fall of people, and of tools and other objects.
- Use suitable fall arrest equipment.
- Prevent unauthorised individuals from accessing AHU casing units.
- Make sure that authorised individuals can access AHU casing units safely.
- Keep the structural properties in mind and make sure the maximum roof load is not exceeded; do not neglect the effects of weather on the unit (rain, snow, wind, sun etc.).
- The stability of the device at the installation site must be ensured; we recommend that proof of stability with regard to wind load and other external influences be provided, e.g., by means of a wind load calculation. Depending on the expected wind load, the device must be fixed to the foundation/support structure or braced with suitable components.
- Only a skilled qualified professional must connect the air handling unit to an external switch cabinet and prevent the cables from the effects of weather (rain, snow, wind, sun etc.).
- All heat transfer fluid pipes and hoses and the AHU components to which they are connected must be frost-proof.
- Do not use the air handling unit as a structural element or as a roof for a building.

Foundation of the outdoor installation area

- The information regarding the foundation of the installation room applies, ↗ *'Installation room foundation'* on page 23
- For roof installation, check the load capacity and support structure of the roof; consult an engineer if necessary
- The entire air handling unit must be supported by a continuous steel structure.
- The steel girders must be designed for a maximum deflection of $L/500$ under load (L = girder length). A maximum deflection of 10 mm under load must not be exceeded
- Waterproof the edge of the roof under the air handling unit and also any connections penetrating the roof.
- Insulate the plinth structure (by others) to prevent condensation.
- In areas with heavy snowfall, choose an installation location where snow will not affect the operation of the air handling unit. Make sure that the supporting structure is high enough.

Escaping water

! NOTICE!

Risk of damage to property from escaping water!

If the water system is not tight, water may escape and cause considerable damage to property.

- Ensure that liquids are channelled away and to a collection device.

4.3 Preventing vibration and structure-borne noise

Anti-vibration elements or a noise insulating layer underneath the air handling unit may help to reduce the transmission of vibration from the air handling unit to the supporting structure:

- If the air handling unit is to be installed on level ground with no special requirements regarding structure-borne noise insulation, we recommend placing rubber or elastomer sheets between the air handling unit and the foundation.
- For noise insulation, compare the requirement to the sound power level of the air handling unit (see order-specific data sheet for the air handling unit) and have the necessary measures determined by an acoustics engineer.

! NOTICE!

Risk of damage to the AHU

Anti-vibration elements or a noise insulating layer must not affect the structural safety of the AHU.

Ensure the following:

- Use a sufficient number of anti-vibration elements and noise insulating layers and place them correctly as otherwise the frame may sag.
- Keep in mind that the various AHU casing units differ in weight; this must not lead to any height differences in the overall unit.

We recommend you to have noise insulating layers (including material and layout plan) selected and sized by an expert company.

4.4 Setting up and assembling the AHU/components

Personnel:

- HVAC technician

Protective equipment:

- Industrial safety helmet
- Hearing protection
- Protective gloves
- Safety shoes
- Safety harness

4.4.1 Setting up the AHU/AHU casing units

Checking the seals on AHU casing units

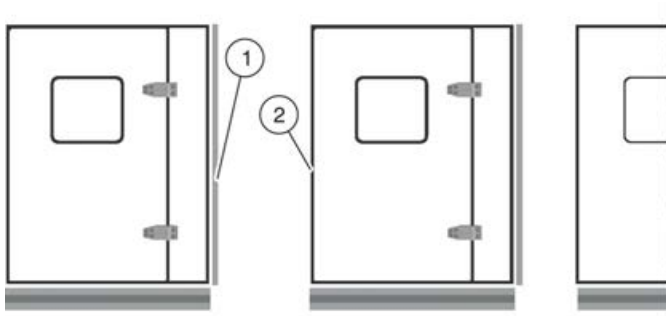

Fig. 12: Seals on AHU casing units

Where two AHU casing units are to be joined, a perimeter seal (Fig. 12 /1) is provided. Note that only one of the units to be joined is fitted with a seal. The other unit does not have a seal (Fig. 12 /2).

1 ▶

i Compressed seals will recover fully to their original state about 60 minutes after the transport protection devices have been removed.

- ▶ Check that the seals are complete and intact and that they seal properly.

Setting up AHU casing units

Slide plates (Fig. 13 /3) considerably simplify the process of positioning the AHU casing units (Fig. 13 /1) on a surface with a high friction coefficient, such as rubber or elastomer sheets (Fig. 13 /4).

i The arrangement of the AHU casing units is given in the order-specific approval drawing.

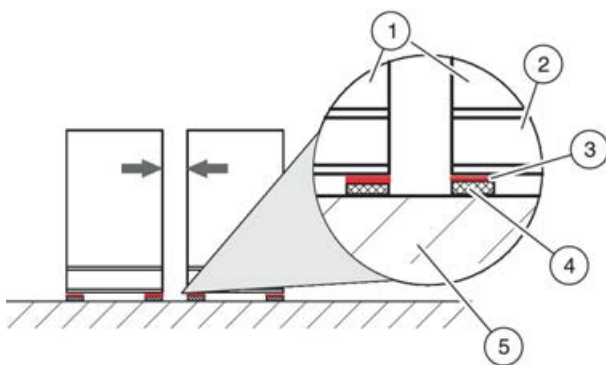

Fig. 13: Unit arrangement with anti vibration elements

- 1 ▶ Position the slide plates (Fig. 13 /3, by others) under the base frames (Fig. 13 /2) of the AHU casing units (Fig. 13 /1).

- 2 ▶ Move the AHU casing units as close together as possible.

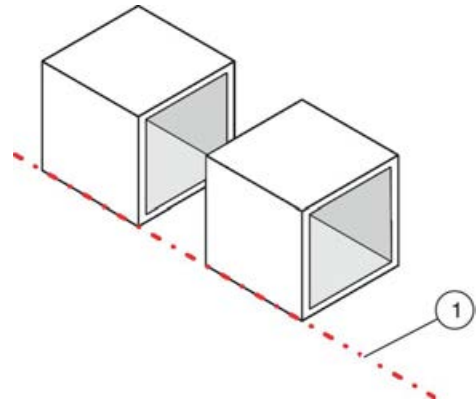

Fig. 14: Aligning AHU casing units

- 3 ▶ Align the AHU casing units so that they are flush with one another (Fig. 14 /1).

i **AHU units with X-CUBE Control:**
Before you push the AHU casing units together, insert the internal cables of each unit into the cable ducts of the next casing unit; for more information see Chapter 5.7 'Wiring' on page 50 .

Setting up units with a base frame

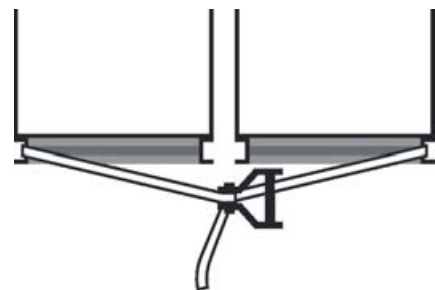

Fig. 15: Attaching a ratchet strap

- 1 ▶ Attach a ratchet strap to the base frames of two AHU casing units (Fig. 15).
- 2 ▶ Tighten the ratchet strap.
 - ⇒ The AHU casing units come closer together as you tighten the strap around the base frames.

Alternatively:

Setting up units without a base frame

- 1 ▶ Attach a ratchet strap to the bottom or top areas of two AHU casing units.
- 2 ▶ Tighten the ratchet strap.
 - ⇒ The AHU casing units come closer together as you tighten the strap.

4.4.2 Assembling AHU casing units

Before assembly

- Remove all transport tubes and transport protection devices from the AHU casing units.
- Have all the required tools ready.
- Have all the applicable documents at hand.
- Remove all separately supplied materials and accessories from the AHU casing units.



Compressed seals will recover fully to their original state about 60 minutes after the transport protection devices have been removed.

Joining AHU casing units with screws/bolts

! NOTICE!

Risk of damage to property from incorrect assembly!

Be sure to assemble the AHU casing units correctly as otherwise the condensate drain may be damaged.

- Protect the condensate drain from damage.

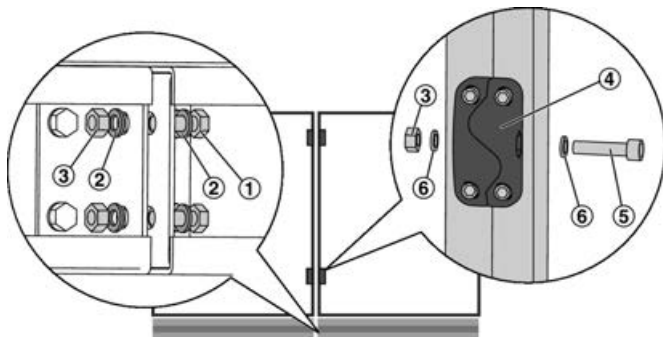

Fig. 16: Joining the base frames with screws/bolts

- ① Hexagon head screws
- ② Washers
- ③ Nuts
- ④ Module connectors
- ⑤ Allen screws
- ⑥ Schnorr® washers

- 1 ▶ Use screws/bolts to join the casing units at the base frame and at the module connectors.

Installing AHU casing units on top of each other

Do not start assembling the upper units until you have completed assembly of the lower units, including screw-fixing the module connectors and the base frame.

Follow the assembly instructions carefully as otherwise the unit may become damaged, the casing units may start shifting or, if the unit is installed outdoors, water may get into the unit.

- Factory drilled holes indicate where the lower and upper AHU casing units have to be joined. Align and fix the casing units according to these holes.
- Be sure to use all of the fixing points. If an assembly point is difficult to access, check if it is possible to assemble the units in a different order.
- Ensure that the position is correct based on the screw joints on the operating side.
- Ensure that no water can get into the unit at the factory provided joints.
- If in doubt, consult with TROX.

- 1 ▶ Use lifting gear, e.g. a crane, to lift the upper casing units onto the lower casing units (see approval drawing). If there are several AHU casing units, assemble the individual units first before you put up additional units.

Without intermediate frame

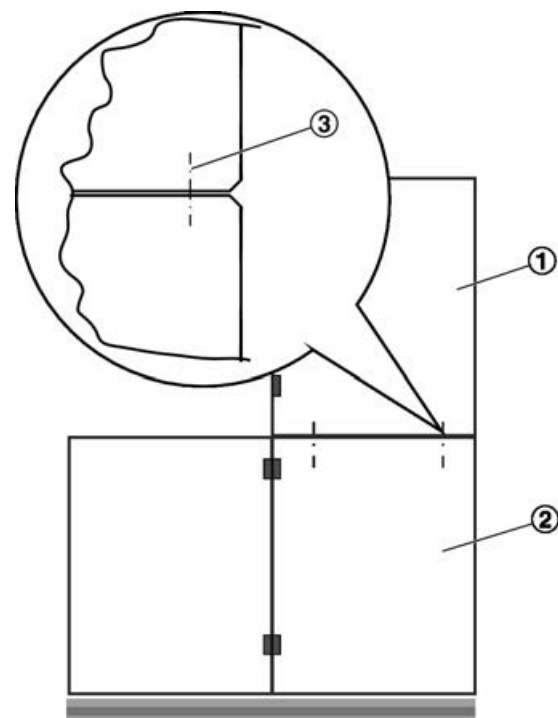

- 2 ▶ Screw-fix (3) the floor panel of the upper casing unit (1) to the ceiling panel of the lower unit (2).

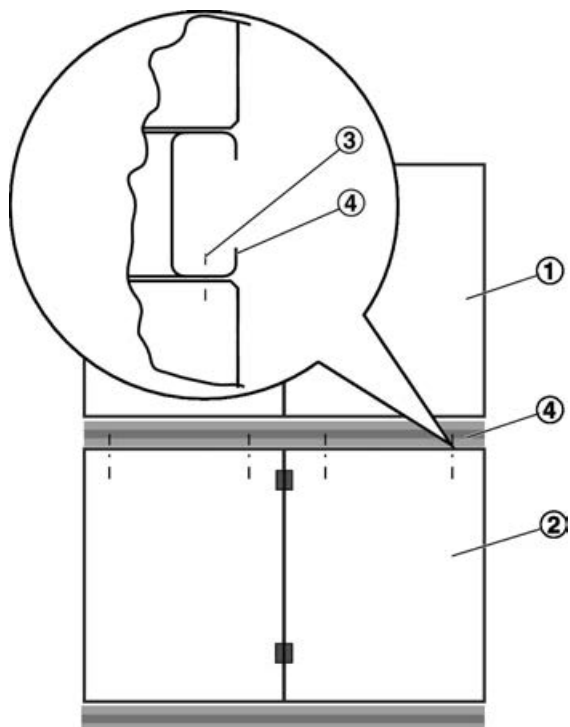
With intermediate frame

- 3 ▶ Screw-fix (3) the intermediate frame (4) of the upper casing unit to the ceiling panel of the lower unit (2).
- 4 ▶ If there are several upper casing units, join the module connectors and the frames with screws, *☞ 'Joining AHU casing units with screws/bolts' on page 26*

Installing the noise insulating connector

If the noise insulating connector has been supplied separately, install it once the AHU has been erected and assembled. Depending on the AHU construction variant the noise insulating connector has to be attached to the AHU itself or to a multileaf damper.

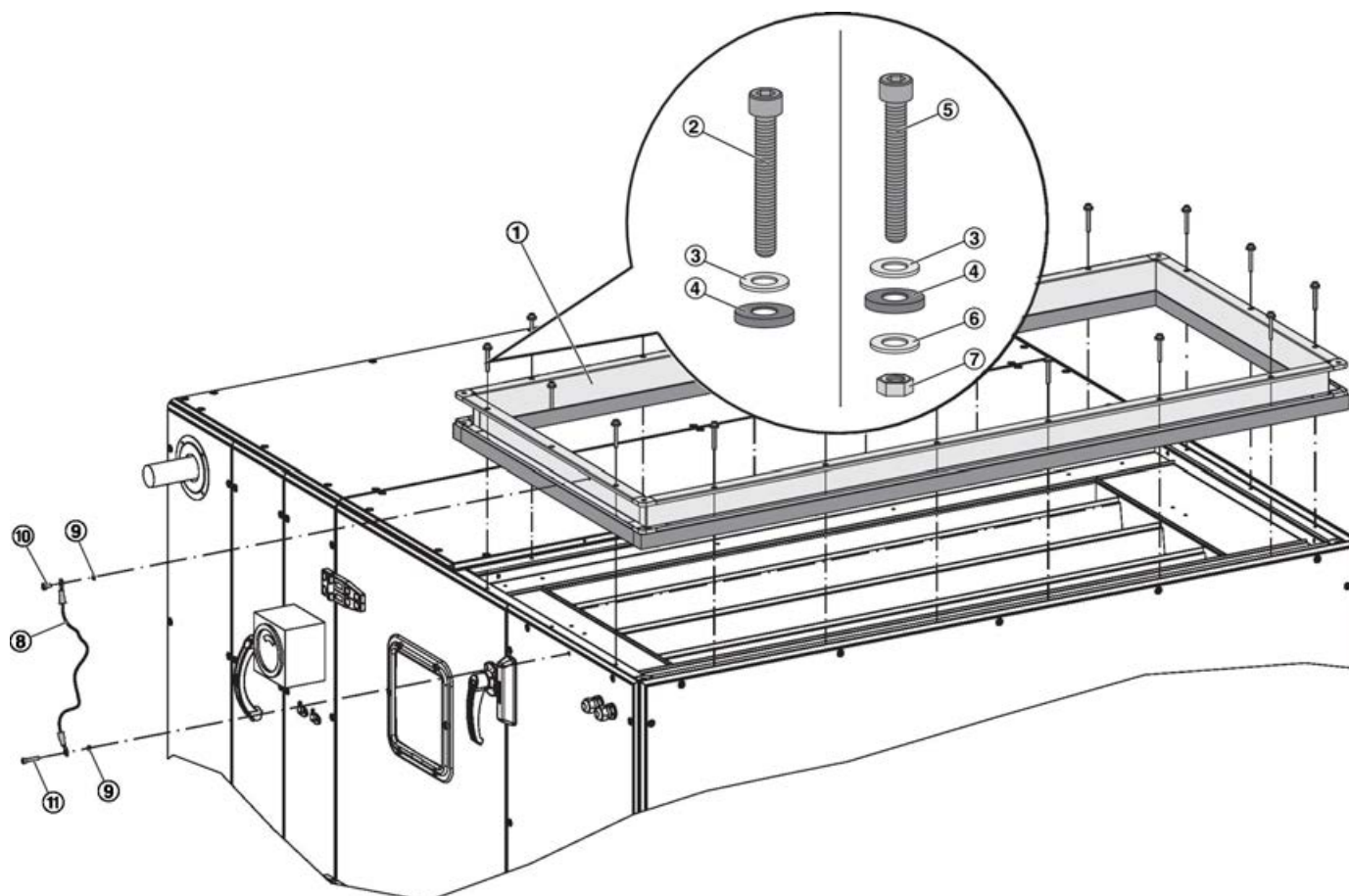

Fig. 17: Installing the noise insulating connector

Supplied assembly material

Item	Description	Part no.			
		Air handling unit		Multileaf damper	
		Galvanised steel	Stainless steel	Galvanised steel	Stainless steel
①	Noise insulating connector				
②	Thread forming socket cap head screw M6 × 40	A00000055910	A00000055911	–	–
③	Washer Ød 6.4	M332AA3	M333AA3	M332AA3	M333AA3
④	Rubber seal 17 × 6.5 × 3	M338BD0			
⑤	Socket cap head screw M6 × 40	–	–	A00000018868	A00000056190
⑥	Washer Ød 6.4	–	–	M332AF9	M333AC3
⑦	Nut M6	–	–	M332AD6	M323AA3
⑧	Ground cable	A00000026651			
⑨	Lock washer, serrated	M332KB4	A00000045194	M332KB4	A00000045194

Item	Description	Part no.			
		Air handling unit		Multileaf damper	
		Galvanised steel	Stainless steel	Galvanised steel	Stainless steel
⑩	Pan head screw M6 × 12	M852AC6			
⑪	Socket cap head screw M6 × 30	M852AC4			

- Place the noise insulating connector (Fig. 17 /1) on the air handling unit with the perimeter seal facing down; fix it with thread forming screws (Fig. 17 /2), rubber seals (Fig. 17 /4) and washers (Fig. 17 /3).



Attaching the noise insulating connector to a multileaf damper

If the noise insulating connector is to be attached to a multileaf damper, fix it with the supplied socket cap head screws (Fig. 17 /5), rubber seals (Fig. 17 /4), washers (Fig. 17 /3 and 6) and nuts (Fig. 17 /7).

- Fix one eye of the ground cable (Fig. 17 /8) with a pan head screw M6 × 12 (Fig. 17 /10) and a serrated lock washer (Fig. 17 /9) to the noise insulating connector.



NOTICE!

Electrical conductivity

For electrical conductivity the serrated lock washer needs to be fitted between the eye of the ground cable and the coated surface.

- Fix the other eye of the ground cable with a socket cap head screw M6 × 30 (Fig. 17 /11) and a serrated lock washer through the panel sheet to the tubular frame of the air handling unit.

4.4.3 Installing the plate heat exchanger

If the plate heat exchanger is supplied separately, you have to install it into the AHU casing unit at the installation location.

Note on split plate heat exchangers:

Assemble the plate heat exchanger before you install it in the AHU (see the documentation of the heat exchanger manufacturer).

The assembly steps are different for each AHU variant:

- Airflows on top of each other, ↻ 30
 - Vertical plate heat exchanger
- Airflows next to each other, ↻ 34
 - Horizontal plate heat exchanger

Airflows on top of each other

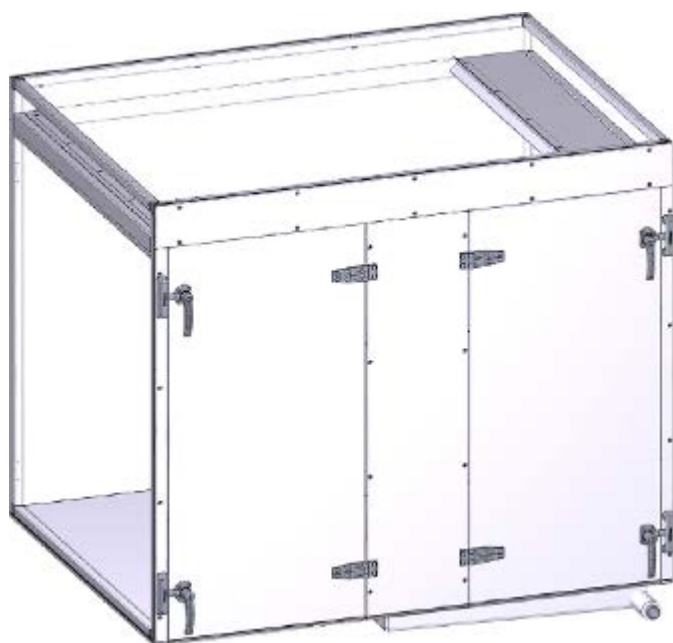

- 1 ▶ Position the lower AHU casing unit for the plate heat exchanger at the installation location.

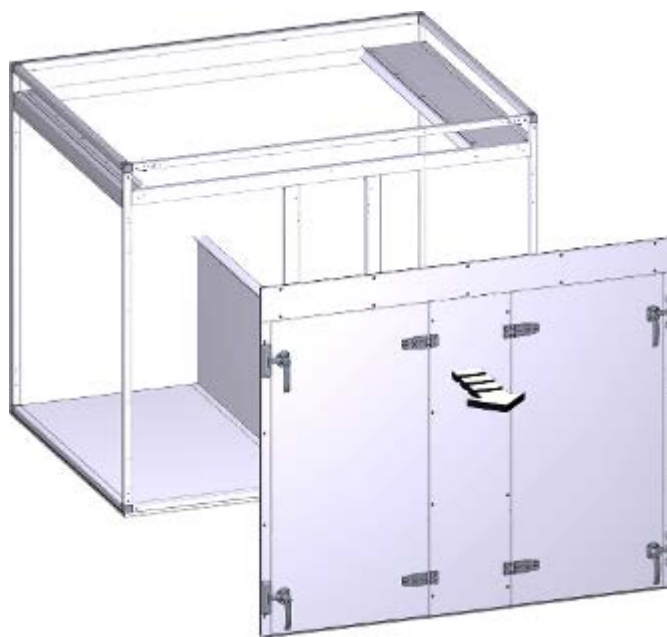

- 2 ▶ Remove doors and panels.

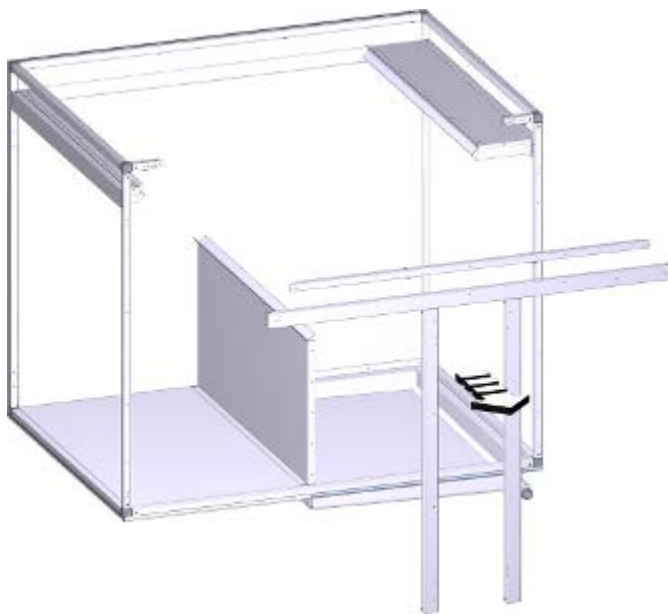

- 3 ▶ Remove the frame sections.

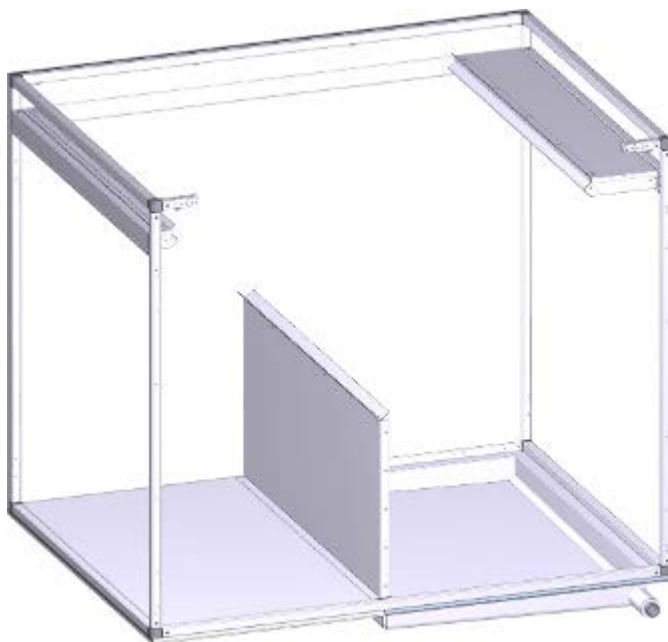

⇒ What it looks like after steps 1 - 3

Installing the heat exchanger

- 4 ▶ If the plate heat exchanger consists of blocks that have been supplied individually, you have to assemble them before you can install the heat exchanger in the AHU casing unit. See the documentation from the plate heat exchanger manufacturer (appendix).

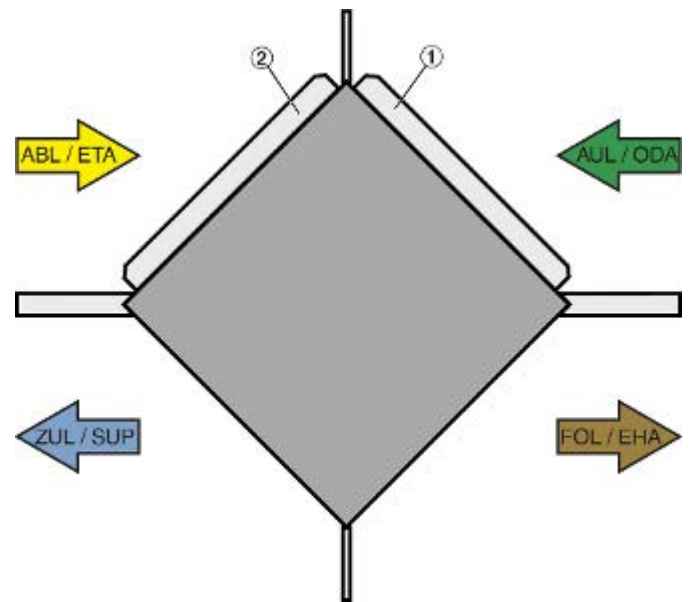

- 5 ▶ Ensure that the bypass damper (1) and the recirculation damper (2), if any, are in the correct position. The bypass damper has to face the outdoor air flow, the recirculation damper has to face the extract air flow.

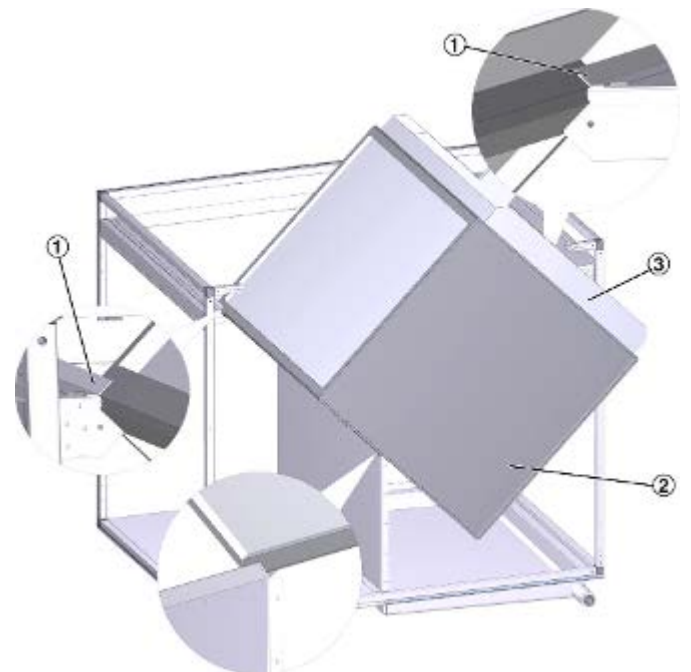

- 6 ▶ Remove the two brackets (1).
Place the heat exchanger (2) in front of the AHU casing unit (e.g. with a forklift), then push it onto the guiding rails (bottom and sides, see detail views). Ensure the correct position of the bypass damper (3)!

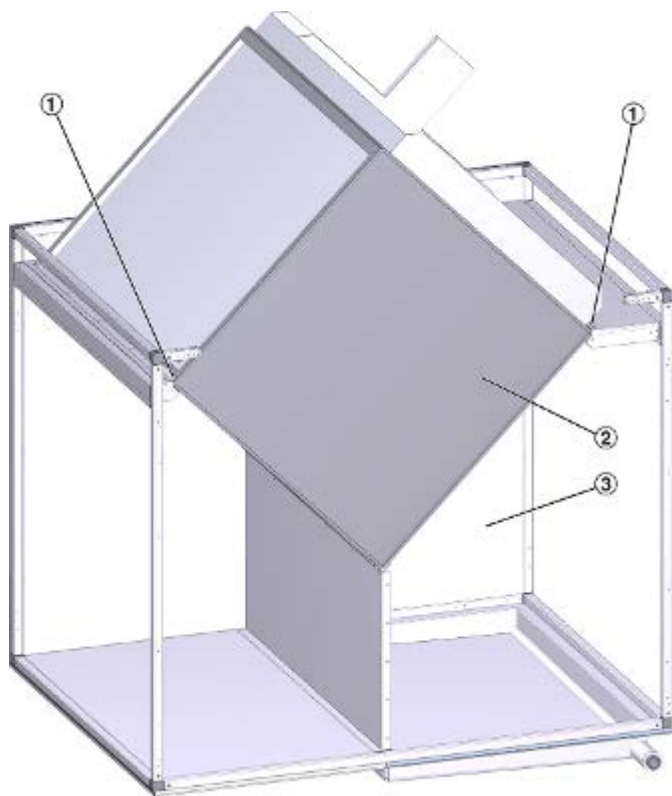

- 7 ▶ Push the plate heat exchanger (2) in and to the back of the casing unit (3). Fit the two brackets (1).

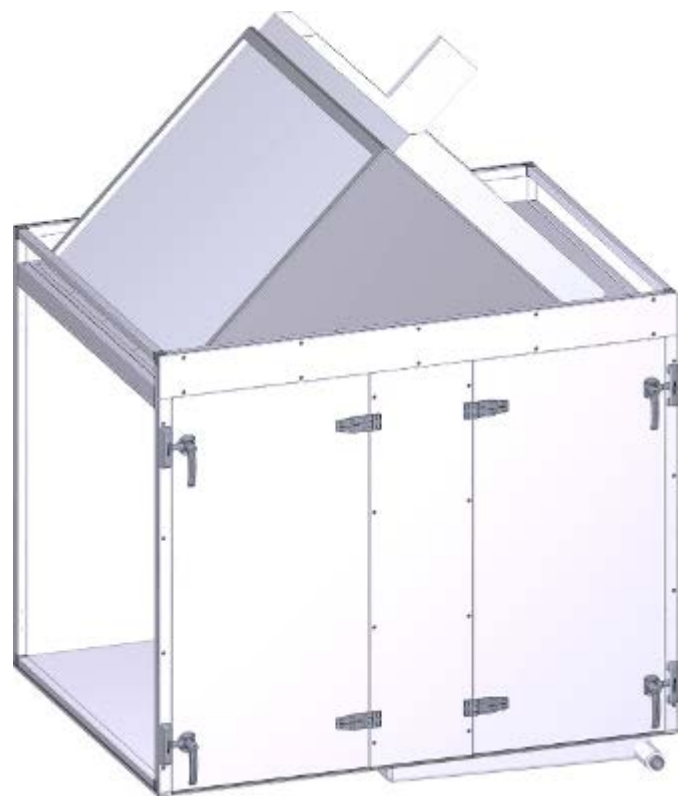

- 9 ▶ Install panel and doors.

Installing the upper AHU casing unit

i Put the upper casing unit from above onto the lower casing unit

If there is enough space above the AHU, the entire casing unit can be put from above, e.g. with a crane, onto the lower casing unit that contains the heat exchanger. In this case you may continue with step 13.

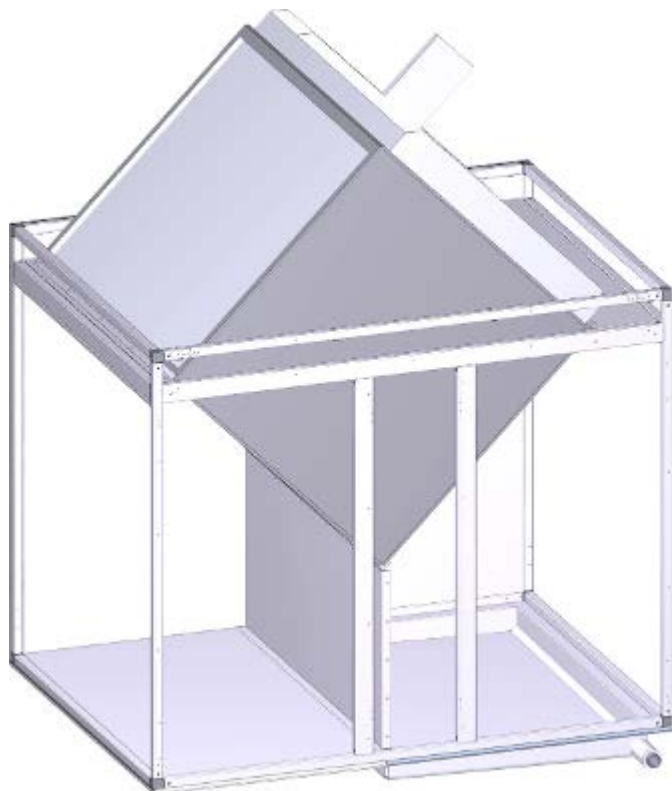

- 8 ▶ Install the frame sections.

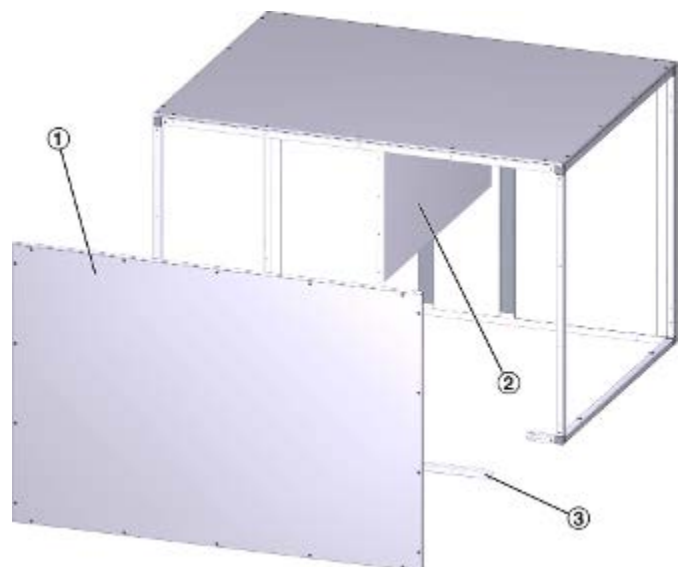

- 10 ▶ Remove the back panel (1) and the frame section (3) from the upper AHU casing unit. If necessary, remove the sealing sheet (2).

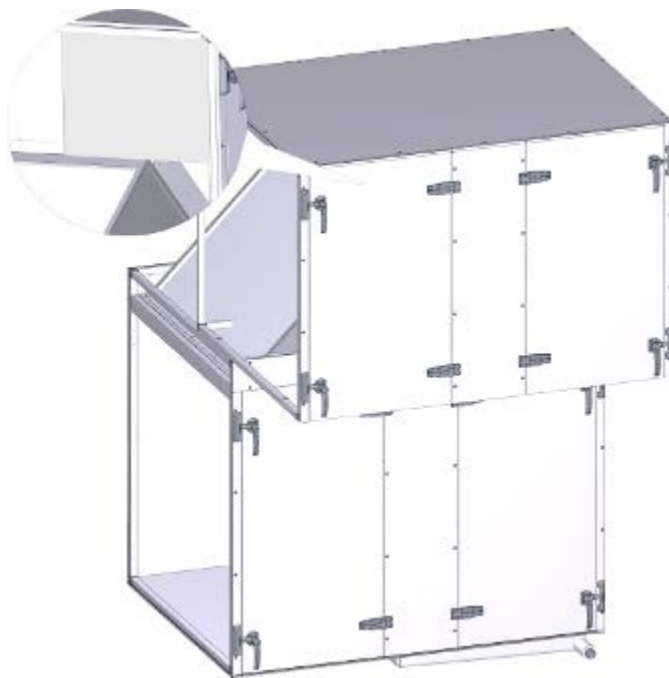

- 11 ▶ Stand on the operating side and push the upper casing unit onto the lower casing unit.



Pushing the upper casing unit from the back onto the lower casing unit

If there is not enough space on the operating side of the AHU (enough space: unit depth), you may also push the upper casing unit from the back onto the lower casing unit that contains the plate heat exchanger. In this case you have to remove the doors, panels and frame sections on the operating side of the upper casing unit.

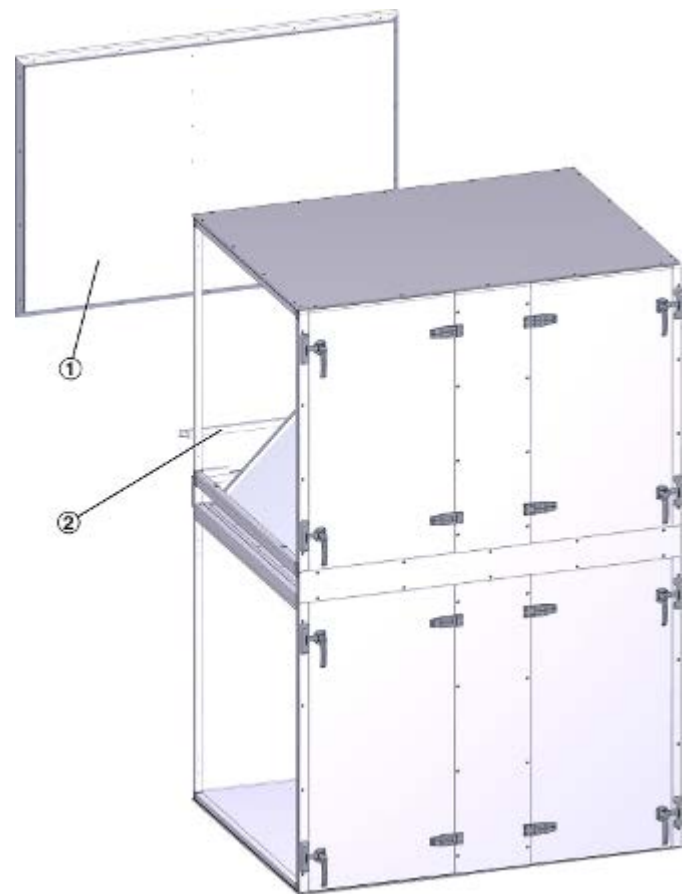

- 12 ▶ Install the frame section (2) and the back panel (1).

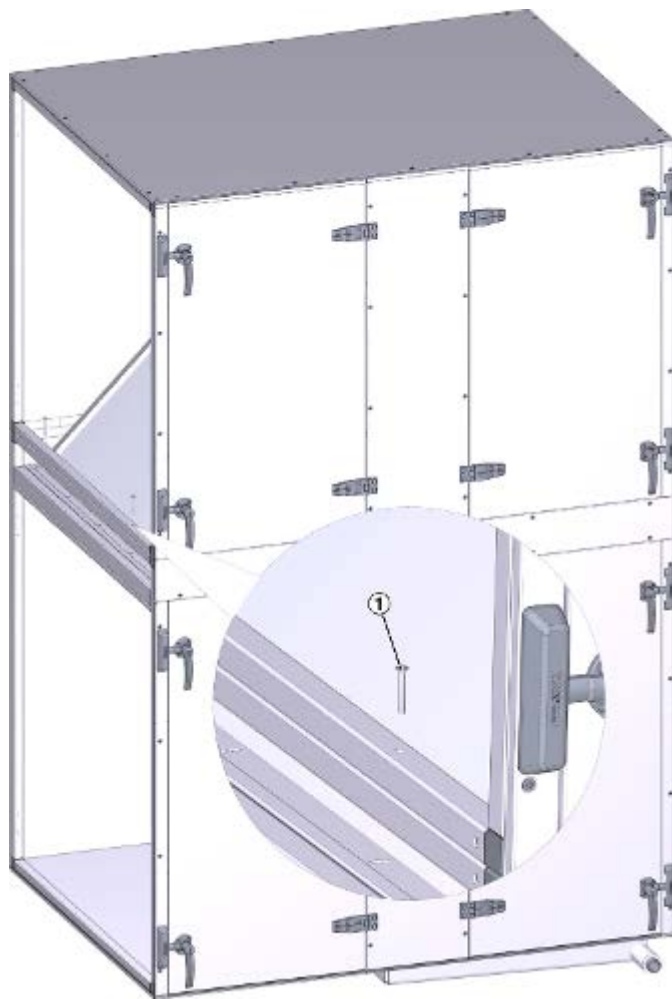

- 13 ▶** Join the upper and the lower casing units with raised countersunk self tapping screws (1) (M6 x 40, part of the supply package).
- ⇒ Installation of the plate heat exchanger is complete. You can now install the adjacent AHU casing units.

Airflows next to each other

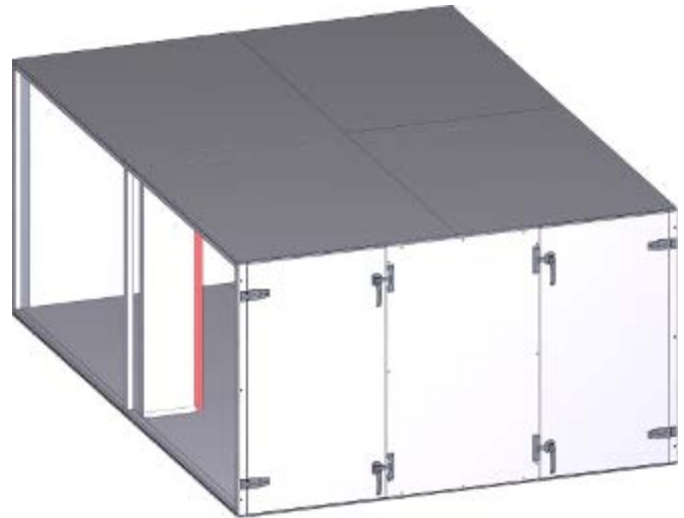

- 1 ▶** Position the AHU casing unit for the plate heat exchanger at the installation location.

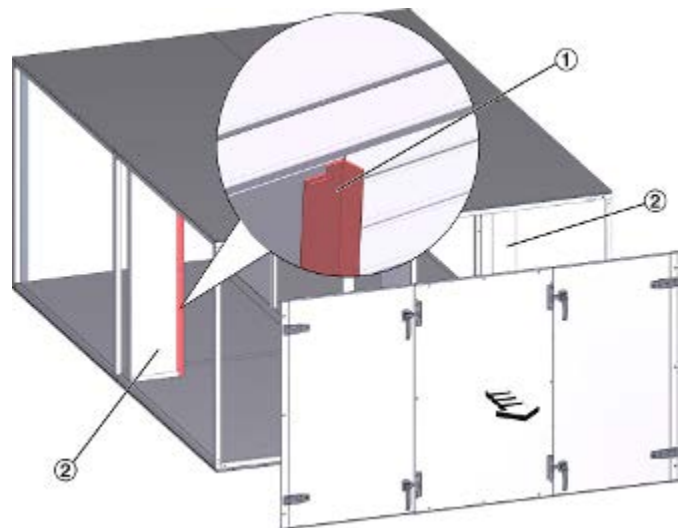

- 2 ▶** Remove doors and panels on the side facing the bracket (1) if at all possible.



If this is not possible, you can also install the plate heat exchanger from the opposite side, i.e. complete the installation steps on the other side. In this case you also have to remove the intermediate panels in step 5.

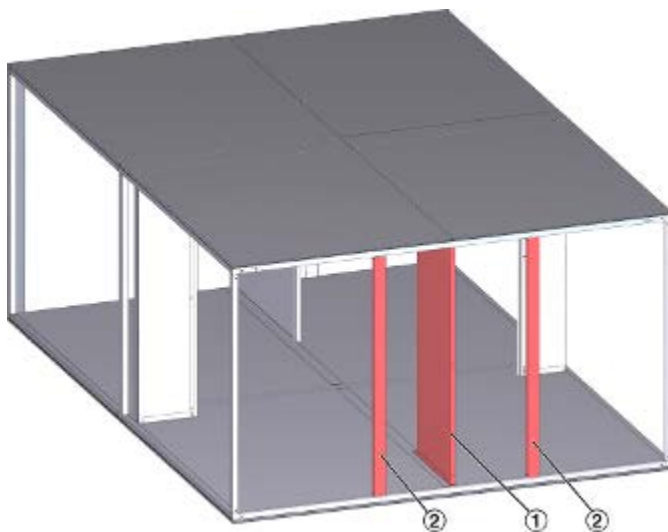

- 3 ▶ Remove the sealing sheet (1) and the frame sections (2).

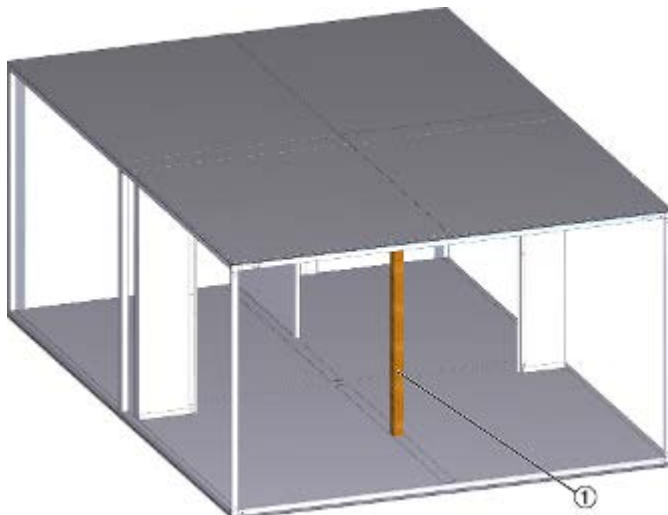

- 4 ▶ Support the roof panel, e.g. with a timber stud.

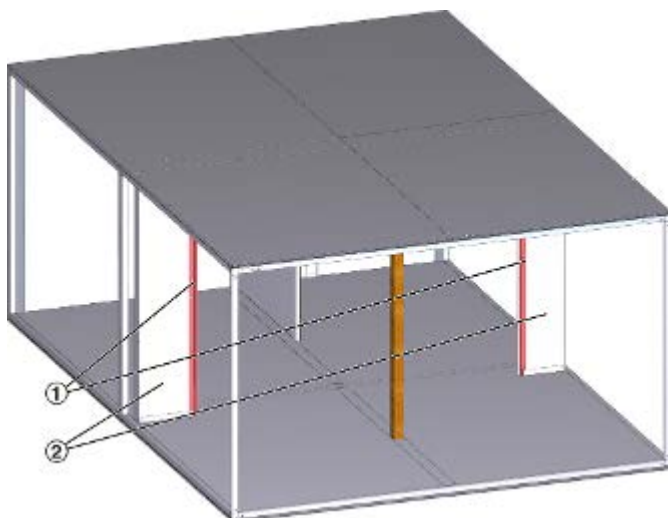

- 5 ▶ Remove the two brackets (1).

Note: If you want to install the heat exchanger from the opposite side, you also have to remove the two intermediate panels (2).

Installing the heat exchanger

- 6 ▶ If the plate heat exchanger consists of blocks that have been supplied individually, you have to assemble them before you can install the heat exchanger in the AHU casing unit. See the documentation from the plate heat exchanger manufacturer (appendix).

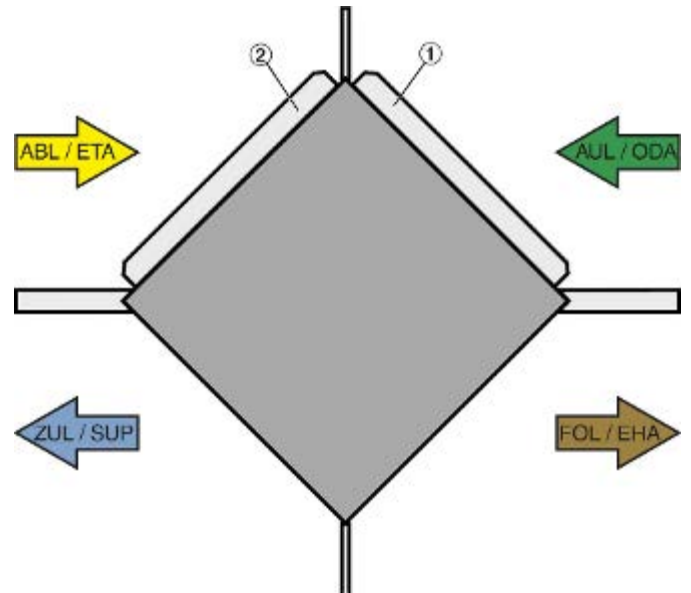

- 7 ▶ Ensure that the bypass damper (1) and the recirculation damper (2), if any, are in the correct position. The bypass damper has to face the outdoor air flow, the recirculation damper has to face the extract air flow.

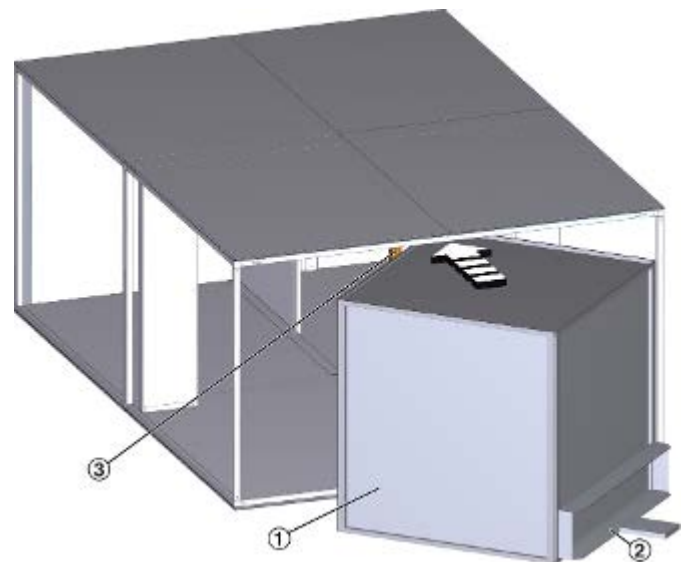

- 8 ▶ Move the plate heat exchanger (1) into the AHU casing unit, e.g. with a forklift truck. Ensure the correct position of the bypass damper (2). Remove the prop (3).

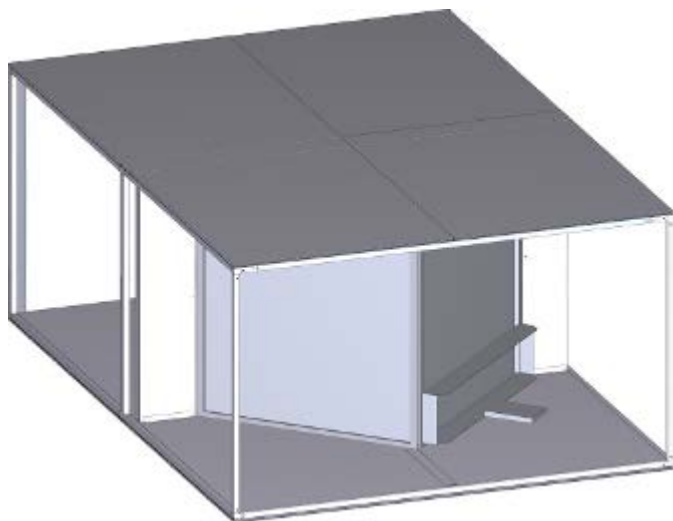

- 9 ▶ Push the heat exchanger further into the AHU casing unit until the tip of the heat exchanger touches the sealing sheet at the back.

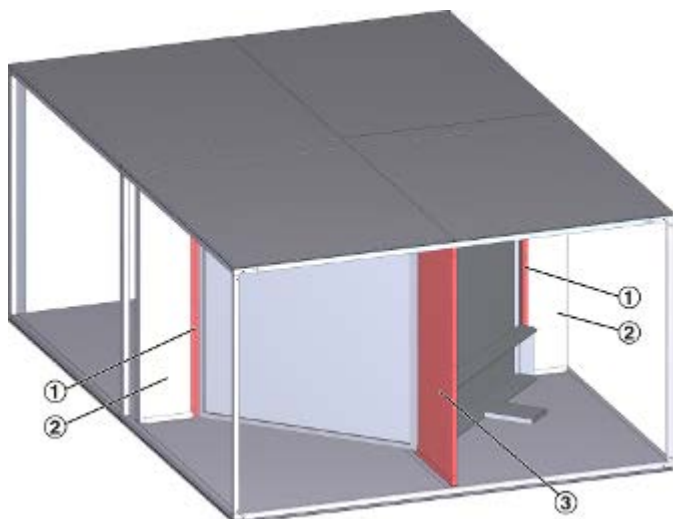

- 10 ▶ Install the two brackets (1) and the front sealing sheet (3).
If you removed the intermediate panels (2) earlier, you now have to re-install them.

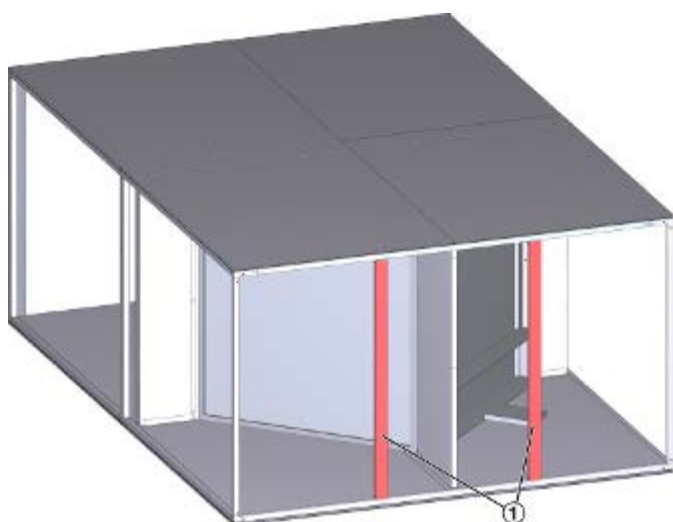

- 11 ▶ Install the frame sections (1).

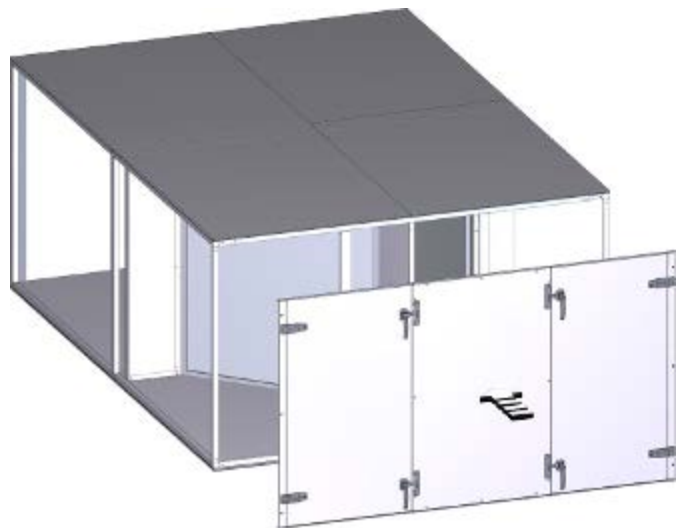

- 12 ▶ Install panel and doors.

⇒ Installation of the plate heat exchanger is complete. You can now install the adjacent AHU casing units.

Installing the actuator on the bypass damper of the plate heat exchanger

Material:

- Actuator with clamping device and anti-twist facility

Preparation:

- Turn the actuator as far as it goes, i.e. up to the travel stop.
- Close the bypass damper manually.



Fig. 18: Preparing installation

- 1 ▶ On the bypass damper of the plate heat exchanger break off the metal cover strip (1) on the mullion between the dampers and remove the screws (2).



Fig. 19: H adapter with horizontal drive shaft

- 2 ▶ Mount the H adapter (1) and the drive shaft (2).

The position of the drive shaft (2) may vary depending on the installation orientation of the plate heat exchanger.

Important: If the shaft is vertical, it has to face upwards; if necessary, turn the H adapter (1) by 180° and then fix it.

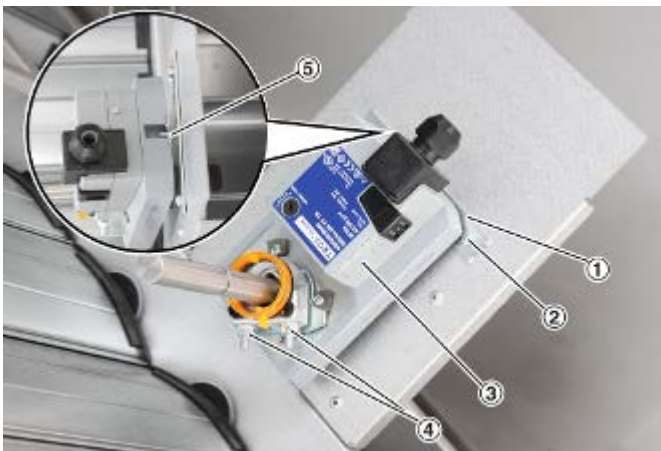

Fig. 20: Installing the actuator

- 3 ▶ Note:
- Install the actuator as close to the H adapter as possible.
 - The axis has to be perpendicular to the H adapter.

Push the clamping device of the actuator (3) onto the shaft and hold the anti-twist device (1) such that it cannot move. Ensure that the bolt (5) engages with the actuator casing. Fix the anti-twist device with 2 screws, e.g. self-drilling screws (2).

Fix the clamping device to the shaft by tightening the nuts (4).

Support the electrical cable with a wire clamping bracket.

⇒ Installation of the actuator is complete.

4.4.4 Additional assembly steps for outdoor units

Connecting the roof segments

Air handling units for outdoor installation require the following additional assembly steps:

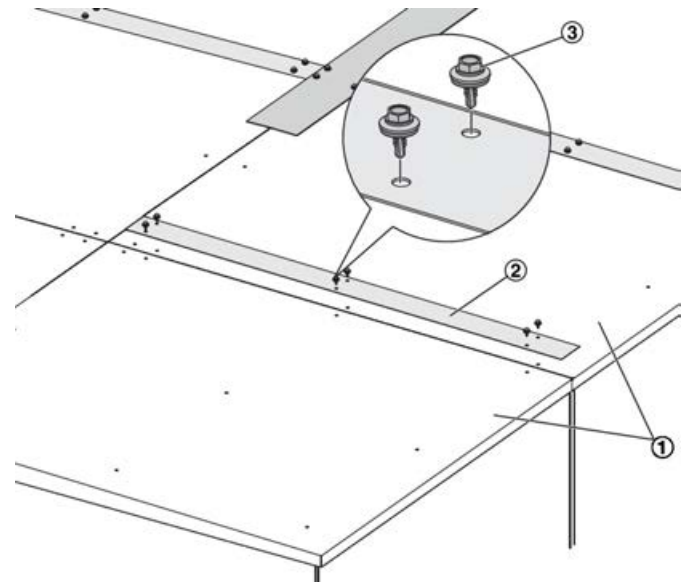

Fig. 21: Joining roof segments

- ① Roof segments
- ② Cover strips
- ③ Self-drilling screws with sealing washers
- ④

- 1 ▶ Connect all joints between the roof segments (Fig. 21 /1) with cover rails (Fig. 21 /3), and fix cover rails with drilling screws (Fig. 21 /4).

! NOTICE!

Remove the eye nuts where the casing units are to be joined so that you can actually join the roof segments. Do not remove the other eye nuts; they have to remain in place to prevent the ingress of rain into the unit.

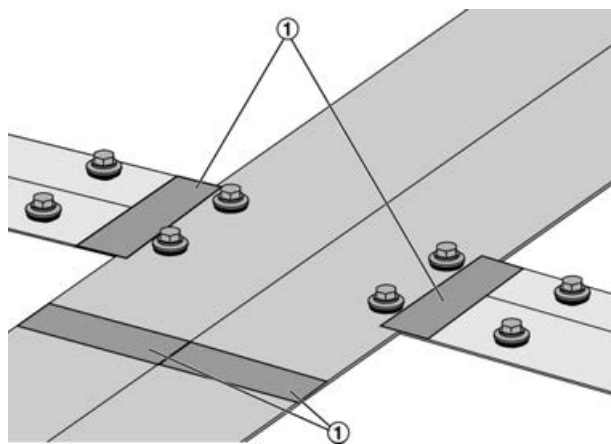

Fig. 22: Sealing the joints

- 2 ▶ Seal the joints (Fig. 22 /1) between the cover strips with the supplied adhesive strips (100 x 40 mm).

Make sure that all surfaces are clean, free from grease, and dry. Clean the surfaces, if necessary.

Stacked units (step design)

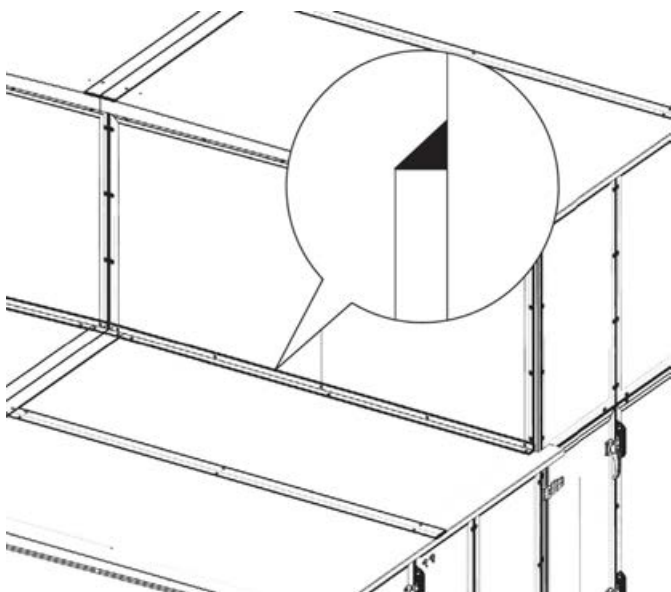

Fig. 23: Step design

- 3 ▶ Fix the connecting angle section for the roof segment with self-drilling screws and seal it with sealant.

Attaching the weather hood

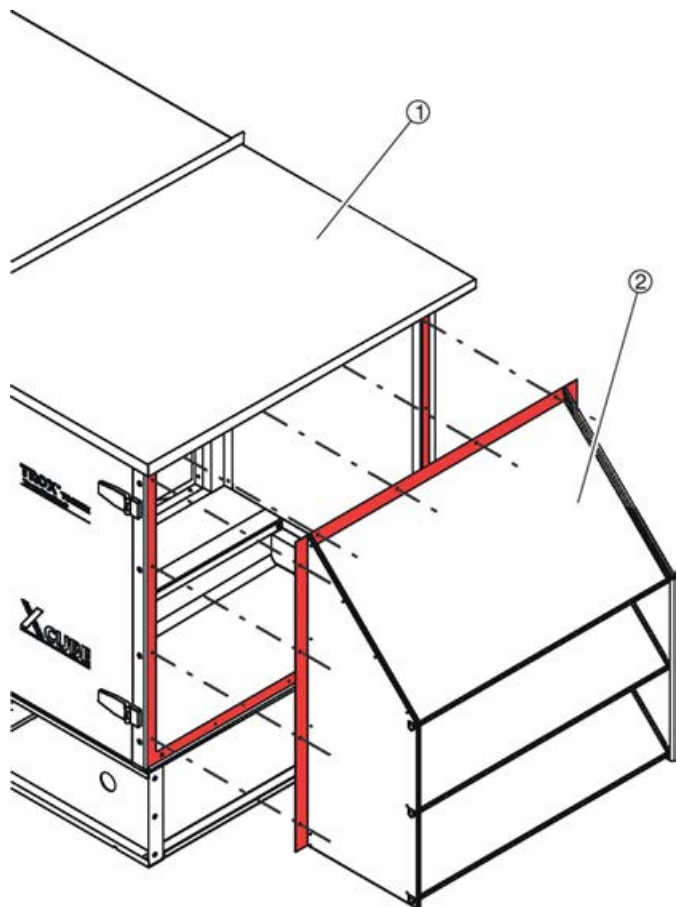

Fig. 24: Positioning the weather hood

- 1 ▶ Position the weather hood (Fig. 24 /2) precisely on the frame (Fig. 24 /1) such that the screw holes are in a line.

⚠ DANGER!

Risk of explosion!

The cover grille of the weather hood prevents foreign objects from being drawn into the unit. Using the weather hood without the cover grille may lead to an explosion.

Install the weather hood only with the cover grille attached.

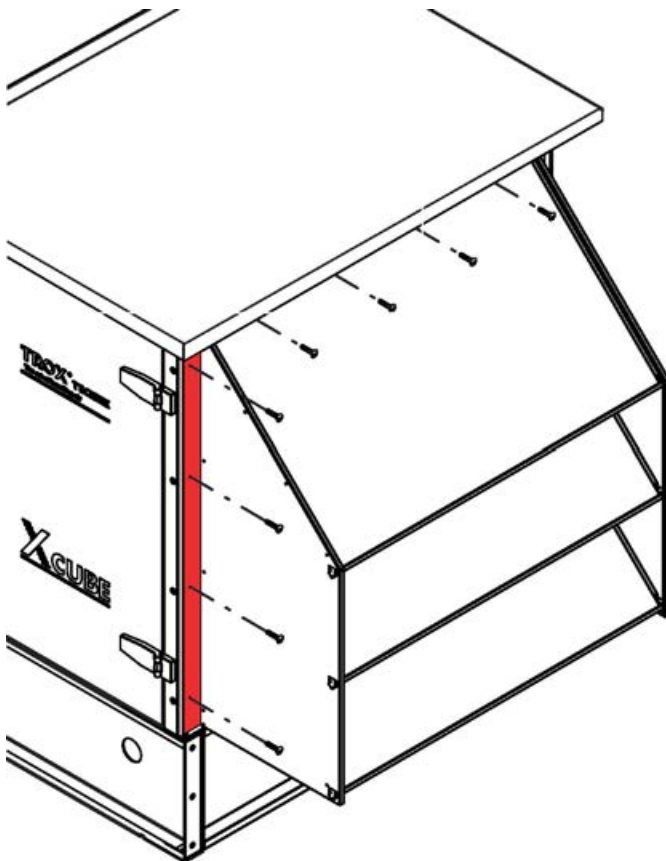

Fig. 25: Fixing the weather hood with screws

- 2 ▶ Screw the weather hood to the frame using M6x12 pan head screws.

1 ▶

! NOTICE!

Risk of water damage from incorrect assembly!

If units with an intermediate frame are installed outdoors, missing cover strips or incorrect assembly may lead to the ingress of water.

To prevent the ingress of water into the intermediate frame and hence into the unit, seal the intermediate frame with cover strips.

Fix the cover strips immediately after the assembly steps described above. If you do not fix the cover strips immediately, water may get into the unit and damage the components.

- 1 ▶ Each cover strip carries a code indicating its position (see table).

No. of the intermediate frame	Side code	Number (left → right)
01 ... 99	V Front = operating side	1.1 ... 9.1
	H Rear	
	L Left	
	R Right	

Fixing cover strips to the intermediate frame

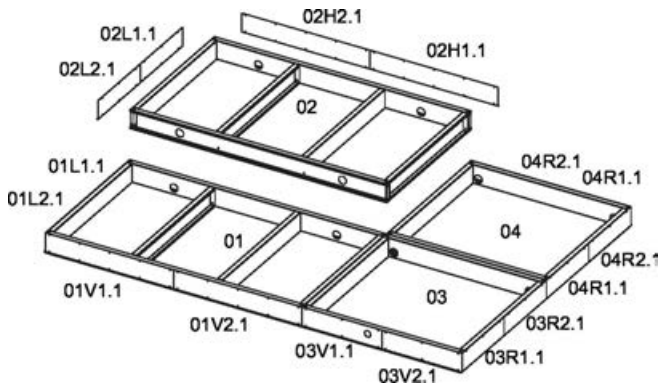

Fig. 26: Cover strip coding

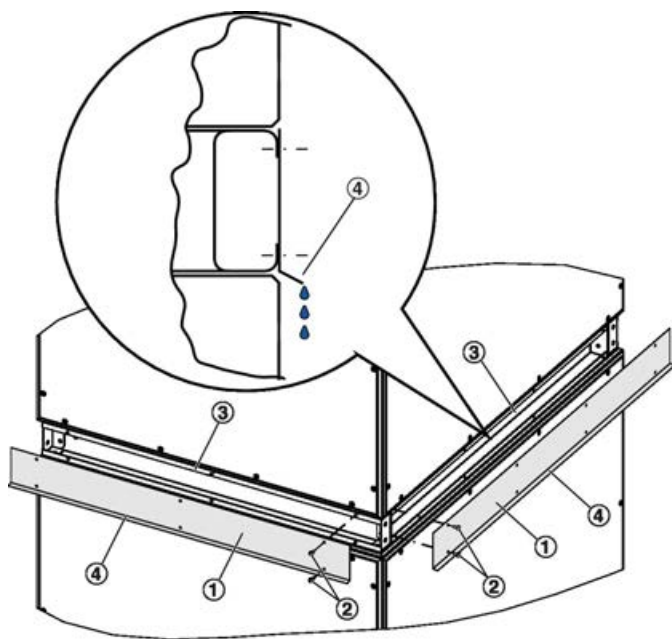

Fig. 27: Fixing cover strips

- 1 Cover strip for the intermediate frame
- 2 Thread forming pan head screws M6 x 12 (M852AC6)
- 3 Intermediate frame
- 4 Drip edge

- 2 ▶ Use pan head screws to attach the cover strips to the intermediate frame.

Important: Fix the cover strips in such a way that the drip edge is at the bottom. Ensure that the drip edge faces outwards.

⇒ This will prevent water from getting into outdoor units with an intermediate frame.

- 3 ▶ For outdoor units: Protect ducts (including spigots and connecting frames) against the effects of weather.

4.4.5 Installing accessories

Install any supplied accessories (e.g. pressure transducers) and any accessories provided by others (e.g. actuators, frost sensors) according to the manufacturers' instructions.

Installing ducts

Personnel:

- HVAC technician

Protective equipment:

- Industrial safety helmet
- Protective clothing
- Protective gloves
- Safety shoes

- 1 ▶ Ensure precise fit and avoid distortion when you connect the ducts.

Note: Any load on the noise insulating connector may impair the tight fit. Connect the duct in such a way that no loads are imposed on the connector; if necessary, slightly retighten the screws on the connector.

- 2 ▶ Insulate ducts (including flexible connectors and connecting frames).

5 Installation

5.1 Safety notes regarding installation

Incorrect installation

 **WARNING!**

Risk to life from incorrect installation!

Incorrect installation can lead to potentially fatal situations and cause considerable damage to property.

- Only a skilled qualified electrician must connect the power supply.
- Any other installation job has to be carried out by an HVAC technician.

Inspection access doors slamming shut

 **WARNING!**

Risk of crushing from doors slamming shut

Inspection access doors may slam shut by the wind or if someone pushes them inadvertently, resulting in serious injury to the head and limbs.

- Secure each inspection access door with a hold open device.
- Secure inspection access doors without a hold open device against closing by suitable means.
- Do not reach between the door and door frame.
- Wear protective gloves and a hard hat when you open an inspection access door.

Crushing hazard!

 **WARNING!**

Crushing hazard from movable parts!

There is an increased risk of crushing on casing units, doors, panels and components of the device.

- Never reach between moving parts.
- Be careful when carrying out any work.
- Wear protective gloves, safety shoes and a hard hat.

Hot surfaces

 **WARNING!**

Risk of injury from hot surfaces!

The surfaces of components can get very hot during operation. Skin contact with hot surfaces causes severe skin burns.

- Professionally insulate pipes that connect condensers or heating coils.

Interconnecting units and systems

 **WARNING!**

Risk of injury from interconnecting different units or systems!

Connecting an air handling unit to other units or systems (e.g. ductwork, pumps, refrigeration systems) can lead to dangerous situations and eventually cause serious or even fatal injuries.

- If you have to connect other units or systems to the air handling unit, connect them professionally.
- The system owner/HVAC contractor is responsible for the planning and installation of any additional safeguards.

Sharp edges, sharp corners and thin sheet metal parts

 **CAUTION!**

Danger of injury from sharp edges, sharp corners and thin sheet metal parts!

Sharp edges, sharp corners and thin sheet metal parts of the heat exchanger or of the cooling or heating coil may cause cuts or grazes.

- Be careful when working on these components.
- Wear protective gloves, safety shoes and a hard hat.

5.2 Before installation

Before installation

- Have all the applicable documents at hand,  'Other applicable documentation' on page 3
- Ensure that the installation requirements are met, see the order-specific data sheet for the air handling unit.
- Have all the required tools ready.

5.3 Sizing and connecting the condensate drain

Electric current

! WARNING!

Danger of death due to electric current!

If electrical components come into contact with water, e.g. from a leak, you could be seriously or even fatally injured. Water can also cause damage to the air handling unit.

- Lay drainage pipes in such a way that they cannot be accidentally damaged by mechanical impact or by heat.

Calculate height of drain trap

! NOTICE!

Leaks due to incorrect installation!

Connecting the condensate drain directly to the sewage system or using an unsuitable drain trap will result in air leaks in the air handling unit and is therefore not permitted.

- Use the AHU only with a suitable drain trap.
- Do not connect the drain trap directly to the sewage system; the drain trap must be able to drain freely.
- Use a different drain trap for each condensate drain. Do not connect condensate drains with each other.
- A gap must be left between the drain trap on the negative pressure side and the floor.

Calculate the height of a drain trap as shown below.

Formula symbol:

- P - Pressure inside the AHU [Pa]; always use a positive value for calculations. Take the final pressure loss (filter etc.) into consideration
- 1.5 - Safety factor to compensate for pressure fluctuations, e.g. due to fast-closing dampers (only for overpressure)
- GR - Base frame height [mm]
- R - Distance R [mm]; minimum distance between the centre of the condensate drain and floor on the overpressure side
- X + 60 - Distance X + 60 [mm]; minimum distance between the centre of the condensate drain and floor on the negative pressure side
- H - Distance H [mm]; minimum distance between lower edge of base frame and floor
- A - Distance A [mm]; distance between the lower edge of the base frame and the centre of the condensate drain; depending on the base frame height (GR) and unit width (B), see table
- B - Unit width (B)

Distance A

GR	Unit width	
	B ≤ 2448 [mm]	B > 2448 [mm]
	A	A
110	47	32
200	137	87
300	237	187

Negative pressure (extract air)

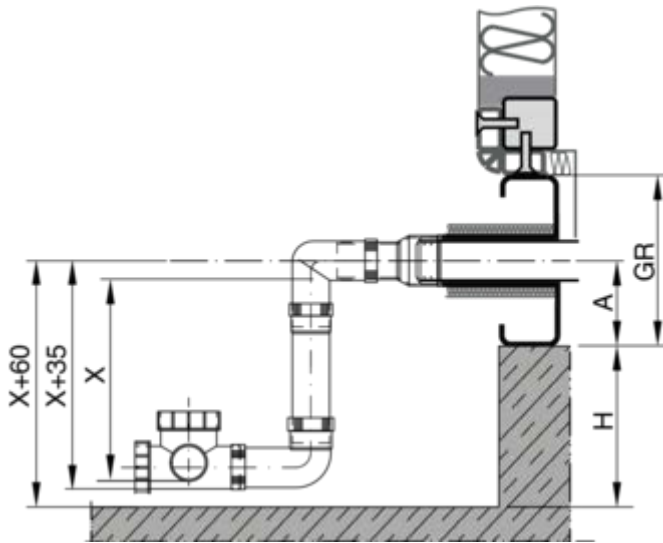

Fig. 28: Drain trap for negative pressure

Formulas for negative pressure (2900 Pa max.):

- $X = P / 10$
X+35 must be at least 140 mm
- $H = X + 60 - A$

Calculation example X-CUBE:

Given data:

- P - 1800 Pa
- GR - 110 mm
- B - 1500 mm
- A - 47 mm, see table

$X = 1800 \text{ Pa} / 10 = \underline{180 \text{ mm}}$

$H = 180 + 60 - 47 = \underline{193 \text{ mm}}$

Overpressure (supply air)

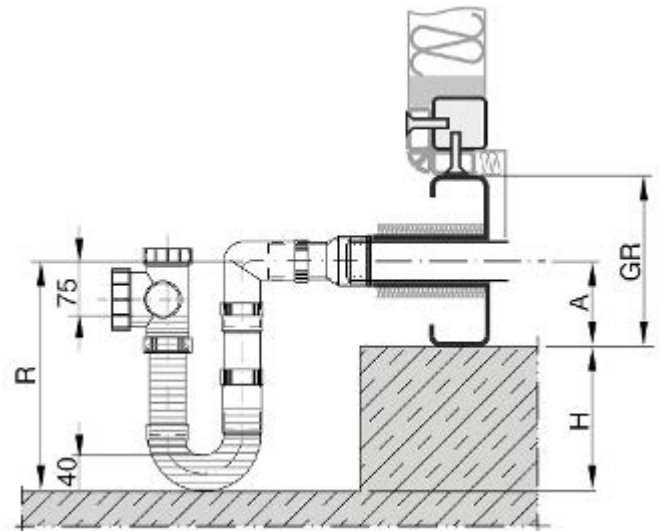

Fig. 29: Drain trap overpressure

Formulas for overpressure (1630 Pa max.):

- $R = P \times 1.5 / 10 + 115 (40 + 75)$
Always cut or extend dip tubes evenly. Do not cut a tube by more than 155 mm; R has to be at least 215 mm.
- $H = R - A$

Calculation example X-CUBE:

Given data:

- P - 1500 Pa
- GR - 200 mm
- B - 1500 mm
- A - 137 mm, see table

$R = 1500 \text{ Pa} \times 1.5 / 10 + 115 \text{ mm} = \underline{340 \text{ mm}}$

$H = 340 - 137 = \underline{203 \text{ mm}}$

Sizing and connecting the condensate drain

Connecting a drain trap

Personnel:

- HVAC technician

Protective equipment:

- Industrial safety helmet
- Protective clothing
- Protective gloves
- Safety shoes

! NOTICE!

Risk of damage to property due to improper connection!

Improper connection can damage the connection pipes and the drain trap, possibly leading to destruction.

- Make sure that the on-site connection does not transmit any forces or vibrations.
- For outdoor installation, the connection pipes must be frost-proof and UV-protected.

Connection dimensions for the drain trap, outer Ø of drainage pipe

Base frame	Intermediate floor tray
DN32	DN20
1 ¼"	¾"
42.3 mm	26.9 mm

- 1 ▶ Calculate the height of the drain trap as shown above.

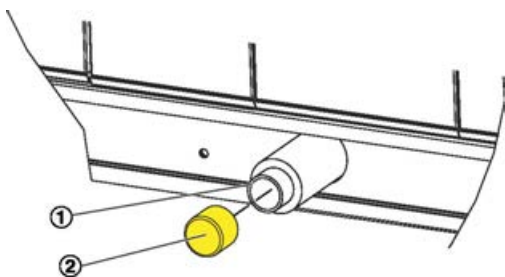

Fig. 30: Condensate drain

- 2 ▶ Remove the protective cap(s) (Fig. 30 /2) from the drain (Fig. 30 /1) of the condensate drip tray.

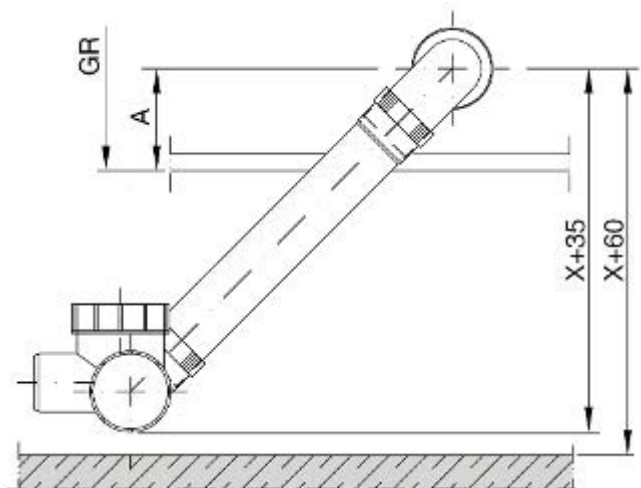

Fig. 31: Tilted position of negative pressure drain trap

- 3 ▶ Adjust the height of the drain tap based on the above calculation. Drain traps for negative pressure: Instead of shortening the dip tube, you can also install the drain trap in a sloping position.
- 4 ▶ Connect the drain traps to the condensate drains (Fig. 30 /1).

Do not connect the drain trap directly to the sewer; the drain trap must be able to drain freely. For hygienic reasons, the floor clearance must be maintained for drain traps for negative pressure.

Air handling units to be installed outdoors or in areas at risk of frost require frost protection for the drain trap; see the manufacturer's documentation.

! NOTICE!

UV protection

The drain traps optionally included in the scope of delivery of the AHU are not UV-resistant. The plastic may discolour under direct UV radiation. The siphons must be protected from UV radiation by structural measures (e.g. encasing).

5.4 ☒ Connecting the heating coil/cooling coil

Electric current

⚠ WARNING!

Danger of death due to electric current!

If electrical components come into contact with water or a water glycol mixture, e.g. from a leak, you could be seriously or even fatally injured. Water can also cause damage to the air handling unit.

- Lay connecting cables in such a way that they cannot be accidentally damaged by mechanical impact or by heat.
- Do not lay connecting cables across electrical components or switch cabinets as people may become entangled in them.

Connect heat exchangers in a counter flow arrangement unless a parallel flow arrangement has been specified by the manufacturer. Only a counter flow arrangement ensures that the calculated capacity is achieved.



If you have to attach brackets or fasteners to the AHU panels or frame, use only those specially approved for your AHU as otherwise there is a risk of leakages.

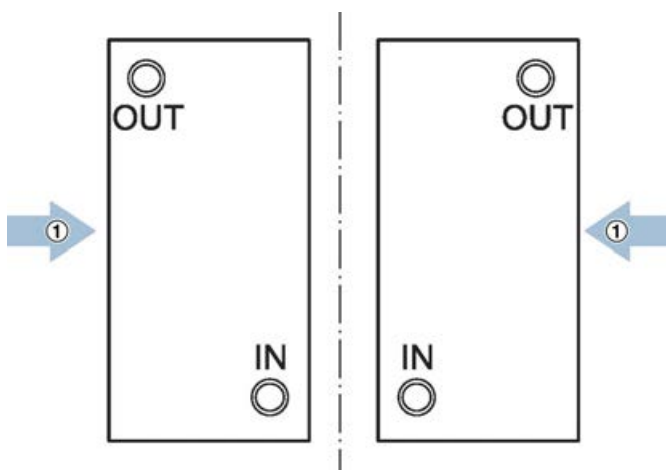

Fig. 32: Exemplary illustration of the heat exchanger connections in a counter flow arrangement

1 Airflow direction



Stickers on the connection side of the heat exchangers indicate the flow (Fig. 32 /IN) and return connections (Fig. 32 /OUT) for a counter flow arrangement.

For special heat exchanger constructions, however, the stickers may not show the correct type of connection. Heat exchangers must always be connected in a counter flow arrangement. If you have any questions regarding the connections, please contact the manufacturer.

An additional requirement for steam heat exchangers is that the return connection has to be at the bottom so that any condensate can be safely discharged. If you have any questions regarding the connections, please contact the manufacturer.

Connect slide-out heat exchangers and droplet eliminators with bends and detachable connections as otherwise you will not be able to withdraw them.

Personnel:

- HVAC technician

Protective equipment:

- Industrial safety helmet
- Hearing protection
- Protective clothing
- Protective gloves
- Safety shoes

! NOTICE!

Risk of damage to property from incorrect pipe connections!

Take care to connect the heat exchanger pipes correctly as otherwise the pipes may twist or become subject to adverse effects. This may eventually damage the heat exchanger beyond repair.

- Connect pipes in such a way that the heat exchanger is not affected by vibration and that no loads are imposed on it.
- If there is too much weight on a water pipe (by others), support the water pipe.
- Do not use the connection point of the heat exchanger as a fixing point for other parts.
- When you tighten thread connections, be sure to use a suitable tool (e.g. water pump pliers) to counter the tightening force as otherwise you may inadvertently damage the parts.
- If an AHU is installed outdoors, use suitable pipes and protect them from frost.
- Ensure that no air gets trapped in the pipes.

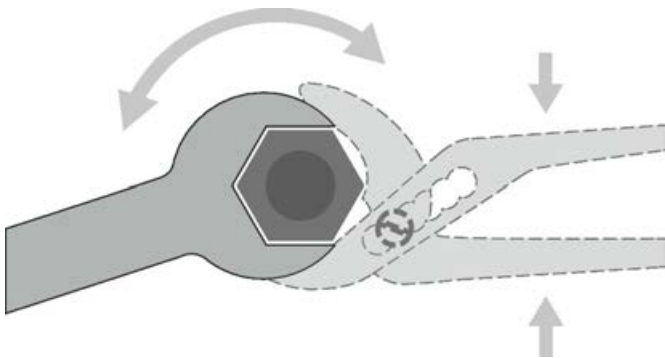

Fig. 33: Using water pump pliers to counter the tightening force

- ▶ Hold the threaded pipe tail of the heat exchanger with water pump pliers (Fig. 33 /2).
- ▶ Hold the threaded pipe tail with the pliers while you use a spanner (hexagonal profile, Fig. 33 /1) to connect the heat exchanger to the pipework (pipework by others).

Ventilation device

For optimum ventilation of the heat exchanger, we recommend that you install suitable air separators at the highest points of the system (e.g., above the air handling unit), which reduce the airflow velocity by increasing the cross section and can thus be ideally used for deaerating glycol systems.

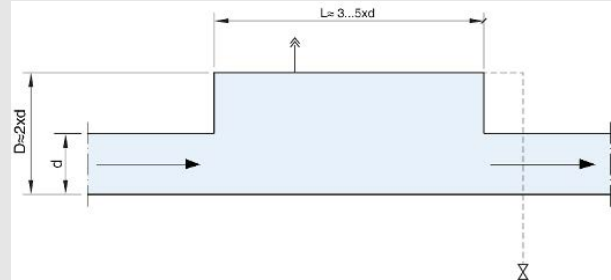

Fig. 34: Air separator with cross section enlargement

5.5 Connecting the steam heat exchanger

Hot surfaces

! WARNING!

Risk of injury from hot surfaces!

Steam heat exchangers are operated at temperatures of $>100\text{ }^{\circ}\text{C}$. Skin contact with the heat exchanger causes severe skin burns.

Before you start working on the heat exchanger, shut off the steam supply and make sure that all surfaces have cooled down to ambient temperature, e.g. with an infrared thermometer.

! DANGER!

Risk of injury due to escaping steam

If steam escapes due to a leak, immediately shut off the steam supply to the heat exchanger.

Before you start any repair work, completely drain the heat exchanger. This system contains steam at high pressure. If steam escapes due to a leak, it can cause severe scalds.

Connect steam heat exchangers in a counter flow arrangement unless a parallel flow arrangement has been specified by the manufacturer. Only a counter flow arrangement ensures that the calculated capacity is achieved.



If you have to attach brackets or fasteners to the AHU panels or frame, use only those specially approved for your AHU as otherwise there is a risk of leakages.

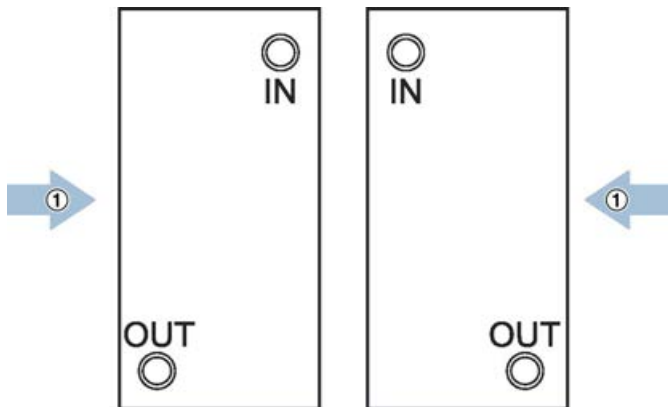

Fig. 35: Steam heat exchanger connections in a counter flow arrangement (example)

1 Airflow direction



Stickers on the connection side of the heat exchangers indicate the flow (Fig. 35 /IN) and return connections (Fig. 35 /OUT) for a counter flow arrangement.

For special heat exchanger constructions, however, the stickers may not show the correct type of connection. Heat exchangers must always be connected in a counter flow arrangement.

An additional requirement for steam heat exchangers is that the return connection has to be at the bottom so that any condensate can be safely discharged. If you have any questions regarding the connections, please contact the manufacturer.

Personnel:

- HVAC technician

Protective equipment:

- Industrial safety helmet
- Hearing protection
- Protective clothing
- Protective gloves
- Safety shoes

! NOTICE!

Risk of damage to property from incorrect pipe connections!

Take care to connect the heat exchanger pipes correctly as otherwise the pipes may twist or become subject to adverse effects. This may eventually damage the heat exchanger beyond repair.

- Connect pipes in such a way that the heat exchanger is not affected by vibration and that no loads are imposed on it.
- If there is too much weight on a water pipe (by others), support the water pipe.
- Do not use the connection point of the heat exchanger as a fixing point for other parts.
- If an AHU is installed outdoors, use suitable pipes and protect them from frost.

5.6 Connecting the run-around coil system

The proper connection of the pipework between the heat exchangers of the AHU and the hydraulic unit is carried out by the customer.

Connect heat exchangers in a counter flow arrangement as only a counter flow arrangement ensures that the calculated capacity is achieved. Use only suitable parts and materials and use only the marked connection points to connect the hydraulic unit.



If you have to attach brackets or fasteners to the AHU panels or frame, use only those specially approved for your AHU as otherwise there is a risk of leakages.

Setting up and connecting the hydraulic unit

Personnel:

- HVAC technician

Protective equipment:

- Industrial safety helmet
- Hearing protection
- Protective clothing
- Protective gloves
- Safety shoes
- Safety harness

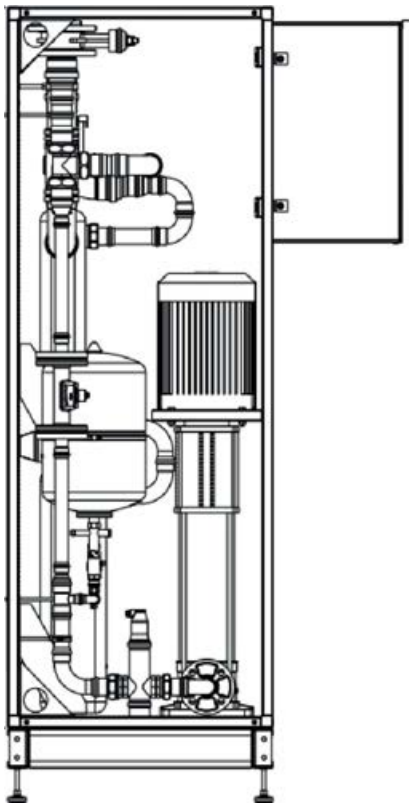

Fig. 36: Setting up the hydraulic unit

- ▶ Install the hydraulic unit so that it is parallel to the wall and floor.
- ▶ Alignment of the hydraulic unit
 - using leveling feet (optional) - Adjust the feet of the hydraulic unit so that it is level (use a 19 mm wrench).
 - without feet - Level out floor unevenness using materials provided by others, e.g. rubber or elastomer sheets.

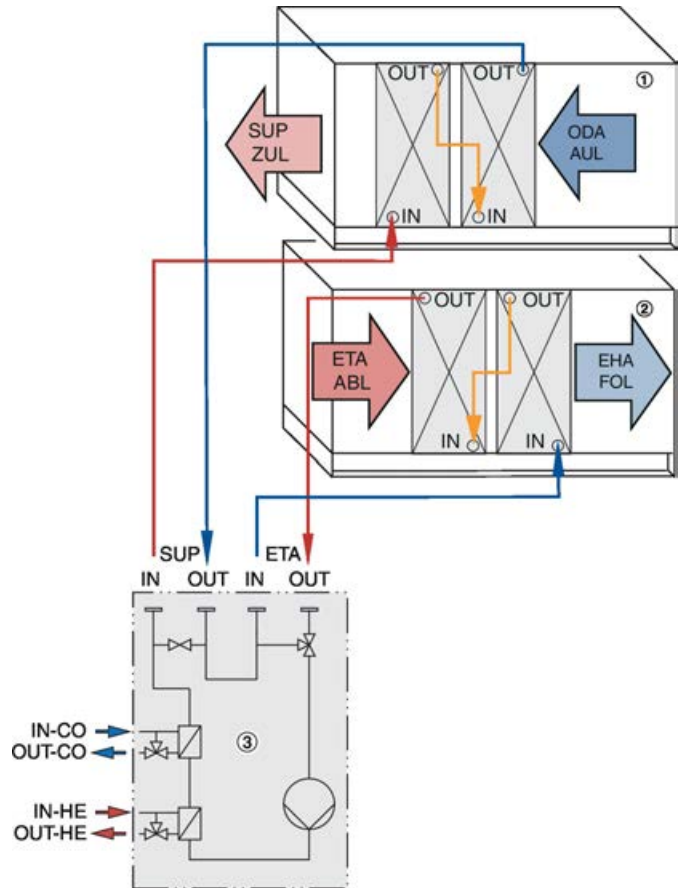

Fig. 37: Hydraulic system connection (example)

- ① Supply air unit
- ② Extract air unit
- ③ hydraulic unit
- IN Flow
- OUT Return

- ▶ Connect the heat exchanger with the hydraulic unit (Fig. 37).

If there are several heat exchangers in airflow direction, connect the pipes in series.

The position of the connection points is given in the order-specific approval drawing.

If you are in doubt about the position of any pipes to be connected, please get in touch with our Technical Service.

Heat exchanger connection

Connection on hydraulic unit	Heat exchanger Air handling unit	Description
IN-ETA	IN	Flow – extract air
OUT-ETA	OUT	Return – extract air

Connection on hydraulic unit	Heat exchanger Air handling unit	Description
IN-SUP	IN	Flow – supply air
OUT-SUP	OUT	Return – supply air

- 4 ▶ Run-around coil systems with external feeding: Make the required connections (Fig. 37).

Connections for external feeding

Connection on hydraulic unit	External feeding
IN-CO	Water flow – cooling
OUT-CO	Return – cooling
IN-HE	Water flow – heating
OUT-HE	Return – heating

Ventilation device

For optimum ventilation of the heat exchanger, we recommend that you install suitable air separators at the highest points of the system (e.g., above the air handling unit), which reduce the airflow velocity by increasing the cross section and can thus be ideally used for deaerating glycol systems.

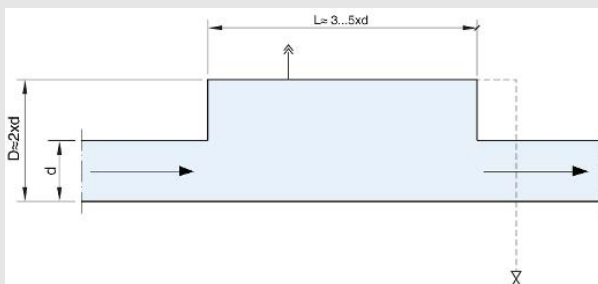

Fig. 38: Air separator with cross section enlargement

5.7 Wiring



Air handling units with X-CUBE Control are factory wired. The functions of all electronic parts, sensors, actuators, etc. are tested before shipment. If a unit has to be disassembled into AHU casing units for shipment or for moving to the final installation location, the cables are disconnected at suitable interfaces and either pushed back into the cable ducts or rolled up. The wiring is shown in the wiring diagram (see the switch cabinet).





Fig. 39: Example of separate cables

- 1 Pull wire for pulling in cables without separation
- 2 Bus line
- 3 Lighting
- 4 Anti-frost thermostat

Interface connections

Component	Connection	Job
X-CUBE Control <ul style="list-style-type: none"> ■ Bus Black cable with black M12 plug connection ■ Lighting Grey cable with black M12 plug connection 	 <p>M12 plug connections</p>	Plug the connectors together straight and tighten by hand. Then tighten the screw connections by 90° with the open-end spanners (securing against working loose).
X-CUBE Control sensors <ul style="list-style-type: none"> ■ Anti-frost thermostat Black cable with black 3-pin M8 plug connection ■ Duct smoke detector 1 Black cable with black 4-pin plug connection ■ Duct smoke detector 2 Black cable with red 4-pin plug connection 	 <p>M8 plug connector</p>	Plug M8 plug connections together straight.

Component	Connection	Job
Fans with < 13 A power consumption are pluggable.	 Plug the 5-pin power plug connectors	together straight and close the retainer (protection against working loose).
Fans > 13 A, double fans or fan arrays	No discontinuities, rolled-up cables	Route the cables through the intended cable routes and connect them to the switch cabinet according to the circuit diagram.
Rotary heat exchanger	 Plug the 3-pin power plug connectors	together straight and close the retainer (protection against working loose).
Shut-off dampers with spring return actuator torque > 20 Nm	No discontinuities, rolled-up cables	Route the cables through the intended cable routes and connect them to the switch cabinet according to the circuit diagram.



None of the other regulation and control components are designed to be pluggable. The rolled-up cables must be routed through the intended cable routes and connected to the switch cabinet according to the circuit diagram.

Connecting cables



Fig. 40: Connection of the cables

- 3 ▶ Then connect the separate cables according to the type of plug and the colours of the cable and plug, see 'Interface connections' on page 50. Connect only cables with the same code.
 - 4 ▶ When you push the AHU casing units together, feed the cables into the mesh cable trays and be careful to not damage any cables.
- 1 ▶ Place the AHU casing units as close together as possible so that you can connect the cables.
Note: If there is not much space, you can also connect the cables inside the AHU.
 - 2 ▶ First run the cables in sections through the AHU to the switch cabinet without discontinuities, see wiring diagram. Where cables have to be pulled in, e.g. behind heat recovery units, a pull wire is provided for pulling in the cable.

5.8 Connecting the AHU to the power supply

Electrical connection

DANGER!

Danger of death due to electric current!

Danger of electric shock! Do not touch any live components!

- Only a skilled qualified electrician must connect the power supply.
- For air handling units with integral controls use the circuit diagram in this manual,  'Other applicable documentation' on page 3
- Lay connecting cables in such a way that they cannot be accidentally damaged by mechanical impact or by heat.
- Bridge all non-conductive joints, such as connecting frames, flexible connectors and anti-vibration elements, with an equipotential bonding cable.
- Earth the air handling unit according to the state of the art.
- Secure all connections so that they cannot come loose.
- When you connect any electrical components, follow the manufacturers' specifications, the local regulations and codes of good practice (DIN/VDE), and the general recommendations for avoiding electromagnetic interference,
- If an AHU is installed outdoors, do not neglect the effects of weather on the unit (rain, snow, wind, sun etc.).



If you have to attach brackets or fasteners to the AHU panels or frame, use only those specially approved for your AHU as otherwise there is a risk of leakages. Avoid screw joints that pierce the outer shell of the unit; if you cannot avoid them, then at least seal them to prevent the ingress of water. The minimum protection level is IP 65.

1 ▶





Units with controls

The electrical circuit diagrams and terminal plans can be found in the circuit diagram included in the supply package.

- 1 ▶ Connect the electrical components, such as the electric air heater, electric motor, and actuator.
- 2 ▶ Include the air handling unit in the equipotential bonding arrangement.
- 3 ▶ Test protective conductors and insulation resistance to EN 60204 (VDE 0113). Take the appropriate safety precautions!

5.9 Integrating the air handling unit with the MCE

It is the duty of the system owner/HVAC contractor to integrate the air handling unit with the building services and to ensure conformity,  'System owner's obligations' on page 7 and  'Conformity assessment' on page 22 .

5.10 Connecting the measuring and control technology to the on-site PC or on-site network

Network or PC

Air handling units with optional integral controls are fitted with a touch panel on which the configuration and control parameters of the unit are displayed. This allows you to view all measured values and to enter setpoint values.

You can use a computer with a web browser instead of the touch panel to display the unit configuration. To do so, connect the air handling unit to a PC or integrate it with a network using the TCP/IP interfaces.



Further information on this can be found in the X-CUBE Control 2 operating instructions.

6 Initial commissioning

6.1 Safety notes regarding initial commissioning

Incorrect initial commissioning

WARNING!

Risk to life from incorrect initial commissioning!

Incorrect initial commissioning can lead to potentially fatal situations and cause considerable damage to property.

- Only skilled qualified electricians must work on the electrical system and on motors.
- All other initial commissioning steps must be carried out by an HVAC technician.

Inspection access doors on the discharge side

CAUTION!

Risk of injury from a strong airflow on the discharge side of fans!

When you open an inspection access door on the discharge side of the fan, the velocity and pressure of the airflow may cause the door to suddenly swing open until it is caught by the safety catch. You could be injured.

- Be careful when you open inspection access doors on the discharge side.

Sharp edges, sharp corners and thin sheet metal parts

CAUTION!

Danger of injury from sharp edges, sharp corners and thin sheet metal parts!

Sharp edges, sharp corners and thin sheet metal parts of the heat exchanger or of the cooling or heating coil may cause cuts or grazes.

- Be careful when working on these components.
- Wear protective gloves, safety shoes and a hard hat.

Crushing hazard!

WARNING!

Crushing hazard from movable parts!

There is an increased risk of crushing on casing units, doors, panels and components of the device.

- Never reach between moving parts.
- Be careful when carrying out any work.
- Wear protective gloves, safety shoes and a hard hat.

Inspection access doors slamming shut

WARNING!

Risk of crushing from doors slamming shut

Inspection access doors may slam shut by the wind or if someone pushes them inadvertently, resulting in serious injury to the head and limbs.

- Secure each inspection access door with a hold open device.
- Secure inspection access doors without a hold open device against closing by suitable means.
- Do not reach between the door and door frame.
- Wear protective gloves and a hard hat when you open an inspection access door.

6.2 Before initial commissioning

The air handling unit has been erected, assembled, and installed according to this manual.

Before initial commissioning, check the casing and the following parts for damage and correct position:

- Inspection access doors and openings
- Seals
- Handles and levers
- Connections
- Inspection window
- Panels

Before initial commissioning:

- Remove protective film, if any
- Check the unit for leakages
- Check inspection access doors and openings for function and tolerance
- Adjust the door closure, on page 55
- Adjust inspection access doors, on page 55
- Set up the centrifugal fan, 'Setting up the centrifugal fan' on page 56
- Insert the filters, 'Filters, inserting' on page 58
- Set up the heating coil/cooling coil, 'Commissioning the heating coil/cooling coil' on page 58

- Set up the multileaf dampers, ↪ 'Setting up multileaf dampers' on page 61
- Set up the sound attenuator, ↪ 'Setting up sound attenuators' on page 61
- Set up the rotary heat exchanger, ↪ 'Setting up the rotary heat exchanger' on page 62
- Set up the run around coil system, ↪ 'Commissioning the run around coil system' on page 60
- Set up the plate heat exchanger, ↪ 'Setting up the plate heat exchanger' on page 62
- Remove the protective caps from the condensate drains and connect the drain trap, ↪ Chapter 5.3 'Sizing and connecting the condensate drain' on page 42
- Clean the air handling unit, ↪ Operating manual, Maintenance.

6.3 Setting up AHU casing units

6.3.1 Inspection doors

The door leaf can be adjusted vertically with the slotted holes in the hinge block, and horizontally with the slotted holes in the hinge bracket.



The two-part hinge bracket simplifies mounting and removing inspection access doors. To remove an inspection access door, remove the hinge bracket screws.

Adjusting inspection access doors

Personnel:

- HVAC technician

Protective equipment:

- Industrial safety helmet
- Protective clothing
- Protective gloves
- Safety shoes

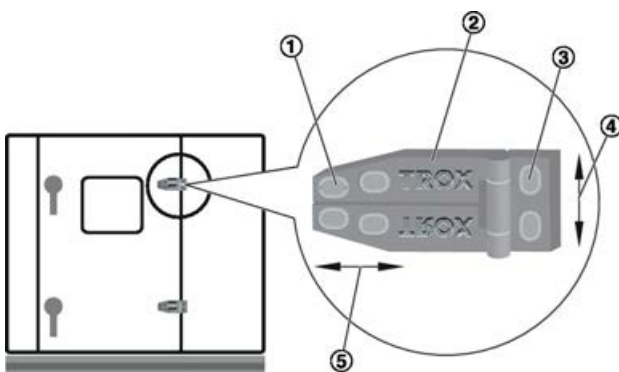

Fig. 41: Adjusting the door

- 1 ▶ Remove the hinge covers (Fig. 41 /1).

Adjusting the door horizontally

- 2 ▶ Loosen the screws of all hinge brackets (Fig. 41 /2) of a door.
- 3 ▶ Adjust the door horizontally (Fig. 41 /5).
- 4 ▶ Tighten the screws of the hinge brackets (Fig. 41 /2).

Adjusting the door vertically

- 5 ▶ Loosen the screws of all hinge blocks (Fig. 41 /3) on a door.
- 6 ▶ Adjust the door vertically (Fig. 41 /4).
- 7 ▶ Tighten the screws of the hinge blocks (Fig. 41 /3).

Adjusting the staple



Leaking inspection access doors

The contact pressure of the locking mechanism of the inspection access doors can be increased in the event of leaks using a compensating plate.

The compensating plate for this can be ordered from the Technical Service: article no.: A00000077107

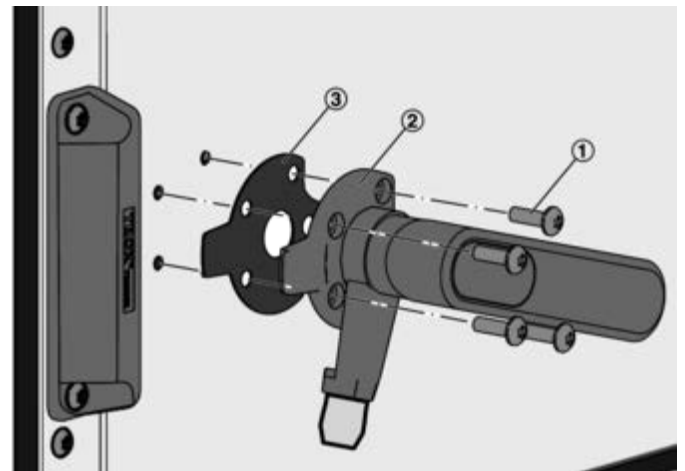

Fig. 42: Adjusting contact pressure of the inspection access door

- 8 ▶ Loosen screws (Fig. 42 /1) of the locking mechanism (Fig. 42 /2) and insert the compensating plate (Fig. 42 /3). Install by following these steps in reverse order and tighten the screws.

⇒ The inspection access doors have been adjusted.

6.3.2 Centrifugal fan

Operating point

The control system calculates the operating point and sets the default setpoint value for the fan.

During commissioning ensure that the following values are not exceeded:

- Maximum fan speed
- Minimum fan speed
- Motor rating

Do not change the clearance between the rotor and the bellmouth inlet.

Pressure measuring devices

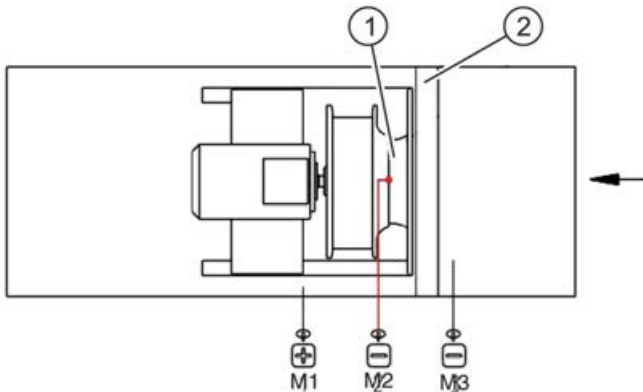

Fig. 43: Pressure measurement point

- 1 Bellmouth inlet
- 2 Partitioning panel
- M1 Pressure measurement point in the fan chamber
- M2 Pressure measurement point on the bellmouth inlet
- M3 Pressure measurement point in front of the partitioning panel

The fans may be factory fitted with pressure measuring devices (optional). The following pressure values are measured at the pressure measurement point (Fig. 43 /M2) in the bellmouth inlet (Fig. 43 /1), the pressure measurement point (Fig. 43 /M1) in the fan chamber, and the pressure measurement point (Fig. 43 /M3) in front of the partitioning panel.

Pressure	Determined from
Static fan pressure increase	Differential pressure between M1 and M3
Effective pressure (Δp_w) of the fan	The differential pressure between M2 and M3 is used to calculate the volume flow rate.

Calculation of the volume flow rate

$$\dot{V} = k \times \sqrt{\Delta p_w}$$

The K value is given on the TROX fan rating plate on the air handling unit.

This value may be different from the K value on the rating plate from the fan manufacturer (which should not be used for the calculation).

Setting up the centrifugal fan

WARNING!

Risk of injury from the incorrect handling and operation of fans!

Incorrect handling, e.g. reaching into rotating parts, can lead to serious injuries.

- Do not reach into the moving fan or tamper with it.
- The fan does not stop immediately! Check that no parts are moving before you open an inspection access door.
- Do not put a damaged or defective fan into operation.
- Do not exceed a fan's maximum capacity, e.g. when there are strong vibrations or against a closed multileaf damper.
- Switch off the AHU before you start working on movable fan parts and secure it against accidentally being switched on again. Wait until all parts have come to a standstill.

WARNING!

Risk of fire from damaged fan parts!

Grinding rotors or overheating bearings can cause a fire and eventually serious or even fatal injuries.

- Do not put a damaged or defective fan into operation.
- The power consumption must not exceed the specified nominal current.
- Make sure that the maximum motor speed is not exceeded.

Personnel:

- Skilled qualified electrician

Protective equipment:

- Protective clothing
- Hearing protection
- Industrial safety helmet
- Protective gloves
- Safety shoes

- 1 ▶ Remove the red transport protection devices from the fan.
- 2 ▶ Check the fan for shipping damage, imbalance, corrosion and contamination.
- 3 ▶ Check ducts and fan for foreign matter.

- 4 ▶ Turn the rotor manually to check that it moves freely.



The clearance between the rotor and the bellmouth inlet may have changed due to vibrations during transport. Check before commissioning that the distance between the inner edge of the rotor and the outer surface of the bellmouth inlet is the same everywhere.

- 5 ▶ Tighten all fixing screws.
- 6 ▶ Check the bearings and relubricate them if necessary.
- 7 ▶ Make sure that the multileaf dampers are open, ↪ 'Setting up multileaf dampers' on page 61 .
- 8 ▶ Check the direction of rotation of the fan by switching on the motor for a moment.



Nominal motor power of 3 kW and higher: star delta start.



In units with a fan with asynchronous motor, the arrow indicating the direction of rotation can be found on the fan casing.

In units with an EC fan, the fan will automatically start in the correct direction of rotation.

- 9 ▶ You can change the direction of rotation by swapping the terminal connections.
- 10 ▶ Ensure that the unit has been correctly earthed.
- 11 ▶ Close all inspection access doors on the air handling unit ↪ Operating manual.
- 12 ▶ Measure the current consumption with the inspection access doors closed and compare it with the nominal current.



If the current consumption exceeds the value given on the motor rating plate, switch off the fan immediately.

- 13 ▶ Check the function of the anti-vibration elements.
- 14 ▶ Moving towards all possible operating points, check whether the fan is running smoothly and with minimal vibration only.

! NOTICE!

Material damage due to strong vibrations or resonances!

Vibrations or resonances can cause considerable damage to the fan.

Therefore, a vibration check of the fans must be carried out before commissioning in order to exclude vibrations caused by unsteady running (imbalance), e.g., due to damage from transport or installation. We recommend a vibration test of the fans for mechanical vibrations in accordance with ISO 14694.

Be sure to take adequate precautions in the process:

- In the event of unusual oscillations, vibrations, temperatures or bearing noises, switch off the AHU immediately and inform ↪ *TROX Technical Service* .
- Check the system for resonances. If unacceptably high vibrations occur at the fan at an operating point, the system must not be put into operation or the critical speed range must be blocked. ↪ Fan manufacturer's documentation.
- For fans with frequency inverter (FI), also observe the fan manufacturer's documentation for commissioning!

- 15 ▶ Measure the volume flow rate.

⇒ The centrifugal fan has been set up.

6.3.3 Filter unit

Filters, inserting

Personnel:

- HVAC technician

Protective equipment:

- Industrial safety helmet
- Protective clothing
- Protective gloves
- Safety shoes



- Filters may become contaminated due to construction work in the building which is why we recommend that you replace all filters after the construction phase and initial commissioning.
- Do not operate the air handling unit without a filter.
- One spare filter element should always be available so that the air handling unit does not have to be switched off. Store filters in a dry place, free from dust, so that they will not be contaminated or damaged. Do not use filters beyond the use before date. Original TROX filters carry a sticker on the frame with both the use before date and information on how to order replacements.

- 1 ▶ Ensure that the filters are intact.



Defective filters may become torn while in use and will then no longer be effective.

- 2 ▶ Remove any dust from all parts that are in upstream direction before the filter.



Clean the air handling unit and ventilation ducts before you install any filter of class F9 or higher.

- 3 ▶ Fit filters into the installation subframe and fix them with the clamping elements. Make sure that they are tightly seated.

⇒ The filter has been set up.

6.3.4 Heating coil/cooling coil

Glycol-containing media



WARNING!

Health risk from media that contain glycol!

The media in the heating coil, cooling coil and run-around coil system contain glycol, which can cause serious health damage in the event of physical contact, swallowing or inhalation of aerosols.

- Avoid contact with media that contain glycol.
- Work must only be carried out by qualified refrigeration technicians, HVAC technicians or the TROX Technical Service .
- Do not eat, drink or smoke while handling media that contain glycol.
- Wash hands before breaks and at the end of work.
- After contact with glycol-containing media, follow the first aid measures on the safety data sheet provided by the media manufacturer.
- When handling glycol-containing media, wear the personal protective equipment specified in the safety data sheet provided by the media manufacturer.

Commissioning the heating coil/cooling coil

Personnel:

- HVAC technician

Protective equipment:

- Industrial safety helmet
- Protective clothing
- Protective gloves
- Safety shoes



Ensure that the maximum pressure values given in the technical data are not exceeded.

Use appropriate measures to protect the water system from frost. Frost protection can be achieved with a water glycol mixture or with a special anti-frost thermostat.



Optimum ventilation

For the best possible ventilation, we recommend installing on-site ventilation equipment at the highest point of the system; see on page 45 .

- 1 ▶ Ensure that the flow and return connections are correct.
- 2 ▶ Check that fittings are correctly installed.

- 3 ▶ Flush the system to remove any contamination.
- 4 ▶ Open vents (unless automatic vents have been installed).



Evaporators: As soon as you open the heat exchanger connection, the contained nitrogen shield gas content should escape with a hissing sound. The absence of this sound indicates a leak which has to be fixed before commissioning.

- 5 ▶



For glycol water mixtures we recommend ready-to-use formulations. See the order-specific air handling unit data sheet from TROX for the mixing ratio.

The correct mixing ratio is important:

- Too much glycol will impair performance
- Too little glycol may lead to frost damage

.

Only use one of the following glycols for the air handling unit:

- Propylene glycol
- Ethylene glycol

- 5 ▶ Slowly pour the heat transfer fluid into the heat exchanger at the lowest point in the system. As you fill the system, check that all external and internal screw joints and connections are tight.
- 6 ▶ Vent the heating coil/cooling by opening the upper spigot and the bleed screw.



If the air heater is not properly vented, air bubbles may form and impair the performance.

- 7 ▶ Close any vents.
- 8 ▶ Clean the condensate drip tray and drain.
- 9 ▶ Set up the droplet eliminator.
- 10 ▶ Fill the drain trap with water.

! NOTICE!

Risk of damage to property!

- When you tighten thread connections, be sure to use a suitable tool (e.g. water pump pliers) to counter the tightening force as otherwise you may inadvertently damage the parts.

- 11 ▶ Check the flange screw joints and tighten them if necessary.

⇒ The heating coil/cooling coil has been set up.

6.3.5 Electric air heater

Personnel:

- Skilled qualified electrician

Protective equipment:

- Protective clothing
- Hearing protection
- Industrial safety helmet
- Protective gloves
- Safety shoes

In air handling units with X-CUBE Control (controls), both the temperature monitoring and the safety temperature limiter operate independently of one another to ensure that no inadmissible overheating occurs at the electric air heater.

For air handling units with on-site controls, on-site measures must be taken to prevent impermissible temperature excesses. The manufacturer documentation must be observed for this purpose, see attachment.



CAUTION!

Protection against overheating

The electric air heater must be installed so that the heating elements cannot start up before the intended air volume flow is reached. The electric air heater must be put out of operation as soon as the volume flow rate is reduced to a level that is not permitted or the fan is switched off.

To prevent a temperature excess that is not permitted, two temperature-limiting devices must be installed in the air handling unit independently of each other (temperature monitor and safety temperature limiter).

6.3.6 ☒ Run-around coil system

The run around coil system must only be put into operation after the entire system has been professionally connected and checked (both hydraulic and electrical systems). These checks have to be recorded, and the results have to be available at the time of commissioning.

Glycol-containing media

WARNING!

Health risk from media that contain glycol!

The media in the heating coil, cooling coil and run-around coil system contain glycol, which can cause serious health damage in the event of physical contact, swallowing or inhalation of aerosols.

- Avoid contact with media that contain glycol.
- Work must only be carried out by qualified refrigeration technicians, HVAC technicians or the TROX Technical Service .
- Do not eat, drink or smoke while handling media that contain glycol.
- Wash hands before breaks and at the end of work.
- After contact with glycol-containing media, follow the first aid measures on the safety data sheet provided by the media manufacturer.
- When handling glycol-containing media, wear the personal protective equipment specified in the safety data sheet provided by the media manufacturer.

Commissioning the run around coil system

Personnel:

- HVAC technician

Protective equipment:

- Industrial safety helmet
- Protective clothing
- Protective gloves
- Safety shoes



Ensure that the maximum pressure values given in the technical data are not exceeded.

Use appropriate measures to protect the water system from frost. Frost protection can be achieved with a water glycol mixture or with a special anti-frost thermostat.



Optimum ventilation

For the best possible ventilation, we recommend the installation of ventilation equipment by others at the highest point of the system, see 'Setting up and connecting the hydraulic unit' on page 48 .

- 1 ▶ Ensure that the flow and return connections are correct.
- 2 ▶ Check that fittings are correctly installed.
- 3 ▶ Flush the system to remove any contamination.

- 4 ▶ Check the run around coil system for leaks.
- 5 ▶ Open vents (unless automatic vents are installed).
- 6 ▶



For glycol water mixtures we recommend ready-to-use formulations. See the order-specific air handling unit data sheet from TROX for the mixing ratio.

The correct mixing ratio is important:

- Too much glycol will impair performance
- Too little glycol may lead to frost damage

Only use one of the following glycols for the air handling unit:

- Propylene glycol
- Ethylene glycol

- 6 ▶ Slowly pour the heat transfer fluid into the heat exchanger at the lowest point in the system. As you fill the system, check that all external and internal screw joints and connections are tight.
- 7 ▶ Vent the heating coil/cooling by opening the upper spigot and the bleed screw.



If the air heater is not properly vented, air bubbles may form and impair the performance.

- 8 ▶ Close any vents.
- 9 ▶ Clean the condensate drip tray and drain.
- 10 ▶ Set up the droplet eliminator.
- 11 ▶ Fill the drain trap with water.

NOTICE!

Risk of damage to property!

- When you tighten thread connections, be sure to use a suitable tool (e.g. water pump pliers) to counter the tightening force as otherwise you may inadvertently damage the parts.

- 12 ▶ Check the flange screw joints and tighten them if necessary.
 - ⇒ The run around coil system has been set up.

6.3.7 Multileaf dampers

Movable parts of multileaf dampers



WARNING!

Crushing hazard from movable parts!

Closing multileaf dampers may crush your hands and arms.

- Do not reach between the damper blades.
- Prevent access to crush points: Either install dampers on ducts or use fixed guards.
- Before you open an inspection access door, switch off the air handling unit and secure it against being switched on accidentally.

Setting up multileaf dampers

Set the AHU control system in such a way that the fan does not operate against a closed damper.

TROX does not accept liability for damages resulting from incorrect operation. To prevent damage due to pressure surges from fire dampers, pressure relief dampers should be installed.



TROX cannot guarantee leak-free dampers if the actuators are provided and installed by others.

Powered dampers

Personnel:

- HVAC technician

Protective equipment:

- Industrial safety helmet
- Protective clothing
- Protective gloves
- Safety shoes

- 1 ▶ Adjust the linkage in such a way that the angle of rotation is 90° and the dampers close completely.
 - ⇒ Powered multileaf dampers have been set up.

Coupled dampers (for plate heat exchanger)

Personnel:

- HVAC technician

Protective equipment:

- Industrial safety helmet
- Protective clothing
- Protective gloves
- Safety shoes

- 1 ▶ Check that the friction locking of the linkage is correct.

- 2 ▶ Check the direction of rotation direction and ensure that the blades fully open and close.
- 3 ▶ Check that all screw joints and connections are tight.
 - ⇒ The coupled multileaf dampers have been set up.

6.3.8 Sound attenuator

Setting up sound attenuators

The splitter filling is made of non-combustible absorption material to DIN 4102.

Personnel:

- HVAC technician

Protective equipment:

- Industrial safety helmet
- Protective clothing
- Protective gloves
- Safety shoes

- 1 ▶ Check splitters for damage and contamination.
 - ⇒ The sound attenuator has been set up.

6.3.9 Rotary heat exchanger



WARNING!

Risk of injury from rotating parts!

Incorrect handling, e.g. reaching into rotating parts, can lead to serious injuries.

Never reach into or tamper with the storage mass

- Switch off the system before you start working on movable parts of the rotary heat exchanger and secure it against accidentally being switched on again. Wait until all parts have come to a standstill.
- Do not put a damaged or defective rotary heat exchanger into operation.

Adjusting the rotary heat exchanger

The storage mass of the rotary heat exchanger is factory set. You may have to adjust the storage mass to the actual installation conditions, see the manufacturer's documentation.

Setting up the rotary heat exchanger

Personnel:

- HVAC technician

Protective equipment:

- Protective clothing
- Hearing protection
- Industrial safety helmet
- Protective gloves
- Safety shoes



Ensure that permitted values for parameters such as temperatures or differential pressure are not exceeded.

- 1 ▶ Check whether the system has been correctly installed.
- 2 ▶ Inspect the rotary heat exchanger for foreign matter.
- 3 ▶ Check rotor for free running according to manufacturer's documentation!
- 4 ▶ Check the rotation direction of the rotor and change it on the motor controller, if necessary. Follow the manufacturer's operating instructions.



If the heat exchanger includes a purge sector, the rotating storage mass passes from the extract air via the purge sector to the supply air.

- 5 ▶ Check that the control module functions correctly.
- 6 ▶ Check the drive belt tension.
- 7 ▶ Set up the actuator according to the manufacturer's documentation.
- 8 ▶ Check the seals for contact pressure according to the manufacturer's documentation and adjust if necessary.
⇒ The rotary heat exchanger has been set up.

Setting up the drive equipment

Personnel:

- Skilled qualified electrician

Protective equipment:

- Protective clothing
- Hearing protection
- Industrial safety helmet
- Protective gloves
- Safety shoes

We recommend that you check the tension of the drive belt regularly during the first 400 hours of operation.

- 1 ▶ Open the inspection access panel on the indicated corner of the rotor casing.
- 2 ▶ Check whether the drive belt has sufficient tension; if necessary, shorten the belt as follows:

Shortening the drive belt

- 3 ▶ Open the lock.
- 4 ▶ Shorten the belt as required.
- 5 ▶ Close the lock.
- 6 ▶ Close the inspection access panel.

Checking the motor

- 7 ▶ Ensure that the motor is securely fixed.
⇒ The drive equipment has been set up.

6.3.10 Plate heat exchanger

Setting up the plate heat exchanger

Personnel:

- HVAC technician

Protective equipment:

- Industrial safety helmet
- Protective clothing
- Protective gloves
- Safety shoes

NOTICE!

Risk of damage to property from extreme pressure drop!

An extreme pressure drop between the supply air and extract air flows can damage the heat exchanger.

- Ensure that the maximum differential pressure (approx. 1000 Pa, depending on unit design) is not exceeded.
- Check differential pressure on pressure monitors according to the specified intervals.

- 1 ▶ Check and, if necessary, clean the plate heat exchanger to remove foreign matter and contamination.
⇒ The plate heat exchanger has been set up.

6.3.11  **Humidifier**

Setting up the humidifier

Personnel:

- HVAC technician

Protective equipment:

- Protective clothing
- Industrial safety helmet
- Hearing protection
- Protective gloves
- Safety shoes



The position of the droplet eliminator cassettes may have changed due to vibrations during transport.

If there are gaps between the cassettes, mist from the humidifier module could get into the unit and accumulate to water.



- 1 ▶ Check the position of each droplet eliminator cassette of the humidifier. If there is a gap between any two cassettes, adjust the position of the cassettes.

The droplet eliminator cassettes are arranged in two rows, staggered one behind the other, so the gap dimensions on the upstream and downstream sides of the humidifier must be checked. It may be necessary to disconnect ducts to get access to the cassettes.

- 2 ▶

! NOTICE!

Be sure to comply with the humidifier manufacturer's instructions for commissioning.

- 3 ▶ Check water connections and water pipes installed in the air handling unit for leaks. Retighten the screw connections in case of leaks.

⇒ The humidifier is now ready for use.

6.3.12 Electrical system

Personnel:

- Skilled qualified electrician

Protective equipment:

- Protective clothing
- Hearing protection
- Industrial safety helmet
- Protective gloves
- Safety shoes

Before commissioning, the electrical system has to be tested according to IEC 60364-6 (VDE 0100-600). As part of this, all on-site electrical connections must be checked for secure fitting (by the client) This applies in particular to motor terminal boards, fuses, local isolators etc.

6.4 Starting the air handling unit

6.4.1 Before you start the AHU

Before you switch on the air handling unit, make sure that the following requirements have been met:

- Has the air handling unit been checked for damage?
- Have the transport protection devices been removed?
- Have the filters been inserted?
- Have all inspection access doors and openings been adjusted and closed?
- Have all ducts in the AHU been connected?
- Have the AHU and the connected ducts been tested for any leaks?
- Has the interior of the air handling unit been cleaned?
- Have all drain traps been filled with water?
- Does the supply of power and of operating fluids meet all requirements?
- Has all the safety equipment been installed? Does it work properly?
- Have all the electrical connections been made and secured according to the relevant national standards?
- Has the heating coil/cooling coil been correctly connected and filled?
- Has the centrifugal fan been set up?
- Have the multileaf dampers been set up?
- Has the sound attenuator been set up?
- Has the rotary heat exchanger been set up?
- Has the run around coil system been correctly filled?
- Has the plate heat exchanger been set up?
- Are the environmental conditions for correct use being met?

6.4.2 Switching on

Switching on the AHU by qualified personnel

Only specially trained individuals may start the AHU.

Follow the start-up instructions in the operating manual for the AHU.

For units supplied without TROX measurement, control and regulation technology (MCR), follow the instructions provided by the MCR supplier.

7 Removal and disposal

7.1 Safety notes regarding disassembly and disposal

Incorrect disassembly

DANGER!

Risk to life from incorrect assembly and disassembly!

Incorrect assembly or disassembly can result in risks to life and limb and in environmental hazards.

- Before you start disassembly, professionally disconnect all electrical cables.
 - Only a skilled qualified electrician must disconnect the power supply.
 - Ensure that no voltage is present.
- Before you start disassembly, correctly drain all operating fluids.
 - Disconnect operating fluid pipes and hoses.
 - Ensure that operating fluids are disposed of correctly.
- If you have any questions regarding disassembly, refer to the assembly instructions in this manual. Pay attention to the component manufacturers' documentation.
- Only trained specialist personnel must remove any components.
- If necessary, use additional personal protective equipment for outdoor installations, e.g. a safety harness.

Improper transport equipment

WARNING!

Risk to life from using improper transport equipment!

If packages are lifted without adequate transport equipment and if they are not properly secured, they may fall off and lead to fatal injuries.

- Move components only in the position in which they are to be installed.
- Stand clear of suspended loads.
- Do not move additional loads on top of a package.
- Use only the intended lashing points.
- Make sure that no load is imposed on pipes, ducts or cables.
- Use only approved lifting gear and slings that are suitable and sufficient for the load to be carried.
- Do not tie ropes and chains or make knots or place them on sharp edges.
- Use lifting equipment only to lift packages or units, not to push or pull them.
- Ensure that ropes, belts and chains do not twist.
- Ensure that transport equipment has been correctly assembled, fastened and secured before you use it to lift anything.
- Secure all doors, dampers and panels.
- Move packages without any jerky movements and put them down when you leave your workplace.
- Lifting eyes are designed for one-time use only and not for permanently suspending loads.
- Transport tubes are designed for one-time use only and not for permanently suspending loads.

 2.4 'Dangers when handling the AHU' on page 8

Unbalanced loads and centre of gravity

WARNING!

Risk of injury from falling or toppling loads!

Loads may be unbalanced, i.e. the centre of gravity may not be obvious. If the load is not properly attached to the lifting equipment, it may topple and fall. Falling or toppling loads can cause serious injuries.

- When you use a crane to move loads, ensure that the centre of gravity of the load is directly beneath the crane hook.
- Lift any load carefully and keep an eye on it to see whether it will stay in place. If required, change the lashing point(s).

Crushing hazard!

WARNING!

Crushing hazard from movable parts!

There is an increased risk of crushing on casing units, doors, panels and components of the device.

- Never reach between moving parts.
- Be careful when carrying out any work.
- Wear protective gloves, safety shoes and a hard hat.

Inspection access doors slamming shut

WARNING!

Risk of crushing from doors slamming shut

Inspection access doors may slam shut by the wind or if someone pushes them inadvertently, resulting in serious injury to the head and limbs.

- Secure each inspection access door with a hold open device.
- Secure inspection access doors without a hold open device against closing by suitable means.
- Do not reach between the door and door frame.
- Wear protective gloves and a hard hat when you open an inspection access door.

Sharp edges, sharp corners and thin sheet metal parts

CAUTION!

Danger of injury from sharp edges, sharp corners and thin sheet metal parts!

Sharp edges, sharp corners and thin sheet metal parts of the heat exchanger or of the cooling or heating coil may cause cuts or grazes.

- Be careful when working on these components.
- Wear protective gloves, safety shoes and a hard hat.

ENVIRONMENT!

Risk of harm to the environment due to incorrect disposal of goods and packaging!

Incorrect disposal can harm the environment.

- Have electronic waste, electronic components and operating fluids (refrigerant, compressor oil, lubricants etc.) disposed of by an approved specialist disposal company.

7.2 Disassembly

Personnel:

- HVAC technician
- Skilled qualified electrician

Protective equipment:

- Industrial safety helmet
- Protective clothing
- Hearing protection
- Protective gloves
- Safety shoes

- 1 ▶ Disconnect electrical cables.
Ensure that no voltage is present.
- 2 ▶ Remove all operating fluids.
Properly dispose of all operating fluids.
- 3 ▶ Disconnect operating fluid pipes and hoses.
- 4 ▶ Open all module connectors and base frame connectors.
- 5 ▶ Remove the various unit components.
Use suitable transport equipment to move unit components away from the site.

7.3 Disposal

If no return or disposal agreement is in place, any disassembled components should be disposed of by an approved specialist disposal company.

Components that are no longer required should be recycled:

- Scrap the metals.
- Take plastic parts to be recycled.
- Dispose of other components and waste in a suitable manner, i.e. depending on their material properties.

Electrical and electronic components

Electrical and electronic components can contain materials and substances that are hazardous to health and the environment and which must not get into household and commercial waste.

As electrical and electronic components may also contain recyclables (e.g. precious metals), they must be provided for recycling or disposal by a specialist disposal company.

Chemicals

Chemicals (solvents, cleaning agents, operating fluids, etc.) affect the air, soil, water, and human health in various ways. In some cases, valuable substances can be extracted from them.

Chemicals must therefore not get into the air, soil, sewerage system, surface water or groundwater.

Commission an approved specialist disposal company to recover or dispose of chemicals.

Refrigerant R-410A

Refrigerants may contain substances that are toxic and hazardous to the environment, or which release hazardous decomposition products. These must not be released into the environment. Commission a specialist disposal company to dispose of hazardous substances and materials.

Coolant, glycol

Coolants may contain substances that are toxic and pose a hazard to the environment. They must not be released into the environment. Commission a specialist disposal company to dispose of hazardous substances and materials.

Batteries

Battery components are toxic and pose a hazard to the environment. Batteries must not be disposed of with domestic waste. Batteries must only be disposed of by locally approved specialist companies.

Lubricants

Lubricants such as greases and oils contain toxic substances. They must not be released into the environment. Commission a specialist disposal company to dispose of hazardous substances and materials.

Compressor oil

Compressor oil must not enter sewerage systems or bodies of water. Commission a specialist disposal company to dispose of hazardous substances and materials.

8 Glossary

Exhaust air – EHA

Exhaust air is the air flow that flows outdoors from the inside.

Extract air – ETA

Extract air is the air flow leaving the treated room.

HVAC technician

Certified HVAC technicians have sufficient professional training in their special field, enabling them to carry out their assigned duties at the level of responsibility allocated to them and in compliance with the relevant guidelines, safety regulations and instructions. Certified HVAC technicians have in-depth knowledge and skills related to HVAC systems and air distribution technology.

Indoor air – IDA

Indoor air is the air in the treated room or area.

Outdoor air – ODA

Outdoor air (ODA) is the untreated air that flows into the AHU from outside or into an opening.

Qualified electrician

Certified and skilled electricians are able to execute work on electrical systems in compliance with the relevant standards and regulations. They understand any potential hazards related to their work, and independently recognise and avoid any risks involved.

Qualified refrigeration technician

Qualified refrigeration technicians have been trained and certified in the field of refrigeration engineering, and they know the relevant standards and guidelines. Certified and skilled refrigeration technicians are able to execute work on refrigeration systems, understand any potential hazards related to the work, and independently recognise and avoid any risks involved.

Recirculated air – RCA

Recirculated air is extract air that is returned to the air handling unit and recycled as supply air.

Secondary air – SEC

Secondary air is the air flow that is taken from a room and returned to the same room after treatment.

Supply air – SUP

Airflow entering the room or air entering the unit after being treated in the AHU.

Transfer air – TRA

Room air that flows from the treated room into another treated area is referred to as transfer air.

9 Index

A

Accident.....	10
Adjusting multileaf dampers.....	61
AHU casing units	
Applying sealing tape.....	37
Assembling AHU casing units for outdoor installation.....	37
Assembling the roof segments.....	37
Assembly.....	26
Cover strips for the intermediate frame, fixing.....	39
Installing ducts.....	40
Installing the noise insulating connector.....	28
Joining with screws/bolts.....	26
Screw-fixing stacked units.....	26
Setup.....	25
Stacked installation.....	26
AHU components	
Seals, checking.....	25
Air handling unit	
Commissioning.....	54
Electrical connection.....	52
Installing accessories.....	40
Aligning droplet eliminator.....	63
Applying sealing tape.....	37
Assembling the roof segments.....	37 , 38
Assembly	
Accessories.....	40
AHU casing units for outdoor installation.....	37
Assembling AHU casing units.....	26
Ducts.....	40
Installing AHU casing units on top of each other.....	26
Intermediate frame, fixing the cover strips.....	39
Plate heat exchanger.....	30
Roof segments.....	37
Weather hood.....	38
Attaching the weather hood.....	38
C	
Calculate height of drain trap.....	42
Claims for material defects.....	3
Commissioning the centrifugal fan.....	56
Commissioning the humidifier.....	63
Condensate drain.....	44
Connecting a drain trap.....	44
Cooling coil	
Commissioning.....	58
Installing.....	45
Copyright.....	3

D

Defect liability guarantee.....	3
Delivery of the air handling unit.....	11

E

Electric air heater	
Commissioning.....	59
Electrical connection.....	52
Electric current.....	9
Environmental protection	
Chemicals.....	67
Electrical and electronic components.....	66

F

Fan.....	9
Filters, inserting.....	58
Fire.....	10
First aid.....	10

H

Hazardous area.....	10
Heating coil	
Commissioning.....	58
Installing.....	45
hydraulic unit.....	48

I

Improper transport equipment.....	12
Initial commissioning.....	54
Adjusting inspection access doors.....	55
Centrifugal fan.....	56
Electric air heater.....	59
Filters.....	58
Heating coil/cooling coil.....	58
Humidifier.....	63
Multileaf dampers.....	61
Plate heat exchanger.....	62
Rotary heat exchanger.....	62
Run around coil system.....	59 , 60
Sound attenuator.....	61
Switching on.....	64
Inspection access doors	
Leakage.....	55
Installation	
Calculate height of drain trap.....	42
Condensate drain.....	44
Connecting a drain trap.....	44
Connecting the heating coil/cooling coil.....	45
Connection to the central BMS.....	52
Network connection.....	53
Run around coil system.....	47
Steam heat exchanger, connecting.....	46

Installation location, requirements			
Installation room.....	23		
Installing			
Noise insulating connector.....	28		
Installing accessories.....	40		
Installing ducts.....	40		
Intermediate frame, fixing the cover strips.....	39		
L			
Lashing points.....	14		
Leakage			
Inspection access doors.....	55		
Limitation of liability.....	3		
N			
Noise.....	9		
Noise insulation.....	24		
O			
Other applicable documentation.....	3		
P			
Packages			
Storage.....	19		
Transport.....	13, 14, 17		
Unpacking.....	20		
Packaging, disposal.....	20		
Personnel.....	7		
Plate heat exchanger.....	62		
Assembly.....	30		
Q			
Qualification.....	7		
R			
Removal and disposal.....	66		
Requirements			
Assembly.....	26		
Initial commissioning.....	54		
Installation.....	41		
Starting.....	63		
Requirements for the installation location			
Foundation of the installation room.....	23		
Foundation of the outdoor installation area.....	24		
Installation room.....	23		
Residual risks.....	8		
Rotary heat exchanger.....	62		
Setting up the drive equipment.....	62		
Run around coil system			
Commissioning.....	59, 60		
Connection.....	47		
S			
Service.....	3		
Setup and assembly.....	22		
Sound attenuator.....	61		
Specific hazards.....	8		
Starting.....	63		
Steam heat exchanger			
Installing.....	46		
Storage.....	19		
Suspended loads.....	8		
Symbols.....	4		
On the packaging.....	11		
System owner.....	7		
System owner's obligations.....	7		
T			
Technical support.....	3		
Transport			
Crane and eye nuts.....	16		
Crane and lifting eyes.....	15		
Crane and transport tubes.....	17		
Delivery.....	11		
Delivery check.....	11		
Forklift or pallet truck.....	13		
Transport damage.....	11		
Transport locks.....	14		
Transport protection.....	20		
Transport straps.....	14, 20		
Transport tubes.....	20		
U			
Unpacking.....	20		
V			
Vibration, preventing.....	24		
W			
Wiring.....	50		
X			
X-CUBE.....	6		
X-CUBE components.....	6		



TROX SE
Heinrich-Trox-Platz
47506 Neukirchen-Vluyn
Germany

+49 (0) 2845 202-0
+49 (0) 2845 202-265
E-Mail: trox-de@troxgroup.com
www.troxtechnik.com

© TROX SE 2016